

**125 EXE, SUPER MOTO**

**KTM**  
SPORTMOTORCYCLES

**ERSATZTEILKATALOG**

FAHRGESTELL

**SPARE PARTS MANUAL**

CHASSIS

**2000**





TELEGABEL WP USD40  
FRONT FORK WP USD40

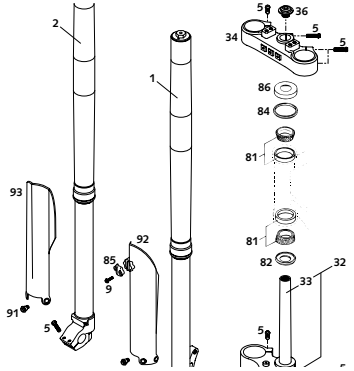

SEITE  
Page  
**4**

GABELBEINE WP USD40  
FORK LEG WP USD40

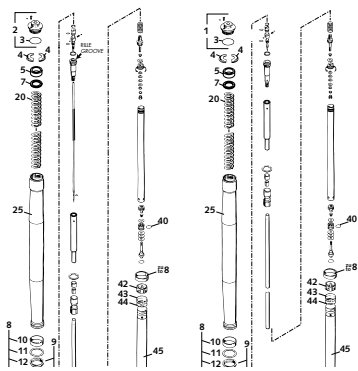

SEITE  
Page  
**5**

LENKER, ARMATUREN  
HANDLEBAR, CONTROLS

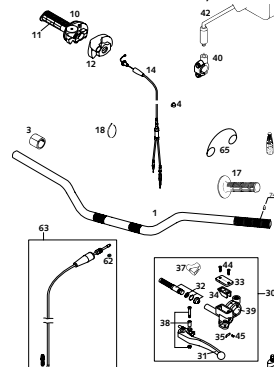

SEITE  
Page  
**6**

HANDBREMSZYLINDER  
HAND BRAKE CYLINDER

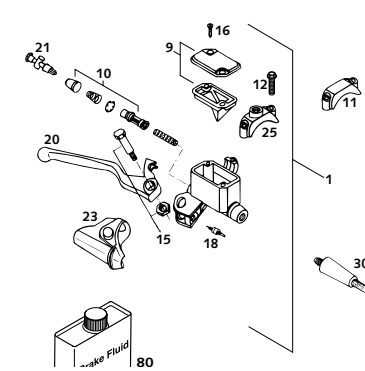

SEITE  
Page  
**7**

RAHMEN, AUSLEGER  
FRAME, SUB FRAME

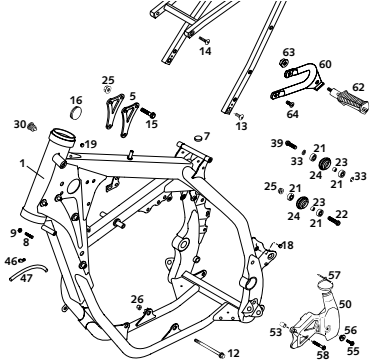

SEITE  
Page  
**8**

MITTELSTÄNDER  
CENTER STAND

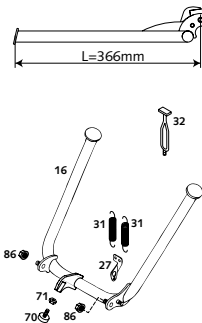

SEITE  
Page  
**10**

SCHWINGARM, KETTENSCHUTZ  
SWINGARM, CHAIN GUARD

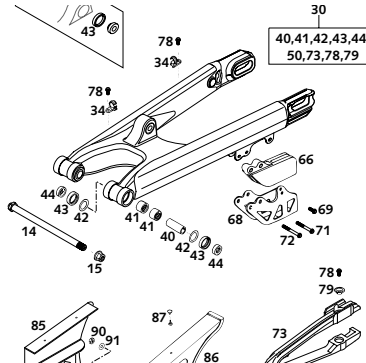

SEITE  
Page  
**11**

FUSSBREMSBETÄTIGUNG  
REAR BRAKE CONTROL

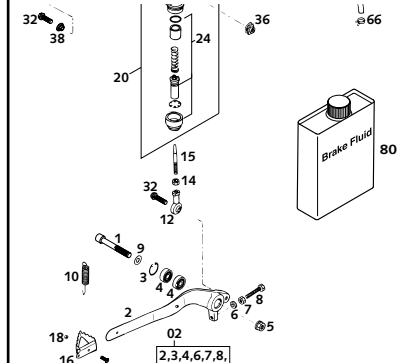

SEITE  
Page  
**12**

FEDERBEIN WP PDS  
SHOCK ABSORBER WP PDS

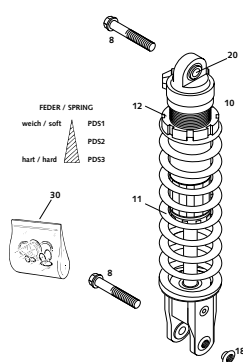

SEITE  
Page  
**13**

AUSPUFF  
EXHAUST PIPE

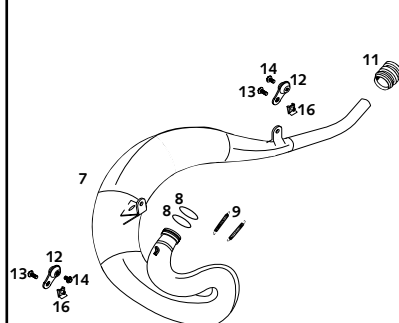

SEITE  
Page  
**14**

ENDDÄMPFER  
EXHAUST SILENCER

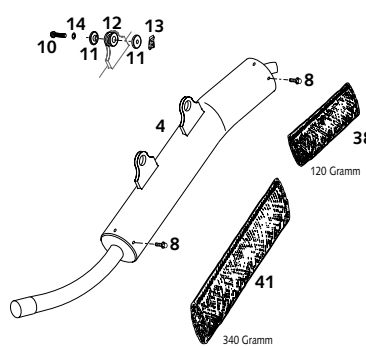

SEITE  
Page  
**15**

LUFTFILTERKASTEN  
AIR FILTER BOX

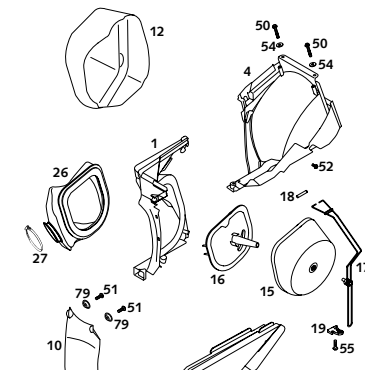

SEITE  
Page  
**16**

TANK, SITZBANK, VERKLEIDUNG  
TANK, SEAT, COVER

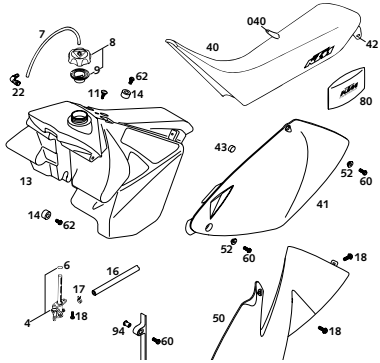

SEITE  
Page  
**17**

MASKE, KOTFLÜGEL  
MASK, FENDER

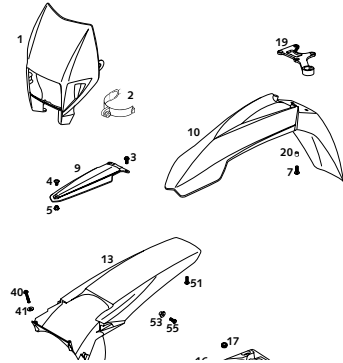

SEITE  
Page  
**18**

DEKOR  
DECAL

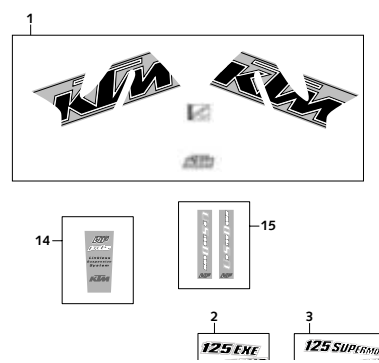

SEITE  
Page  
**19**

VORDERRAD EXE  
FRONT WHEEL EXE

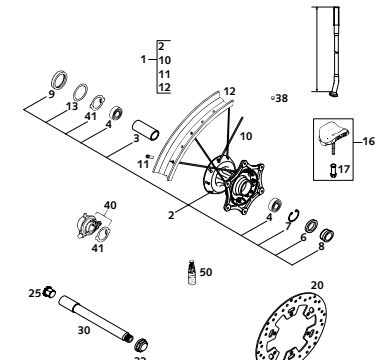

SEITE  
Page  
**20**

VORDERRAD SUPER MOTO  
FRONT WHEEL SUPER MOTO

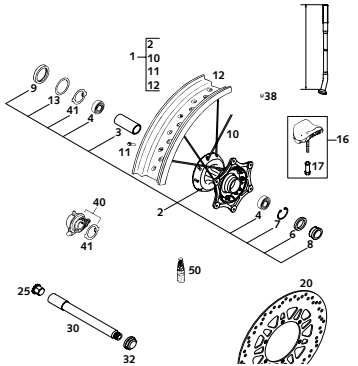

SEITE  
Page  
**21**

BREMSZANGE VORNE EXE  
BRAKE CALIPER FRONT EXE

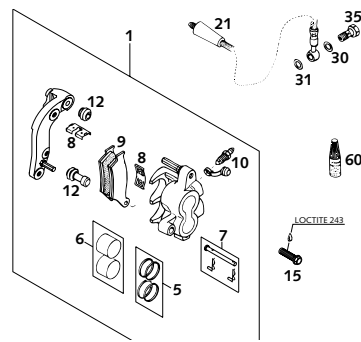

SEITE  
Page  
**22**

BREMSZANGE VORNE SUPER MOTO  
BRAKE CALIPER FRONT SUPER MOTO

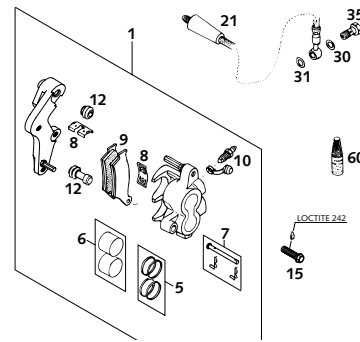

SEITE  
Page  
**23**

HINTERRAD EXE  
REAR WHEEL EXE

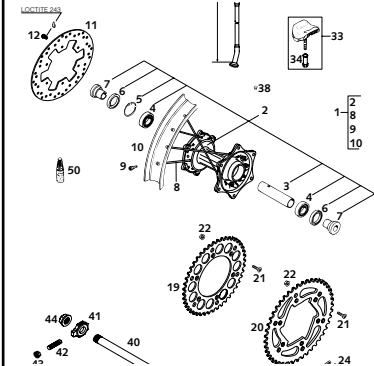

SEITE  
Page  
**24**

HINTERRAD SUPER MOTO  
REAR WHEEL SUPER MOTO

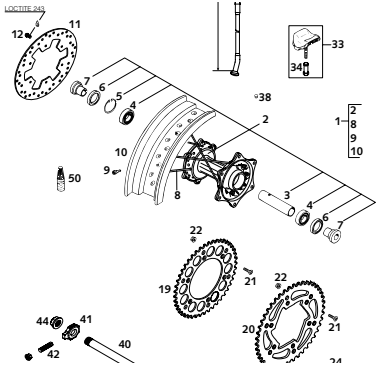

SEITE  
Page  
**25**

BREMSZANGE HINTEN  
BRAKE CALIPER REAR

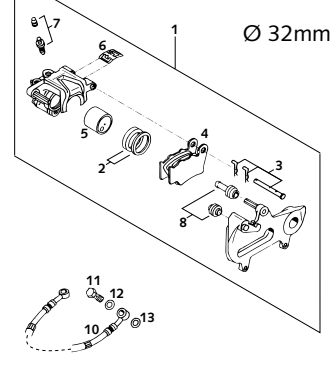

SEITE  
Page  
**26**

SCHEINWERFER, RÜCKLICHT, BLINKER  
HEAD LIGHT, REAR LIGHT, FLASHER

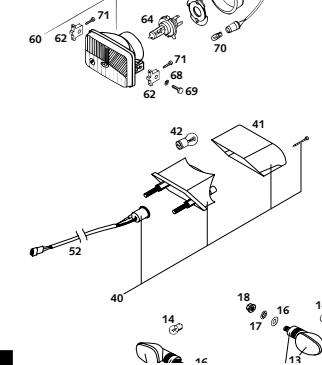

SEITE  
Page  
**27**

TACHOANLAGE  
SPEEDOMETER

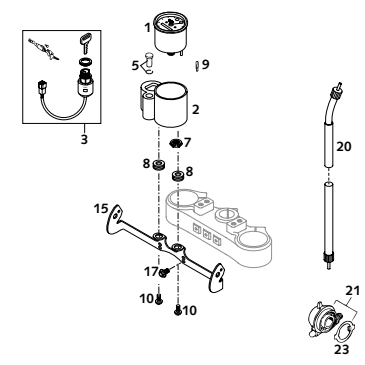

SEITE  
Page  
**28**



FIG	TEILNR/PARTNR	BEZEICHNUNG	DESCRIPTION	QTY
1*	0618.T777LS	GABELBEIN LI. WP 125 EXE 2000	FORK LEG L/S WP 125 EXE 2000	1
2*	0618.T777RS	GABELBEIN RE. WP 125 EXE 2000	FORK LEG R/S WP 125 EXE 2000	1
5	0015 080303	SK.BUNDSCHRAUBE M 8X30 SW=10	HH COLLAR SCREW M 8X30 WS=10	17
6	0912 100250	ISK.SCHR.DIN0912-M10X25 SICH.	AH SCREW DIN0912-M10X25 W.LOCK	2
9	0017 060203	SONDERSCHRAUBE T60 6X20	SPECIAL SCREW T60 6X20	2
32	590.01.132.020	GABELBR.UNT.KPL.X=20MM/D=57MM	BOT.TRIPLE CLAMP X=20MM/D=57MM	1
33	501.01.033.100	GABELSCHAFTTROHR L=244 '91	FORK TUBE L=244 '91	1
34	590.01.034.020	GABELBRÜCKE OBEN X=20MM/D=54MM	TOP TRIPLE CLAMP X=20MM/D=54MM	1
36	503.01.036.000	STEUERKOPFSCHR. M20X1,5 SW=27	STEER.HEAD SCREW M20X1,5 SW=27	1
38	590.01.038.000	LENKERKLEMMBRÜCKE 22MM 2T 2000	HANDLEBAR CLAMP 22MM 2T 2000	2
39	590.01.039.000	LENKERAUFNAHME 22MM 2T 2000	HANDLEBAR SUPPORT 22M 2T 2000	1
81	542.01.081.000	KEGELROLLENLAGER STEUERKOPF	TAPERED ROLLER BEARING	2
82	546.01.084.100	O-RINGTRÄGER M. DICHTLIPPE '91	O-RING SUPPORT W. SEALING LIP	1
84	546.01.184.000	STEUERKOPFABDICHTUNG OBEN	STEERING HEAD GASKET TOP	1
85	590.01.085.000	KLEMME F.BREMSSCHLAUCH SC '99	CLAMP F. BRAKE HOSE SC '99	1
86	542.01.086.000	SCHUTZRING	STEERING HEAD COVER	1
91	590.01.092.050	SONDERSCHRAUBE M6X12,5 SW=8	SPECIAL SCREW M6X12,5 SW=8	6
92	590.01.092.000	GABELSCHUTZ LINKS SILBER SC '99	FORK PROTEC. L/S SILVER SC '99	1
93	590.01.093.000	GABELSCHUTZ RE. SILBER SC '99	FORK PROTEC. R/S SILVER SC '99	1

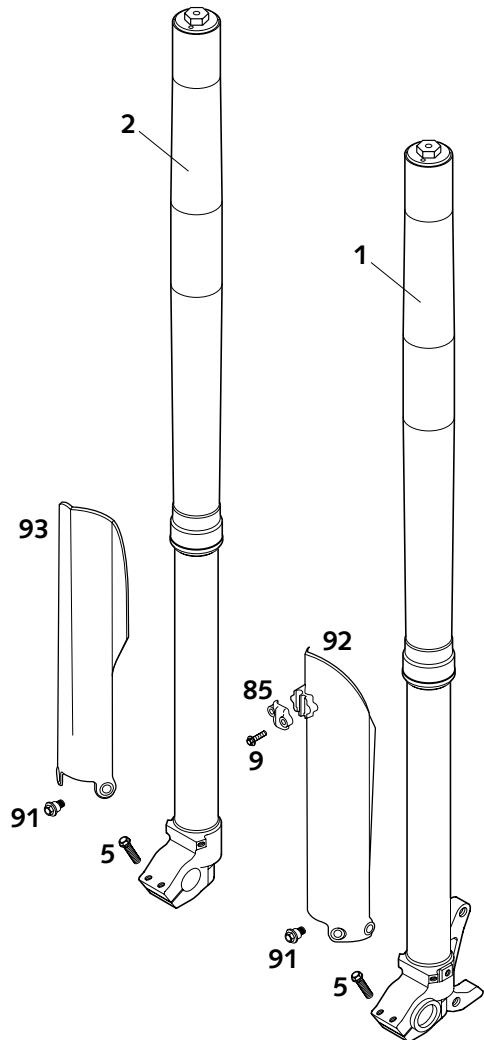
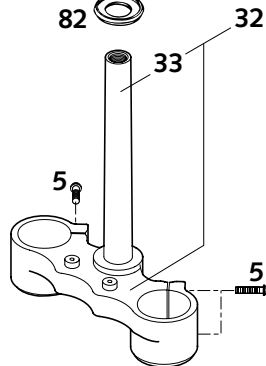
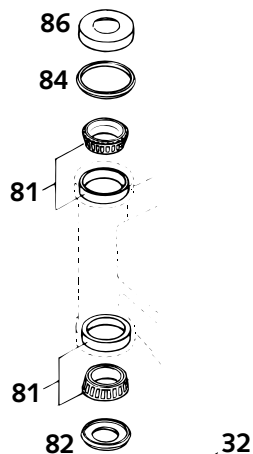
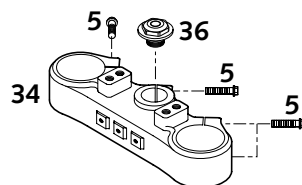
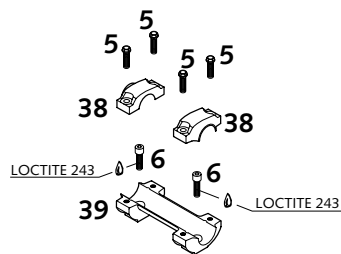
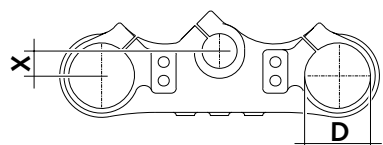

**ZUGSTUFE RECHTS**  
REBOUND DAMPING RIGHT

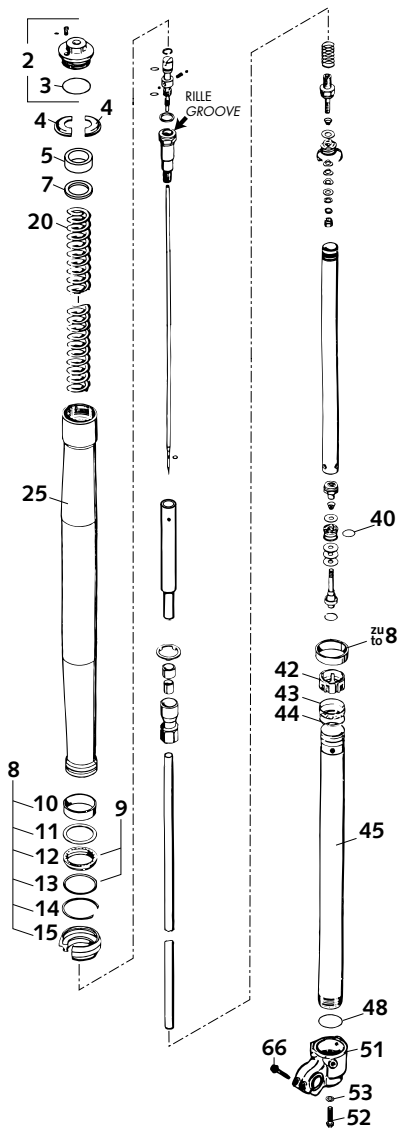

**DRUCKSTUFE LINKS**  
COMPRESS DAMPING LEFT

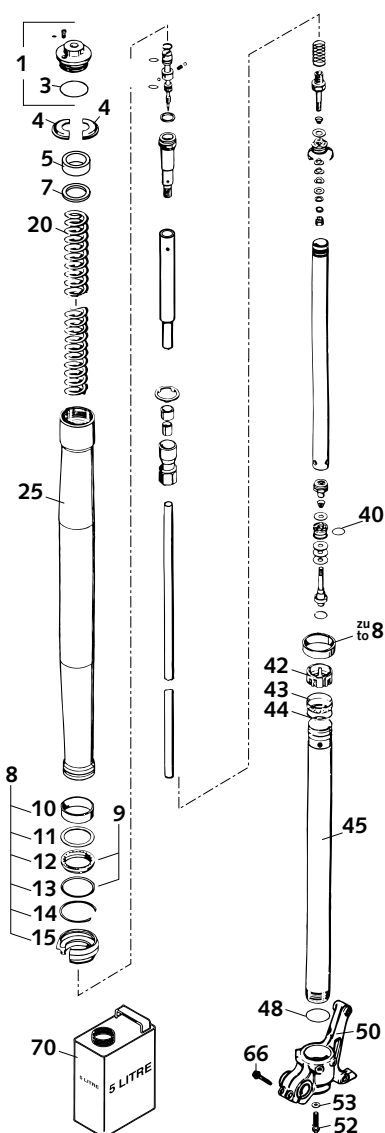

FIG	TEILNR/PARTNR	BEZEICHNUNG	DESCRIPTION	QTY
1	583.01.008.600	VERSCHLUßKAPPE KPL. LI. „COM“	SCREW CAP CPL. L/S „COM“	1
2	583.01.009.600	VERSCHLUßKAPPE KPL. RE. „REB“	SCREW CAP CPL. R/S „REB“	1
3	0770 430030	O-RING 43,00X3,00	O-RING 43,00X3,00	2
4	545.01.050.000	HALBMOND KEIL	KEY HALF	4
5	564.01.022.000	+ VORSPANNBÜCHSE 25X34X5	PRELOAD BUSHING 25X34X5	X
5	564.01.022.100	+ VORSPANNBÜCHSE 25X34X10	PRELOAD BUSHING 25X34X10	X
5	564.01.022.200	+ VORSPANNBÜCHSE 25X34X2,5	PRELOAD BUSHING 25X34X2,5	X
7	545.01.019.000	SCHEIBE 24,5X34X2	WASHER 24,5X34X2	2
8	502.01.668.244	+ REP.SATZ WELLENDICHTR.+BÜ.	REPAIR KIT SEAL S.RINGS+BUSH.	2
9	502.01.669.244	+ REP.SATZ WELLENDICHTRINGE	REPAIR KIT SEAL SHAFT RINGS	2
10	575.01.026.000	+ FÜHRUNGSBÜCHSE 40X44X20-10	GUIDE BUSHING 40 X 44 X 20-10	2
11	564.01.027.000	+ RING 42X49,2X1,5	RING 42X49,2X1,5	2
12	580.01.805.000	+ WELLENDICHTRING 40X49,5X9LF	SHAFT SEAL RING 40X49,5X9LF	2
13	564.01.127.000	+ RING 49,5X45X1	RING 49,5X45X1	2
14	564.01.029.000	+ SEEGER-SPRENGRING SB50	SEEGER LOCK RING SB50	2
15	564.01.025.100	+ STAUBMANSCHETTE D40 '91	DUST BELLOWS D40 '91	2
20*	9601.00515	FEDER 4,2 N/MM SET	SPRING 4,2 N/MM SET	1
25	583.01.004.900	AUSSENROHR L=550MM '97	OUTER TUBE L=550MM '97	2
40	0770 020160	O-RING 15,60X1,78	O-RING 15,60X1,78	2
42	545.01.077.000	SPANNBÜCHSE	BUSHING	2
43	545.01.045.000	+ LAGERRING 42,8X13	BEARING RING 42,8X13	2
44	545.01.046.000	RING 39X42X1	RING 39X42X1	2
45	583.01.203.000	INNENROHR L=520MM DUKE'94	INNER TUBE L=520MM DUKE'94	2
48	0770 380020	O-RING 38,00X2,00	O-RING 38,00X2,00	2
50*	4054.1389	GABELFAUST LINKS 125 EXE 2000	AXLE CLAMP L/S 125 EXE 2000	1
51*	4054.1388	GABELFAUST RECHTS 125 EXE 2000	AXLE CLAMP R/S 125 EXE 2000	1
52	545.01.082.100	SK.BUNDSCHRAUBE M 8X30	HH COLLAR SCREW M 8X30	2
53	580.38.032.100	CU-DICHTRING 8 X 12 X 2	SEAL RING 8 X 12 X 2	2
66*	5060.0061	+ SK BUNDSCHRAUBE M 8X30	HH COLLAR SCREW M 8X30	4
70	4054.0882	+ GABELÖL REZ 71 SAE 5	FORKOIL REZ 71 SAE 5	1

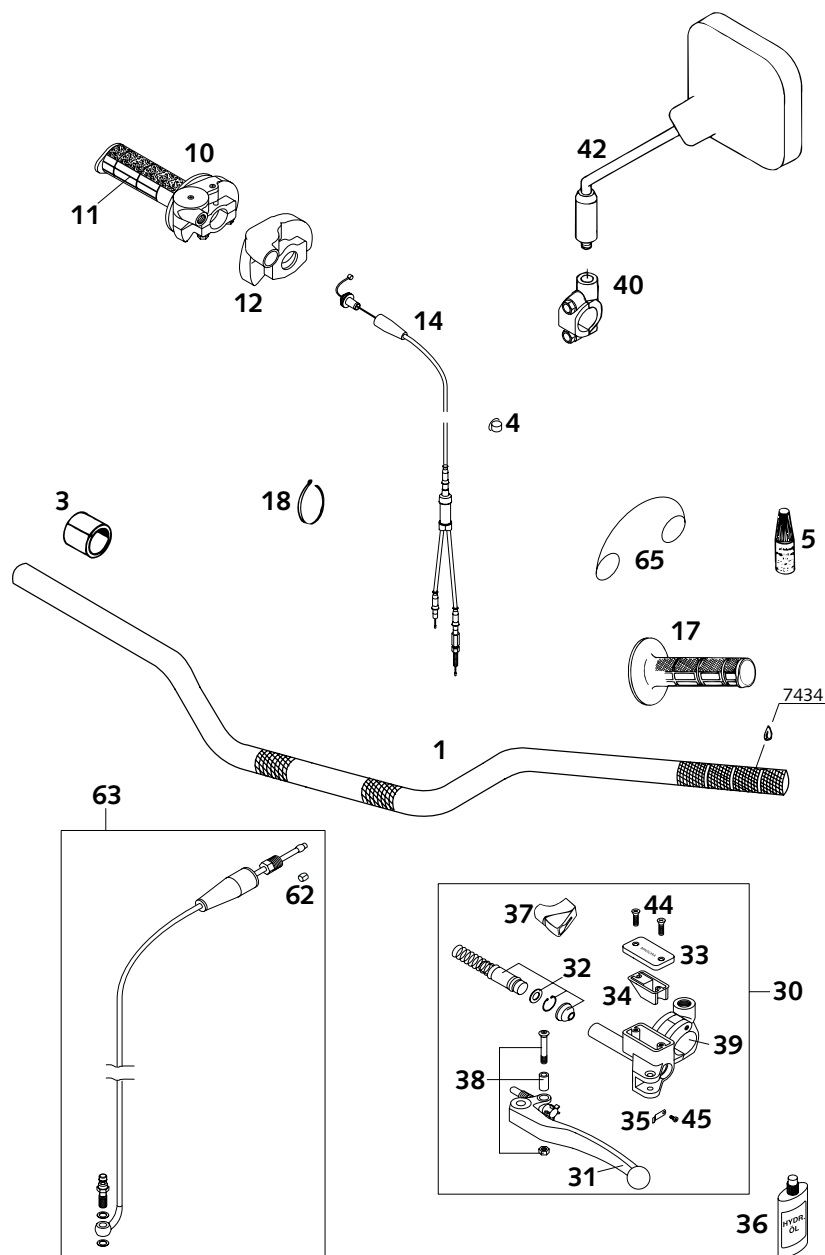

FIG	TEILNR/PARTNR	BEZEICHNUNG	DESCRIPTION	QTY
1	583.02.001.400	ALU-LENKER SILBER „4T“ '97	ALU-HANDLEBAR SILVER „4T“ '97	1
3	502.02.010.000	DISTANZBÜCHSE 22X28X22 PVC	SPACER BUSHING 22X28X22PVC	X
4	570.13.072.000	KABELHALTER 12MM 0210	WIRING HOLDER 12MM 0210	1
5	6 899 791	KLEBER CYANACRYLAT 7434	GLUE CYANACRYLAT 7434	1
10	503.02.010.000	GASDREHGRIF KPL. OHNE SEIL'97	THROTTLE TWIST GRIP CPL. '97	1
11	502.02.003.000	DREHGRIFÜBERZUG DOMINO SCHW.	TWIST GRIP COVER DOMINO BLACK	1
12	503.02.020.000	SCHUTZKAPPE DOMINO '97	PROTECTION COVER '97	1
14	523.02.091.000	GASSEIL M.VERTEILER KPL.SGP'99	THROT.CABLE W.DISTRIBUT.SGP'99	1
17	502.02.052.000	FESTGRIF DOMINO SCHWARZ '95	FIXED GRIP DOMINO BLACK '95	1
18	440.11.276.200	KABELBAND 200 X 5MM T50 R/SF	CABLE TIE 200 X 5MM T50 R/SF	1
30	503.02.030.000	GEBERZYLINDER KPL. 125-200 '98	MASTER CYL. CLUTCH 125-200'98	1
31	503.02.031.100	KUPP.HEBEL KURZ KPL. 2T 2000	CLU.LEVER SHORT CPL. 2T 2000	1
31	503.02.031.000	KUPPLUNGSHABEL KPL. 125-200'98	CLUTCH LEVER CPL. 125-200 '98	X
32	503.02.032.000	REP.SATZ KOLBEN KUP. HYDR. '98	REP.SATZ PISTON CLUT.HYDR. '98	1
33	503.02.033.000	DECKEL FÜR HYDR. KUPPLUNG '98	COVER FOR HYDR. CLUTCH '98	1
34	503.02.034.000	GUMMIBALG FÜR RESERVOIR '98	RUBBER FOR RESERVOIR '98	1
35	503.02.035.000	BLATTFEDER FÜR HEBEL '98	SPRING PLATE FOR LEVER '98	1
36	503.02.036.000	ÖL FÜR HYD.KUPPLUNG 50ML	OIL FOR HYD.CLUTCH 50ML	1
37	503.02.037.000	SCHUTZKAPPE FÜR HEBELGELENK'98	PROTECT.CAP FOR LEVER PERCH'98	1
38	503.02.038.000	HEBELSCHRAUBE KPL. 125-200 '98	LEVER SCREW CPL. 125-200 '98	1
39	590.02.044.000	KLEMMSCH.SPIEGEL M.SPANNSTIFT	CLAMP MIRROR WITH PIN M10X1,25	1
40	503.12.042.000	SPIEGELHALTERUNG LI. M10X1,25	MIRROR CLAMP L/S M10X1,25	X
42	580.12.040.000	RÜCKBLICKSPIEGEL LINKS	REAR MIRROR L/S	1
—	580.12.140.000	RÜCKBLICKSPIEGEL RECHTS	REAR MIRROR R/S	X
44	0965 040123	SENKSCHRAUBE DIN0965-M 4X12	FLAT HEAD SCREW DIN0965-M 4X12	2
45	0984 030063	ZYL.SCHRAUBE DIN7984-M 3X 6	AH SCREW DIN7984-M 3X 6	1
62	503.32.063.050	SCHNEIDRING FÜR HYDR.LEITUNG	SELF CUTTING RING HYDR.PIPE	X
63	503.32.063.000	LEITUNGSKIT FÜR HYDR.KUPPL.'98	PIPE KIT FOR HYDR. CLUTCH '98	1
65	502.02.052.050	BINDEDRAHT F. FESTGRIF DOMINO	WIRE FOR FIXED GRIP DOMINO	X



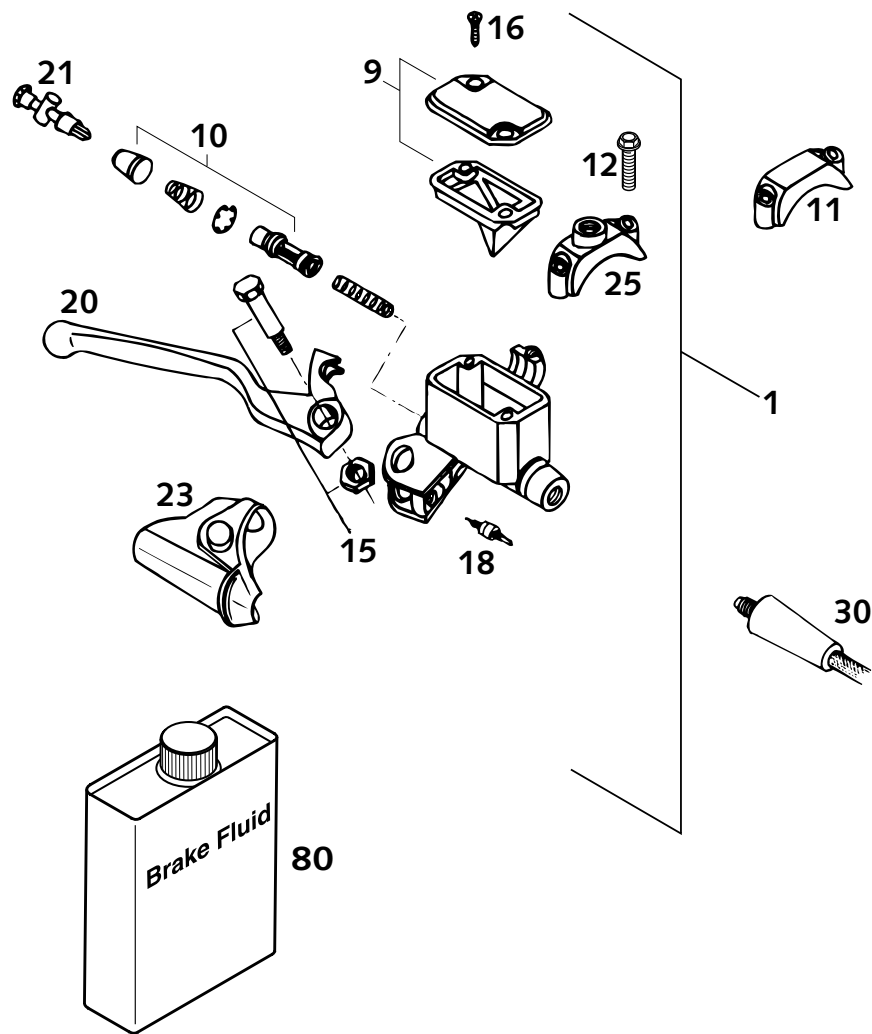

FIG	TEILNR/PARTNR	BEZEICHNUNG	DESCRIPTION	QTY
1	584.13.001.000	HANDBREMSZYLINDER SCHWARZ 2000	HAND BRAKE CYLINDER BLACK 2000	1
9	502.13.012.000	DECKEL KPL.	COVER CPL.	1
10	502.13.050.000	REPARATUR-SATZ KOLBEN 11MM	REPAIR KIT PISTON 11MM	1
11	544.13.011.000	SCHELLE BREMBO	CLAMP BREMBO	X
12	0015 060253	SK.BUNDSCHRAUBE M 6X25 SW=8	HH COLLAR SCREW M 6X25 WS=8	2
15	502.13.015.000	HEBELSCHRAUBE KPL.	LEVER SCREW CPL.	1
16	0965 050163	SENKSCBRAUBE DIN0965-M 5X16	FLAT HEAD SCREW DIN0965-M 5X16	2
18	510.11.050.000	BREMSLICHTSCHALTER VORNE	FRONT BRAKE LIGHT SWITCH	1
20	502.13.020.000	HANDBREMSHEBEL LOSE BREMBO'94	HAND BRAKE LEVER LOOSE BREM'94	1
21	502.13.021.000	STELLSCHRAUBE KPL.	ADJUSTING SCREW CPL.	1
23	502.13.023.000	SCHUTZKAPPE BREMBO'94	PROTECTION CAP BREMBO'94	1
25	580.12.040.150	KLEMMSCHELLE FÜR SPIEGEL '94	CLAMP FOR MIRROR '94	1
30*	512.13.011.000	BREMSSCHL. VO. 1210MM EXE 2000	BRAKEHOSE FRONT 1210MM EXE2000	1
80	306054	BREMSFLÜSSIGKEIT DOT 5.1	BRAKE FLUID DOT 5.1	1

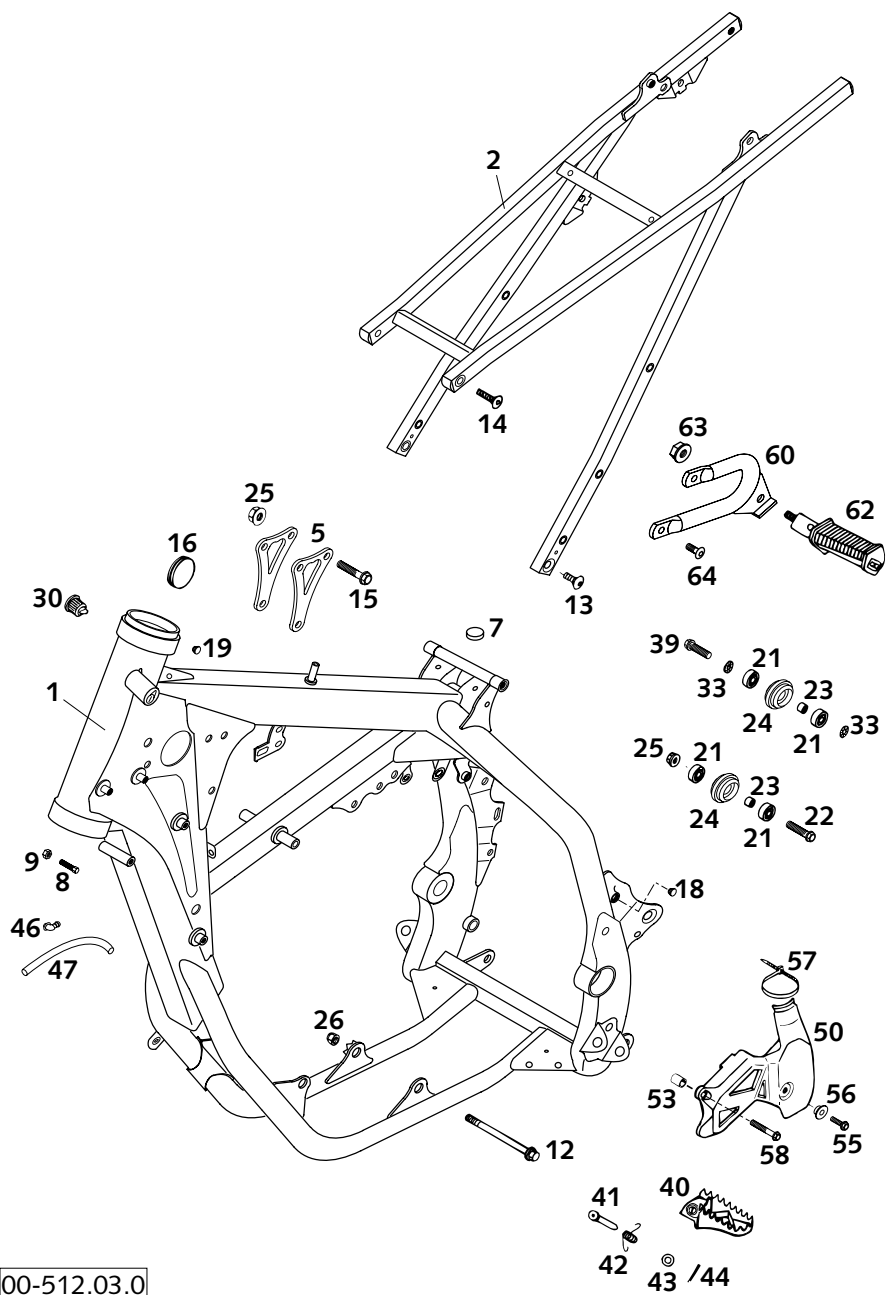
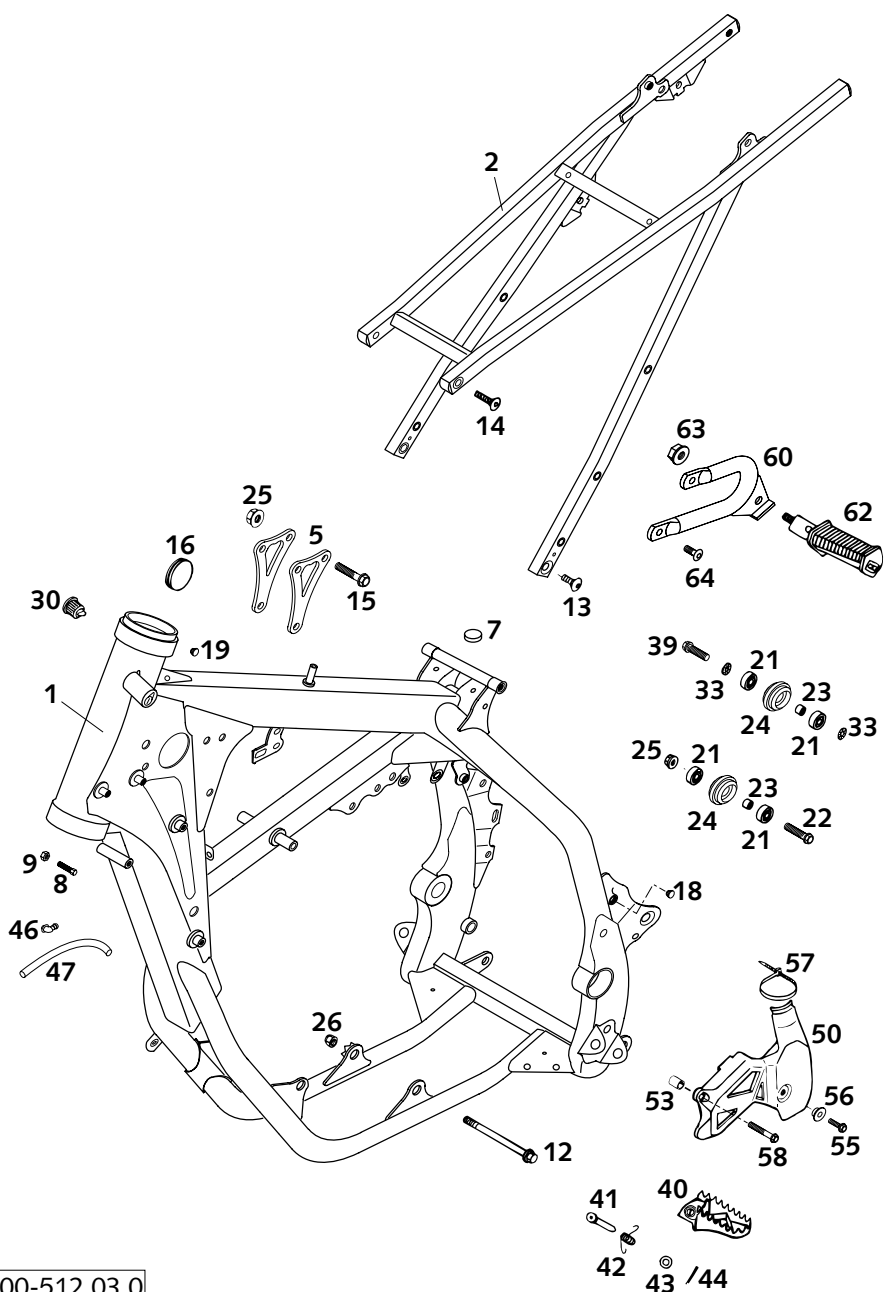

FIG	TEILNR/PARTNR	BEZEICHNUNG	DESCRIPTION	QTY
1	503.03.001.300	RAHMEN 125/200 EXC EU/AU 2000 MIT SCHLOSSKÖRPER, SILBER	FRAME 125/200 EXC EU/AUS 2000 WITH LOCK BODY, SILVER	1
2*	512.03.002.044	AUSLEGER 125 EXE KPL. ALU 2000	SUB FRAME 125 EXE CPL.ALU 2000	1
5	503.03.013.000	MOTORSTREBE 125 '98	REINFORCING BRACKET 125 '98	2
7	503.07.020.000	GUMMIPUFFER FÜR TANK '98	RUBBER BUFFER FOR TANK '98	2
8	590.01.037.000	ANSCHLAGSCHRAUBE M8X26 SW=10	SPECIAL SCREW M8X26 WS=10	2
9	0934 080003	SK.MUTTER DIN0934-M 8	HEXAGON NUT DIN0934-M 8	2
12	546.03.013.000	MOTORTRAGSCHR. M10X105-10.9	ENGINE BRAC.SCREW M10X105-10.9	2
13	546.10.052.000	KETTENRADSCHRAUBE-ISK M 8X20	SPROCKET SCREW-AH M 8X20	2
14	545.10.052.100	KETTENRADSCHR.-ISK M8X29 10.9	SPROCKET SCREW-AH M8X26 10.9	2
15	565.30.079.000	BUNDSCHRAUBE M8X42-10.9	SPECIAL SCREW M8X42-10.9	3
16	546.06.004.000	VERSCHLUSSKAPPE 37MM	PLUG 37 MM	2
18	544.03.135.000	VERSCHLUSSPFROPFEN SFL10	PLASTIC CAP SFL10	1
19	361.11.021.000	VERSCHLUSSPFROPFEN	PLUG	2
21	0625 006087	RILLENKUGELLAGER 608 2RS C3	GROOVED BALL BEAR. 608 2RS C3	4
22	0015 080350	SK.BUNDSCHRAUBE M 8X35 M.SICH.	HH COLLAR SCREW M 8X35 W.LOCK	1
23	740.03.021.000	BÜCHSE 8 X 12 X 6,5	BUSHING 8 X 12 X 6,5	2
24	523.03.053.000	KETTENROLLE D=30MM 125-380 '99	CHAIN ROLL D=30MM 125-380 '99	2
25	543.10.086.200	STOVER-FLANSCHMUTTER M8 10.9	SELF LOCKING NUT M8 10.9	4
26	543.10.086.100	SS.MUTTER M10 CU SW=14	SELF LOCKING NUT M10 CU WS=14	2
30	420.07.049.000	SCHUTZKAPPE	PLASTIC CAP	1
33	360.03.014.000	SCHNORR-SICHERUNGSSCHEIBE 8MM	LOCK WASHER 8MM	2
39	0015 080303	SK.BUNDSCHRAUBE M 8X30 SW=10	HH COLLAR SCREW M 8X30 WS=10	1
40	590.03.040.050	FUSSRASTE LINKS SILBER 2000	FOOT PED L/S SILVER 2000	1
—	590.03.041.050	FUSSRASTE RECHTS SILBER 2000	FOOT PED R/S SILVER 2000	1
41	546.03.044.000	BOLZEN FÜR FUSSRASTER 9,8 X 50	BOLT FOR FOOTREST 9,8 X 50	2
42	546.03.041.000	FUSSRASTENFEDER LINKS & RECHTS	FOOTREST SPRING L/S & R/S	2
43	0125 100003	UNTERLEGSCHIEBE DIN0125-A10,5	WASHER DIN0125-A10,5	2
44	0094 032253	SPLINT DIN0094-3,2X25 STAHL	PIN DIN0094-3,2X25 STEEL	2
46	503.03.089.000	WINKELSTÜCK '97	ANGEL PIECE '97	1
47	550.07.016.001	SCHLAUCH 7X10 PER METER	PVC-HOSE 7X10 PER METER	0,2
50	546.07.061.000	KETTENRITZELABDECKUNG	SPROCKET COVER	1
53	546.13.038.150	BÜCHSE 6,5X8X11	BUSHING 6,5X8X11	1
55	0015 060203	SK.BUNDSCHRAUBE M 6X20 SW=8	HH COLLAR SCREW M 6X20 WS=8	1
56	503.08.053.000	BÜCHSE FÜR SPOILER 6X11X16X7,5	BUSH FOR SPOILER 6X11X16X7,5	1

FIG	TEILNR/PARTNR	BEZEICHNUNG	DESCRIPTION	QTY
57	440.11.076.200	KABELBAND 200MM	CABLE TIE 200MM	1
58	0015 060403	SK.BUNDSCHRAUBE M 6X40 WS=8	HH COLLAR SCREW M 6X40 WS=8	1
60*	512.03.048.000	FUSSRASTENTRÄGER HINTEN LINKS	FOOTREST BRACKET REAR L/S	1
—*	512.03.049.000	FUSSRASTENTRÄGER HINTEN RECHTS	FOOTREST BRACKET REAR R/S	1
62	490.03.250.000	FUSSRASTE HINTEN LINKS KPL.	FOOTREST REAR L/S CPL.	1
—	490.03.350.000	FUSSRASTE HINTEN RECHTS KPL.	FOOTREST REAR R/S CPL.	1
63	490.09.082.000	STOVERFLANSCHMUTTER M10 FK10	SELF LOCKING NUT M10 WS=17	2
64	0107 080203	ISK.LI.SCHRAUBE DIN0107-M 8X20	AH OVAL H.SCREW DIN0170-M 8X20	4



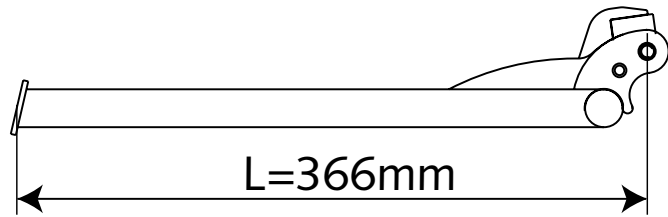
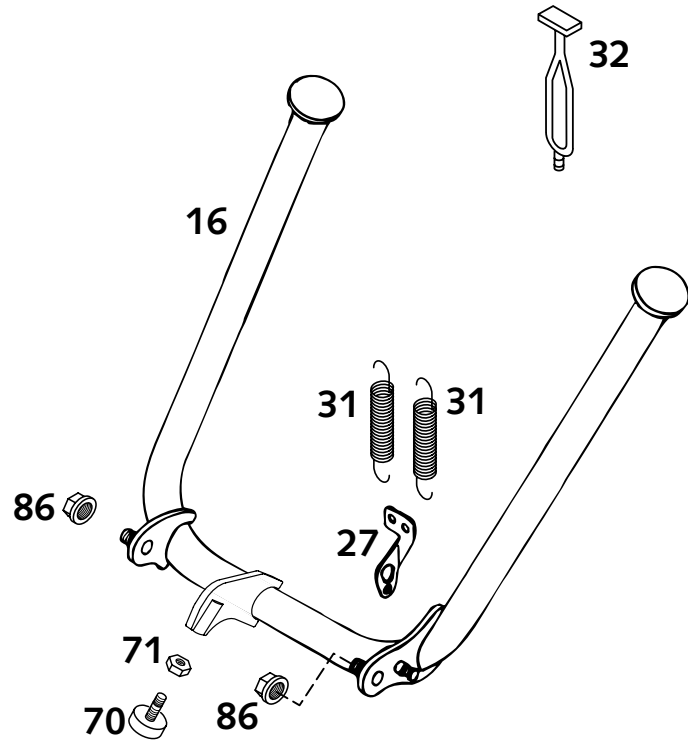

FIG	TEILNR/PARTNR	BEZEICHNUNG	DESCRIPTION	QTY
16*	512.03.016.000	MITTELSTÄNDER SILB.125EXE 2000	CENTERSTAND SILV. 125EXE 2000	1
27	546.03.027.000	FEDERLASCHE '90	SPRING HANGER '90	1
31	100.03.021.000	STÄNDERFEDER KURZ	STAND SPRING SHORT	2
32	503.03.018.000	GUMMI FÜR MITTELSTÄNDER '99	RUBBER FOR CENTER STAND '99	1
70	583.03.070.000	ANSCHLAGGUMMI M8	STOP RUBBER M8	1
71	0934 080003	SK.MUTTER DIN0934-M 8	HEXAGON NUT DIN0934-M 8	1
86	543.10.086.200	STOVER-FLANSCHMUTTER M8 10.9	SELF LOCKING NUT M8 10.9	2



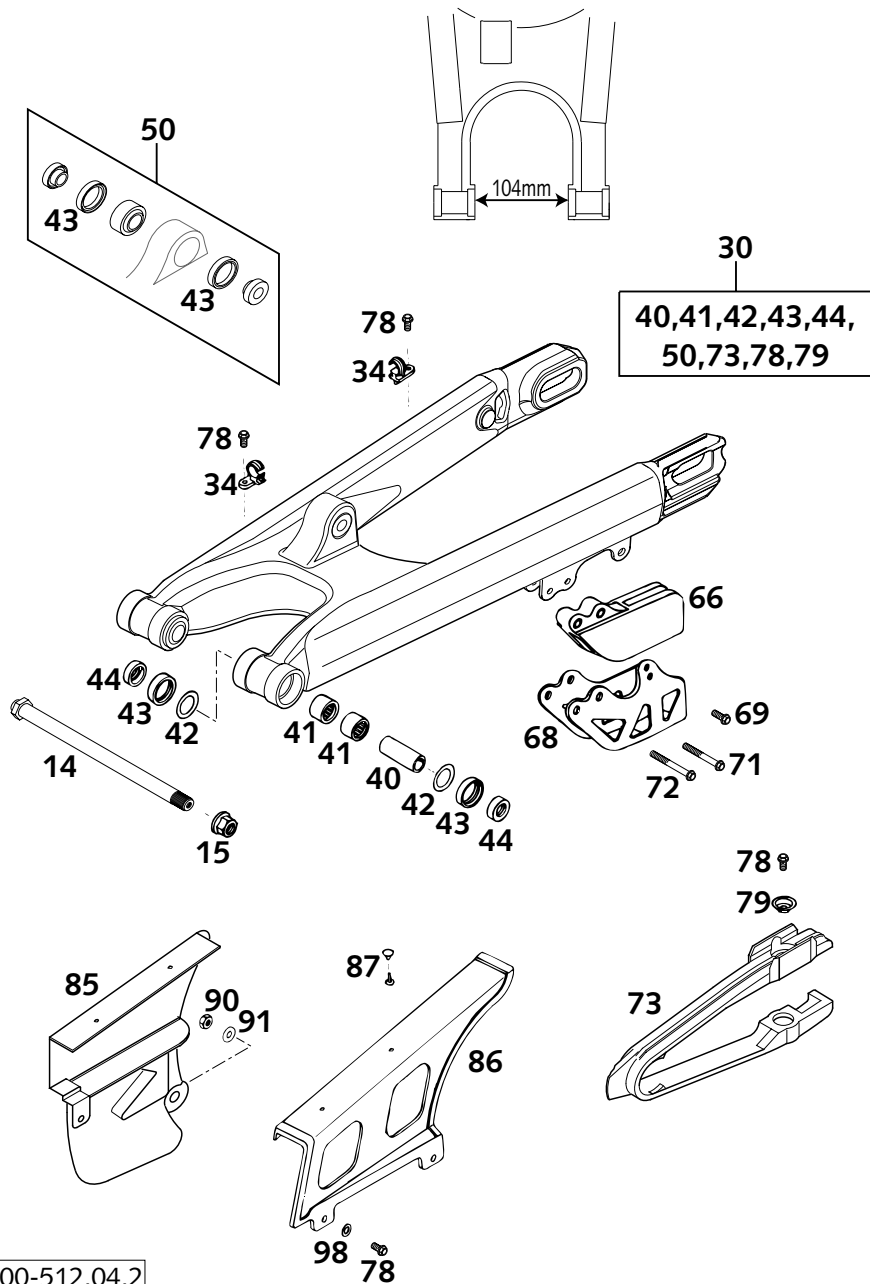

FIG	TEILNR/PARTNR	BEZEICHNUNG	DESCRIPTION	QTY
14	503.03.014.000	SCHWINGARMBOLZEN 14X252 SW=22	SWINGARM BOLT 14X252 WS=22	1
15	546.03.015.000	STOPPMUTTER M14X1,5 SW=19	SELF LOCKING NUT M14X1,5 WS=19	1
30	503.04.030.244	SCHWINGARM KPL. PDS 2T 2000	SWINGARM CPL. PDS 2T 2000	1
34	546.11.076.100	HALTESCHELLE FÜR BREMSSCHL.'96	RETAIN.CLAMP FOR BRAKE HOSE'96	2
40	546.03.081.000	LAGERHÜLSE 15 X 20 X 48	BEARING SLEEVE 15 X 20 X 48	2
41	546.03.097.000	NADELHÜLSE HK 2016	NEEDLE BUSH HK 2016	4
42	546.03.036.000	ANLAUFSCHEIBE 22,2X31,7X1	STOP DISK 22,2X31,7X1	2
43	0760 253270	WELLENDICHTRING 25X32X7	SHAFT SEAL RING 25X32X7	6
44	546.03.090.000	TASSE FÜR WELLENDICHTR.15X25X9	BUCKET F.SHAFTSEALRING 15X25X9	4
50	503.04.090.044	SCHWENKLAGER+BUCHSEN PDS '99	HEIM JOINT+BUSHES PDS '99	1
66	546.07.066.100	KETTENFÜHRUNG HINTEN '94	CHAIN GUIDE REAR '94	1
68	546.07.070.100	HALTEBLECH	RETAINING PLATE	1
69	0015 060163	SK.BUNDSCHRAUBE M 6X16 SW=8	HH COLLAR SCREW M 6X16 WS=8	1
71	0015 060503	SK.BUNDSCHRAUBE M 6X50 SW=8	HH COLLAR SCREW M 6X50 WS=8	1
72	0015 060553	SK.BUNDSCHRAUBE M 6X55 SW=8	HH COLLAR SCREW M 6X55 WS=8	1
73	503.04.066.000	KETTENGLEITSCHUTZ '97	CHAIN GUARD '97	1
78	0009 050103	GEW.FURCHSCHRAUBE M 5,0X10	SPECIAL SCREW M 5,0X10	6
79	722.10.079.000	STÜTZSCHALE	BUCKET	2
85	503.04.060.100	KETTENSCHUTZ KLEIN EXC 2000	CHAIN GUARD SMALL EXC 2000	1
86	546.07.460.000	KETTENSCHUTZ GROSS EGS	CHAIN GUARD LARGE EGS	1
87	200.12.062.055	HOHLNIET 2-TLG.	HOLLOW RIVET TWO PARTS	2
90	0985 060003	SS.MUTTER DIN0985-M 6	SELF LOCK. NUT DIN0985-M 6	1
91	0021 060003	SCHEIBE DIN9021-A 6,4	WASHER DIN9021-A 6,4	1
98	0021 050003	SCHEIBE DIN9021-A 5,3	WASHER DIN9021-A 5,3	2

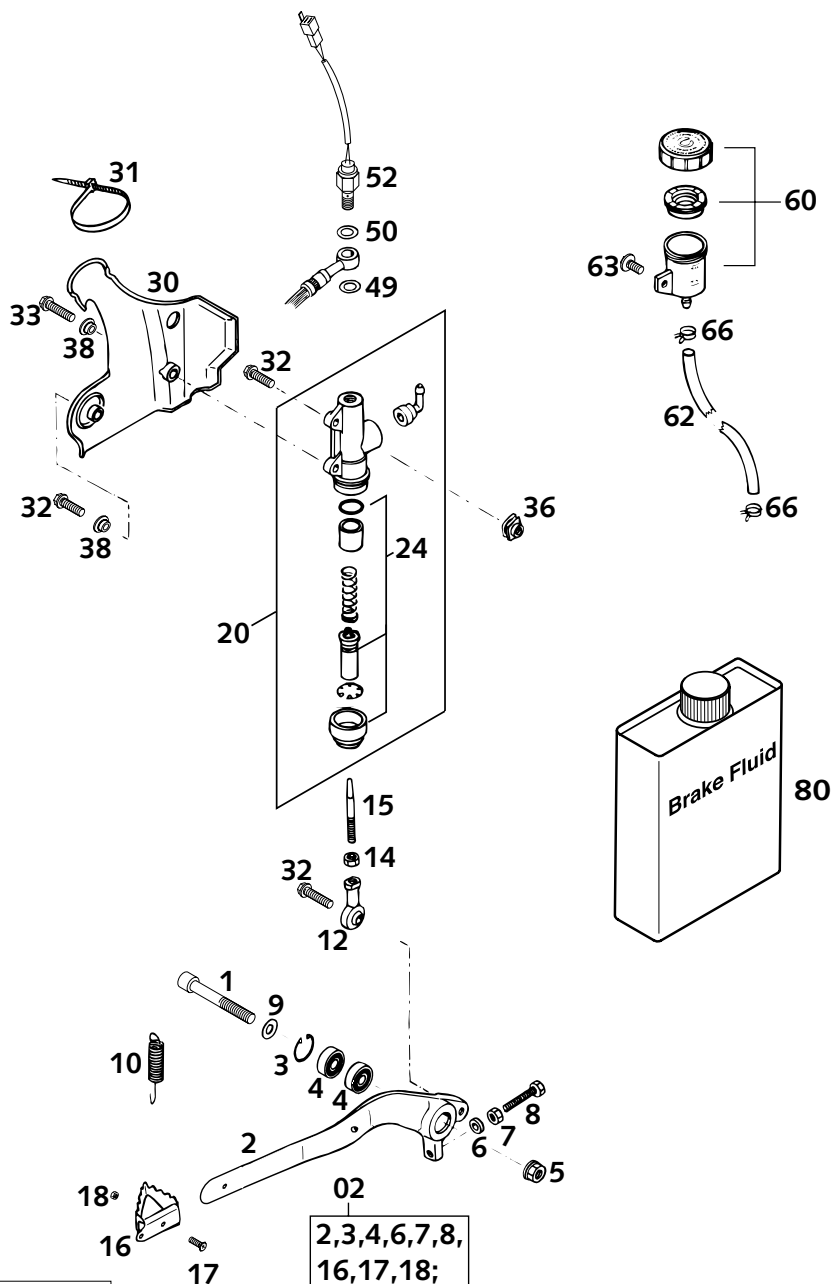

FIG	TEILNR/PARTNR	BEZEICHNUNG	DESCRIPTION	QTY
1	0912 080603	ISK.SCHRAUBE DIN0912-M 8X60	AH SCREW DIN0912-M 8X60	1
02	546.03.060.144	FUSSBREMSHEBEL KPL. 250'91	FOOT BRAKE LEVER CPL. 250'91	1
3	0472 022100	SICHERUNGSRING DIN0472-22X1	CIRCLIP DIN0472-22X1	1
4	0625 006087	RILLENKUGELLAGER 608 2RS C3	GROOVED BALL BEAR. 608 2RS C3	2
5	543.10.086.200	STOVER-FLANSCHMUTTER M8 10.9	SELF LOCKING NUT M8 10.9	1
6	120.11.016.000	SCHEIBE 6 X 12 X 3	WASHER 6 X 12 X 3	1
7	0934 060003	SK.MUTTER DIN0934-M 6	HEXAGON NUT DIN0934-M 6	1
8	0933 060353	SK.SCHRAUBE DIN0933-M 6X35	HH SCREW DIN0933-M 6X35	1
9	0125 080003	UNTERLEGSSCHEIBE DIN0125-A 8,4	WASHER DIN0125-A 8,4	1
10	546.03.062.000	RÜCKZUGFEDER FÜR BREMSHEBEL	RETURN SPRING FOR BRAKE LEVER	1
12	546.03.069.000	GELENKKOPF M6 FUßBREMSHEBEL	SWIVEL HEAD M6 FOOT BRAKELEVER	1
14	0934 060003	SK.MUTTER DIN0934-M 6	HEXAGON NUT DIN0934-M 6	1
15	546.03.068.000	DRUCKSTANGE 250 '90	PRESSURE ROD ALU 250 '90	1
16	546.03.060.150	AUFTRITT FÜR BREMSHEBEL	STEP PLATE FOR BRAKE LEVER	1
17	0966 050203	LI.SENKSCHRAUBE DIN0966-M 5X20	OVAL HEAD SCREW DIN0966-M 5X20	1
18	0985 050003	SS.MUTTER DIN0985-M 5	SELF LOCKING NUT DIN0985-M 5	1
20	503.13.060.000	FUSSBREMSZYLINDER D=12MM 2000	FOOTBRAKE CYLINDER D=12MM 2000	1
24	503.13.061.000	REP. SATZ KOLBEN 12MM 2000	REP. KIT PISTON 12MM 2000	1
30	546.13.038.100	BREMSZYL.SCHUTZ 125-380 2000	BRAKECYL.PROTECT.125-380 2000	1
31	440.11.076.200	KABELBAND 200MM	CABLE TIE 200MM	1
32	0015 060203	SK.BUNDSCHRAUBE M 6X20 SW=8	HH COLLAR SCREW M 6X20 WS=8	3
33	0015 060253	SK.BUNDSCHRAUBE M 6X25 SW=8	HH COLLAR SCREW M 6X25 WS=8	1
36	502.35.033.300	KLIPS-MUTTERNHALTER M6 KP142	SNAP-NUT HOLDER M6 KP142	2
38	503.08.053.000	BÜCHSE FÜR SPOILER 6X11X16X7,5	BUSH FOR SPOILER 6X11X16X7,5	2
49	420.13.026.000	CU-DICHTRING DIN7603-10X16X1,5	CU-SEAL RING DIN7603-10X16X1,5	1
50	420.13.226.000	CU-DICHTRING DIN7603-10X16X1	CU-SEAL RING DIN7603-10X16X1	1
52	503.11.051.100	BREMSLICHTSCHALTER HINTEN '98	BRAKE LIGHT SWITCH REAR '98	1
60	545.13.030.044	BREMSFLÜSSIGKEITSRESERVOIR '89	BRAKE FLUID RESERVOIR '89	1
62	580.07.016.101	SCHLAUCH FÜR RESERVOIR 6X1,5	HOSE FOR RESERVOIR 6X1,5	0,4
63	0014 060103	SK.BUNDSCHRAUBE M 6X10 SW=8	HH COLLAR SCREW M 6X10 WS=8	1
66	580.07.017.000	YDNAC KLAMMER 10101 (9MM)	YDNAC CLAMP 10101 (9MM)	2
80	306054	BREMSFLÜSSIGKEIT DOT 5.1	BRAKE FLUID DOT 5.1	1

FIG	TEILNR/PARTNR	BEZEICHNUNG	DESCRIPTION	QTY
8	0015 120556	SK.BUNDSCHRAUBE M12X55 SW=13	HH COLLAR SCREW M12X55 WS=13	2
10*	1218.T715	MONOSHOCK WP PDS 125 EXE 2000	MONOSHOCK WP PDS 125 EXE 2000	1
11	9121.0009	+ FEDER PDS1-250	SPRING PDS1-250	1
11	9121.0010	+ FEDER PDS2-250	SPRING PDS2-250	X
11	9121.0011	+ FEDER PDS3-250	SPRING PDS3-250	X
12	5018.0186	+ EINSTELLR. FEDER PDS M6 2000	SPRINGRETAINER PDS M6 2000	1
18	503.04.018.000	GEWINDEBÜCHSE M12 PDS '98	BUSHING M12 PDS '98	1
20	5018.0151S	+ BÜCHSE+LAGER KPL.PDS 12MM'99	BUSH+BEARINGS CPL. PDS 12MM'99	1
30	R120.04	+ REP.SATZ. DICHRINGE PDS '99	REP.KIT GASKET RINGS PDS '99	1

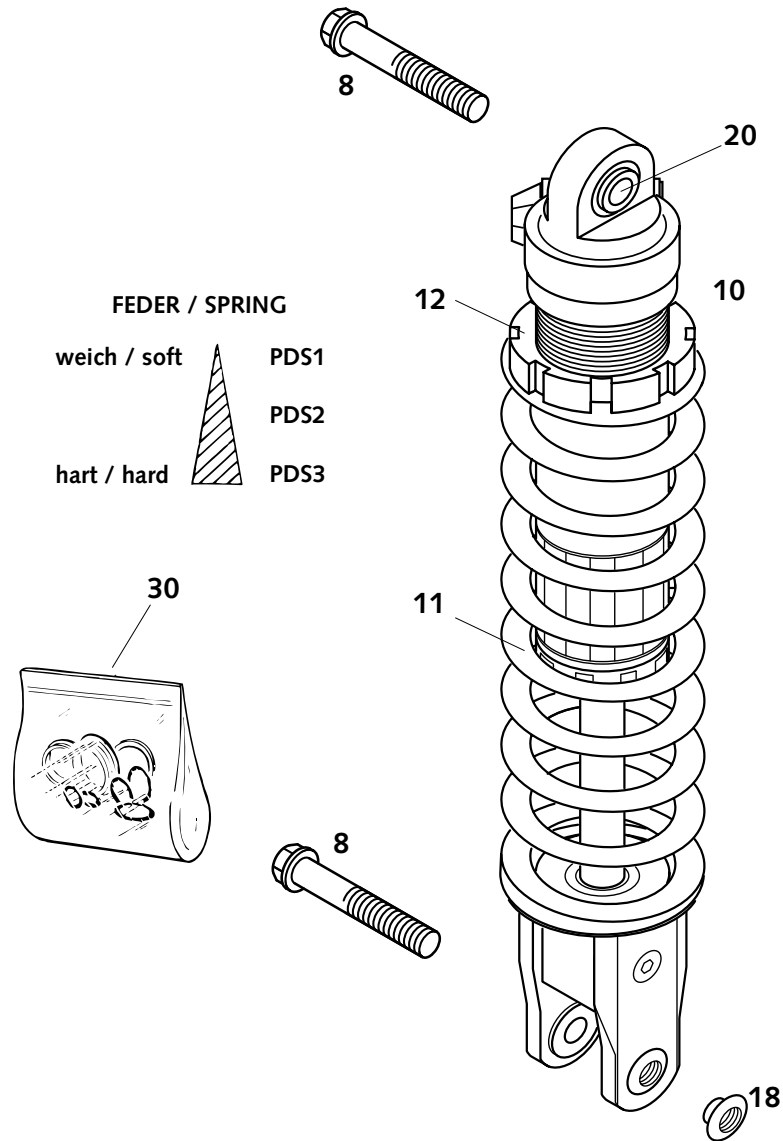

FIG	TEILNR/PARTNR	BEZEICHNUNG	DESCRIPTION	QTY
7*	512.05.009.000	AUSPUFF EXE M.KAT „512 0“ 2000	EXH.PIPE W.KAT EXE „512 0“2000	1
7*	512.05.009.100	AUSPUFF EXE M.KAT „512 8“ 2000	EXH.PIPE W.KAT EXE „512 8“2000	1
9	503.05.016.000	ZUGFEDER L=55MM ÖSEN BEWEGLICH	TENSION SPRING L=55MM	2
8	0770 440030	O-RING 44,00X3,00 VITON	O-RING 44,00X3,00 VITON	2
11	546.05.157.000	SILIKON-MUFFE D=25/27MM	SILICON SLEEVE D=25/27MM	1
12	503.05.012.000	SCHWINGELEMEN FÜR AUSPUFF '98	SWINGELEMEN FOR EX.PIPE '98	2
13	0014 060153	SK.BUNDSCHRAUBE M 6X15 SW=8	HH COLLAR SCREW M 6X15 WS=8	2
14	0014 060103	SK.BUNDSCHRAUBE M 6X10 SW=8	HH COLLAR SCREW M 6X10 WS=8	2
16	546.03.048.100	MEHRBEREICHSBLECHMUTTER M6	RANGE CHANGE METAL NUT M6	2

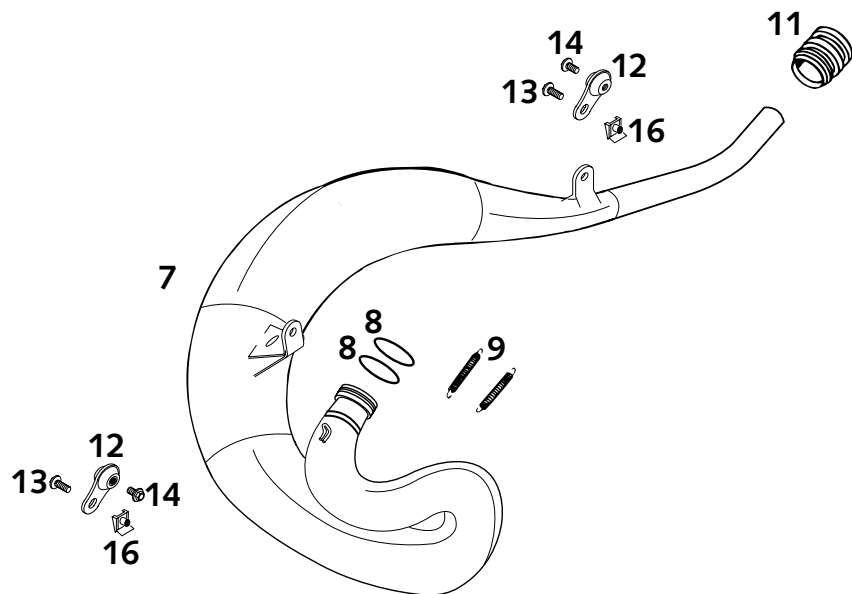
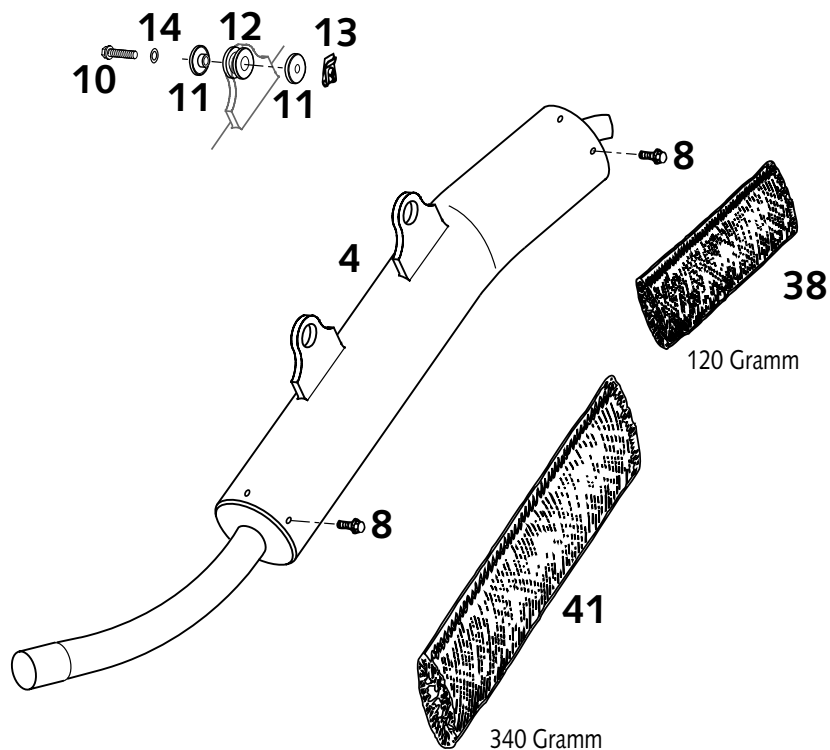



FIG	TEILNR/PARTNR	BEZEICHNUNG	DESCRIPTION	QTY
4*	512.05.083.000	ENDDÄMPFER KPL. 125 EXE 2000 „KTM EGS1 E1“	EXH.SILENCER CPL. 125 EXE 2000 „KTM EGS1 E1“	1
8	0009 050103	GEW.FURCHSCHRAUBE M 5,0X10	SPECIAL SCREW M 5,0X10	8
10	0015 060303	SK.BUNDSCHRAUBE M 6X30 SW=8	HH COLLAR SCREW M 6X30 WS=8	2
11	546.05.069.000	BÜCHSE 7,5X12X28X7,8 '96	BUSHING 7,5X12X28X7,8 '96	4
12	546.05.068.000	DÄMPFUNGELEMENT SCHWARZ	EXHAUST BRACKET RUBBER BLACK	2
13	546.03.048.100	MEHRBEREICHSBLECHMUTTER M6	RANGE CHANGE METAL NUT M6	2
14	0137 060000	FEDERSCHEIBE DIN0137-B 6	SPRING WASHER DIN0137-B 6	2
38	580.05.078.120	GLASFASERGARN 120 GRAMM HINTEN	STUFFING YARN 120 GRAMM REAR	1
41	580.05.078.340	GLASFASERGARN 340 GRAMM VORNE	STUFFING YARN 340 GRAMM FRONT	1



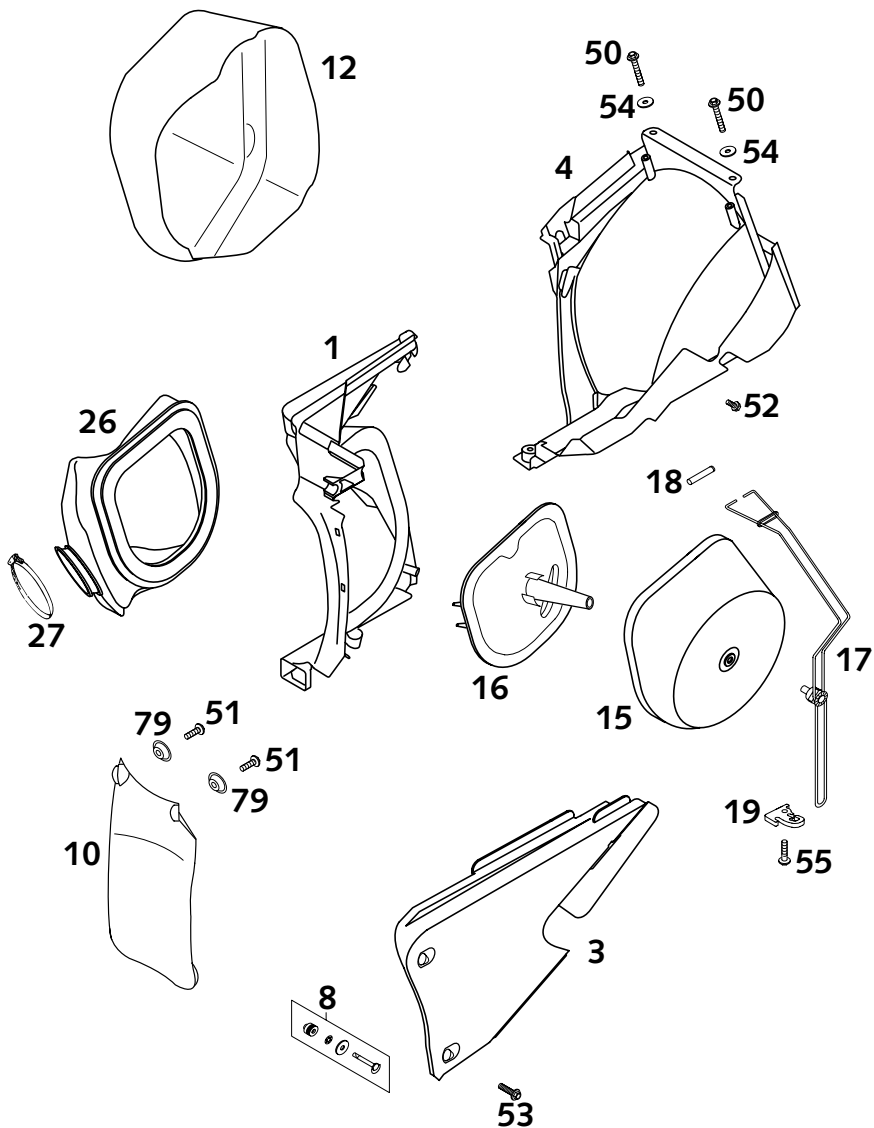

FIG	TEILNR/PARTNR	BEZEICHNUNG	DESCRIPTION	QTY
1	503.06.001.051	FILTERWAND 125-380 '98	FILTER WALL CPL. 125-380 '98	1
3	503.06.003.044	FILTERKASTENDECKEL KPL. 2T '98 MIT SCHNELLVERSCHLUSS	FILTER BOX COVER CPL. '98 WITH QUICK RELEASE	1
4	503.06.001.052	FILTERKASTENHINTERTEIL '98	FILTER BOX PART REAR '98	1
8	503.06.008.044	SCHNELLVERSCHLUSS KPL. '98	QUICK RELEASE CPL. '98	2
10	503.06.010.000	SPRITZSCHUTZ F.FILTERKASTEN'98	FENDER FOR FILTER BOX '98	1
12	503.06.012.000	DROSSELKAPPE 125-380EGS KPL.'98	THROTTLE CAP 125-380 EGS '98	1
15*	512.06.015.000	LUFTFILTER 125 EXE 2000	AIR FILTER 125 EXE 2000	1
16*	512.06.016.000	FILTERTRÄGER 125 EXE 2000	FILTER CARRIER 125 EXE 2000	1
17	503.06.017.000	FILTERHALTEBÜGEL KPL. 2TAKT'98	FILTER SUPPORT CPL.2-STROKE'98	1
18	503.06.018.000	FILTERTRÄGERHÜLSE 125-380 '98	FILTER SUPPORT BUSH 125-380'98	1
19	503.06.019.000	BEFESTIGUNGSBLECH FILTERBÜGEL	FASTEN. DEVICE FILTER SUPPORT	1
26	547.06.026.000	VERGASERMANSCHETTE 125-380 '98	CARBURETOR CONNECTION BOOT '98	1
27	510.06.027.000	SCHLAUCHBINDER 50-70MM	HOSE CLAMP 50-70MM	1
50	0017 060403	SONDERSCHRAUBE T60 6X40	SPECIAL SCREW T60 6X40	2
51	0017 060203	SONDERSCHRAUBE T60 6X20	SPECIAL SCREW T60 6X20	2
52	0009 050103	GEW.FURCHSCHRAUBE M 5,0X10	SPECIAL SCREW M 5,0X10	1
53	0016 070253	KUNSTSTOFFSCHR. K7X25 PT1447	PLASTIC SCREW K7X25 PT1447	2
54	0125 060003	UNTERLEGSCHIBE DIN0125-A 6,4	WASHER DIN0125-A 6,4	2
55	0017 060303	SONDERSCHRAUBE T60 6X30	SPECIAL SCREW T60 6X30	1
79	722.10.079.000	STÜTZSCHALE	BUCKET	2

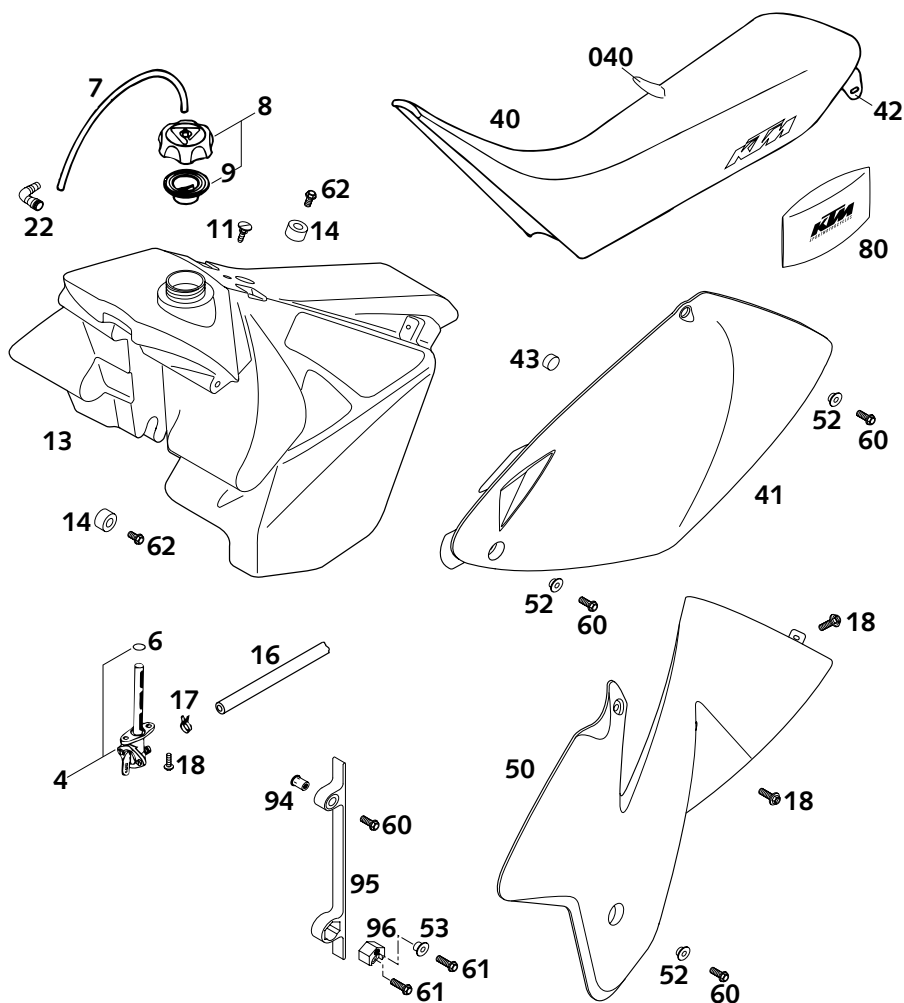

FIG	TEILNR/PARTNR	BEZEICHNUNG	DESCRIPTION	QTY
4	583.07.105.200	BENZINHAHN KPL. OFF-ON-RES	FUEL COCK CPL. OFF-ON-RES	1
6	550.07.006.200	O-RING 11X1,8 NBR 70	O-RING 11X1,8 NBR 70	1
7	310.07.107.001	PVC-SCHLAUCH 6X9 MM PER METER	PVC-HOSE 6X9 MM PER METER	0,25
8	590.07.008.044	TANKVERSCHL.KPL.KLEIN EUROPA	FILLER CAP CPL. SMALL EUROPE	1
9	490.07.009.000	DICHTUNG FÜR TANKVERSCHLUSS	GASKET FOR FILLER CAP	1
11	503.07.011.000	SCHRAUBE SITZBANKBEF. '98	SCREW SEAT FASTENING '98	1
13	523.07.013.000	BENZINTANK KPL. 12 LITER '98	FUEL TANK CPL. 12 LITER '98	1
14	503.07.014.000	TANKROLLE 12X26X12 '98	TANK ROLLER 12X26X12 '98	3
16	544.35.024.001	ND-SCHLAUCH ID 7,5 PER METER	HOSE ID 7,5 PER METER	0,23
17	580.07.117.000	YDNAC-KLAMMER 10107 10MM	YDNAC-KLAMMER 10107 10MM	2
18	0017 060203	SONDERSCHRAUBE T60 6X20	SPECIAL SCREW T60 6X20	8
22	510.30.022.000	WINKELSTÜCK 90 GRAD M10X1	ANGLE PIECE 90 DEGREE M10X1	1
40*	512.07.040.000	SITZBANK SCHWARZ 125 EXE 2000	SEAT BLACK 125 EXE 2000	1
40*	512.07.040.050	SITZB.ÜBERZ.SCHW./KTM EXE 2000	SEAT COVER BLACK/KTM EXE 2000	1
41	503.08.041.000/90	SEITENVERKL. LINKS SILBER '98	SIDE COVER L/S SILVER '98	1
—	503.08.042.000/90	SEITENVERKL. RECHTS SILBER '98	SIDE COVER R/S SILVER '98	1
42	503.07.041.000	SITZBANKHALTEWINKEL LI/RE '98	SEAT BRACKET L/S-R/S '98	2
43	503.08.042.055	GUMMI FÜR SEITENVERKLEIDUNG'98	RUBBER FOR SIDE COVER '98	2
50	503.08.050.000/04	SPOILER LINKS ORANGE '98	SPOILER L/S ORANGE '98	1
—	523.08.051.000/04	SPOILER RECHTS ORANGE SGP '99	SPOILER R/S ORANGE SGP '99	1
52	503.08.052.000	BÜCHSE FÜR SPOILER 6X11X16X5	BUSH FOR SPOILER 6X11X16X5	6
53	503.08.053.000	BÜCHSE FÜR SPOILER 6X11X16X7,5	BUSH FOR SPOILER 6X11X16X7,5	1
60	0015 060163	SK.BUNDSCHRAUBE M 6X16 SW=8	HH COLLAR SCREW M 6X16 WS=8	7
61	0015 060203	SK.BUNDSCHRAUBE M 6X20 SW=8	HH COLLAR SCREW M 6X20 WS=8	2
62	0015 060120	SK.BUNDSCHRAUBE M 6X12 M.SICH.	HH COLLAR SCREW M 6X12 W.LOCK	3
80	502.12.100.100	BORDWERKZEUG 125-380 ORANGE'97	TOOL SET 125-380 ORANGE '97	1
94	550.03.139.600	BLINDNIETMUTTER M6X15,5 STAHL	BLIND RIVET NUT M6X15,5 STEEL	1
95	503.35.095.000	SPOILERADAPTER 12 LI. TANK '98	SPOILER ADAPTER 12 LI. TANK'98	1
96	503.35.096.000	TANKADAPTERBÜCHSE 12 LITER '98	TANK ADAPTER BUSH 12 LITER '98	1

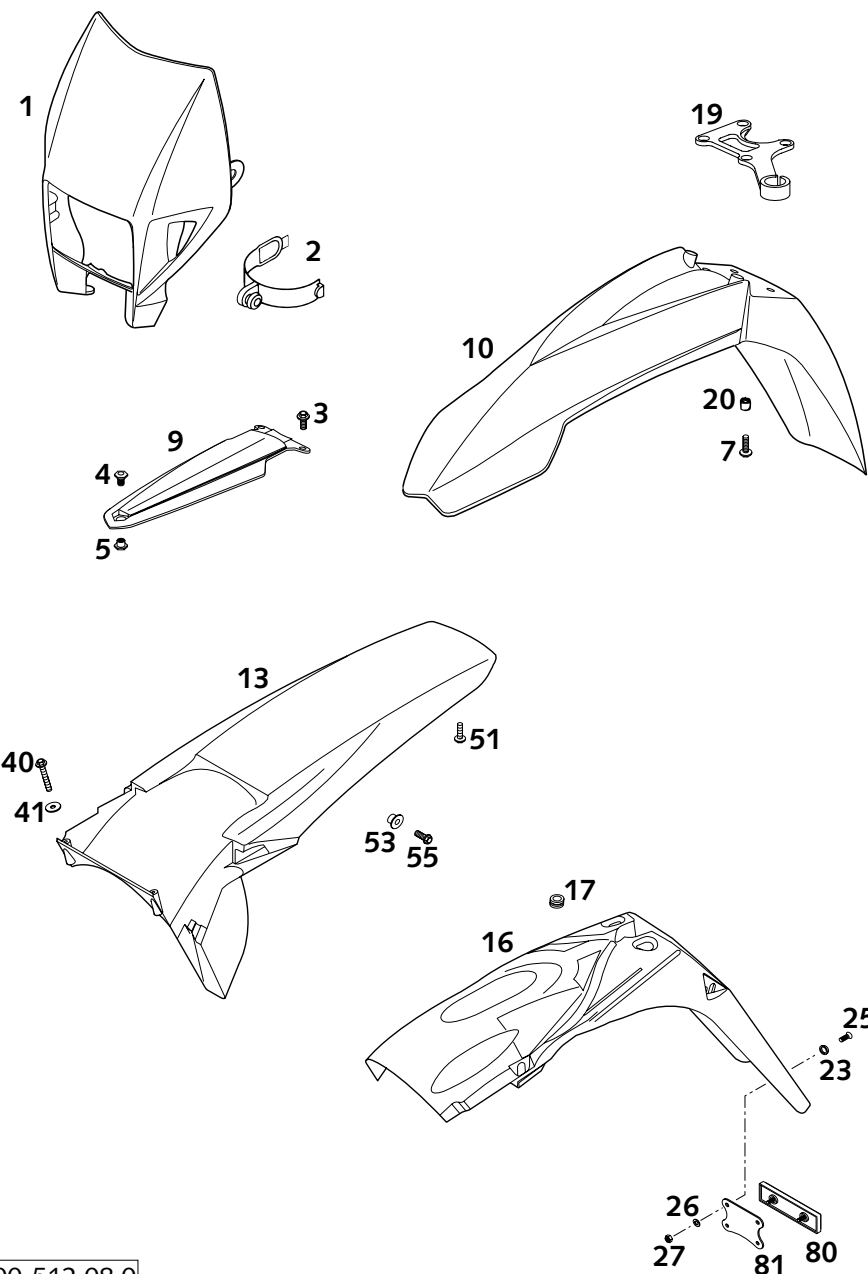
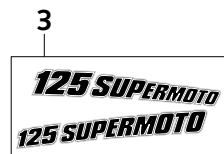
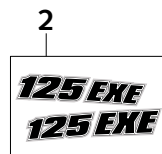
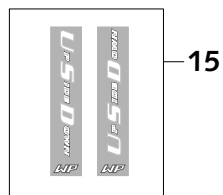
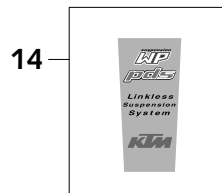
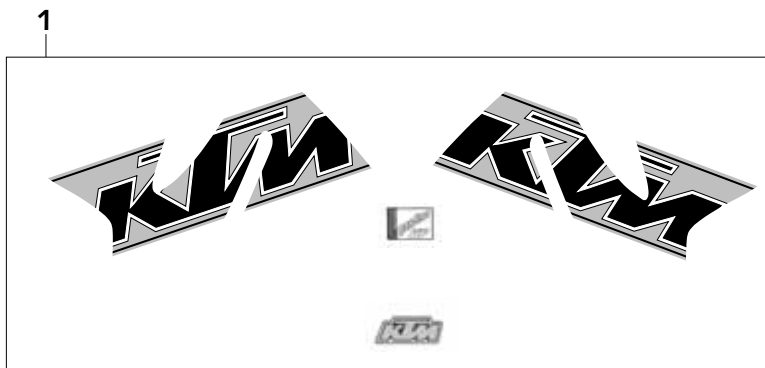

FIG	TEILNR/PARTNR	BEZEICHNUNG	DESCRIPTION	QTY
1	503.08.001.000/04	SCHEIN.MASKE ORANGE EXC/EGS'99	H.LIGHT MASK ORANGE EXC/EGS'99	1
2	502.11.086.000	MASKENGUMMI UFO WP '95	MASK RUBBER UFO WP '95	2
3	0014 060153	SK.BUNDSCHRAUBE M 6X15 SW=8	HH COLLAR SCREW M 6X15 WS=8	2
4	503.08.009.050	SCHRAUBE KOTFL.STR.M8X9 SW=17	SCREW FEND.BRACE M8X9 WS=17	1
5	503.08.009.051	MUTTER KOTFL.STR. M8 SW=17	NUR FENDER BRACE M8 WS=17	1
7	0014 060203	SK.BUNDSCHRAUBE M 6X20 SW=8	HH COLLAR SCREW M 6X20 WS=8	4
9	503.08.009.100	KOTFLÜGELSTREBE SCHWARZ '99	FENDER BRACE BLACK '99	1
10	503.08.010.100/04	KOTFLÜGEL VORNE ORANGE '99	FENDER FRONT ORANGE '99	1
13	503.08.013.100/90	KOTFLÜGEL HINTEN EXC SILBER'98	REAR FENDER EXC SILVER '98	1
16	503.08.015.100	NUMMERTAFELTRÄGER 2T EGS '98	NUMBER PLATE CARRIER EGS '98	1
17	310.08.060.000	KABELTÜLLE D=8MM OFFEN	RUBBER SLEEVE D=8MM OPEN	1
19	590.08.019.000	BREMSSCHLAUCHFÜHRUNG 2000	BRAKE HOSE GUIDE 2000	1
20	502.08.020.000	DISTANZBÜCHSE 7X10X7,5	SPACER BUSHING 7X10X7,5	4
23	400.06.006.000	FASSONSCHIBE 6MM	WASHER 6MM	2
25	0966 050163	LI.SENKSCHRAUBE DIN0966-M 5X16	OVAL HEAD SCREW DIN0966-M 5X16	2
26	0125 050003	UNTERLEGSCHIBE DIN0125-A 5,0	WASHER DIN0125-A 5,0	2
27	0985 050003	SS.MUTTER DIN0985-M 5	SELF LOCKING NUT DIN0985-M 5	2
40	0017 060403	SONDERSCHRAUBE T60 6X40	SPECIAL SCREW T60 6X40	2
41	0125 060003	UNTERLEGSCHIBE DIN0125-A 6,4	WASHER DIN0125-A 6,4	2
51	0017 060203	SONDERSCHRAUBE T60 6X20	SPECIAL SCREW T60 6X20	2
53	503.08.053.100	BÜCHSE F.NUM.TRÄG. 6X11X22X9,5	BUSH F.NUM.PL. CAR. 6X11X22X9,5	2
55	0015 060163	SK.BUNDSCHRAUBE M 6X16 SW=8	HH COLLAR SCREW M 6X16 WS=8	2
80	584.12.080.000	RÜCKSTRAHLER ROT LC4 '98	REFLECTOR RED LC4 '98	1
81	584.12.080.050	HALTERUNG FÜR RÜCKSTRAHLER	BRACKET FOR REFLECTOR	1

FIG	TEILNR/PARTNR	BEZEICHNUNG	DESCRIPTION	QTY
1	503.08.090.200	SPOILERDEKOR KPL.125-380 2000	SPOILER DECAL CPL.125-380 2000	1
2*	512.08.098.000	HUBRAUMDEKOR „125 EXE“ 2000	DISPLACEM.DECAL „125 EXE“ 2000	1
3*	512.08.098.100	HUBRAUMDEKOR „125 S.MOTO“ 2000	DISPLACEM.DECAL „125S.MOTO“2000	1
14	503.08.095.000	DEKOR SPONSOREN HECK SX 2000	DECAL SPONSORS REAR SX 2000	X
15	503.08.093.100	AUFKLEBER „UP SIDE DOWN WP“	DECAL „UP SIDE DOWN WP“	1



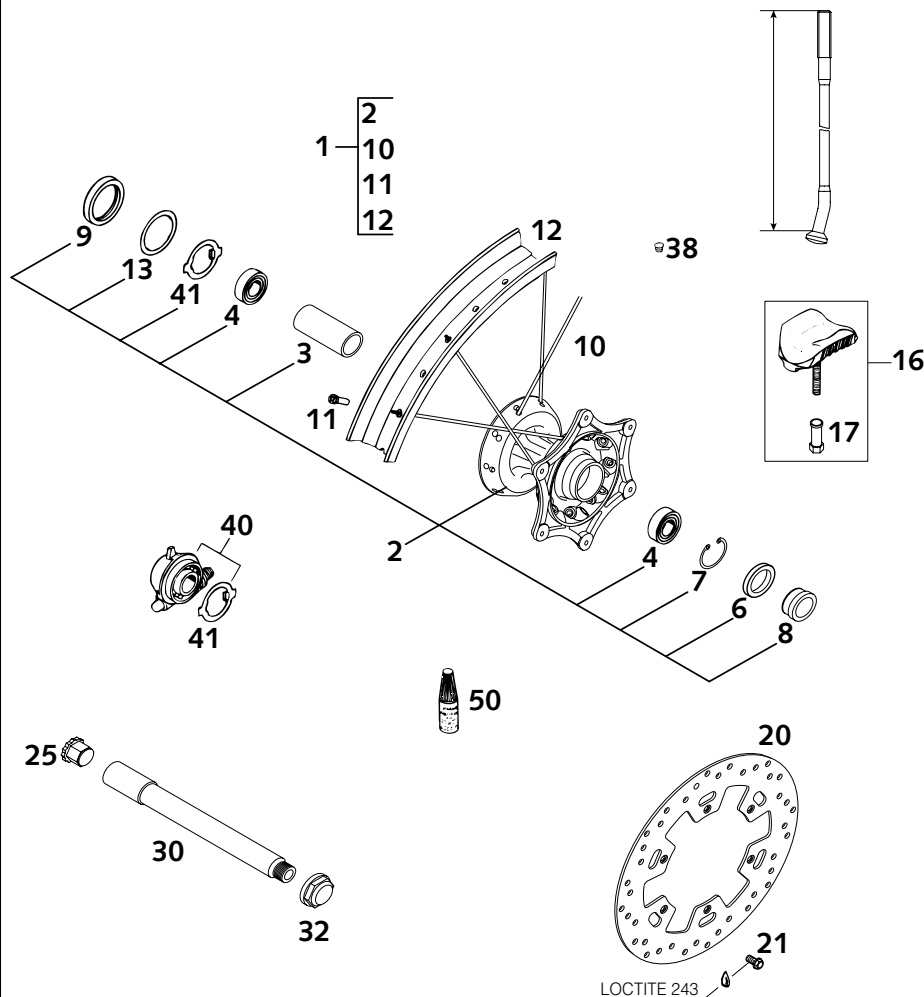

FIG	TEILNR/PARTNR	BEZEICHNUNG	DESCRIPTION	QTY
1	503.09.001.244	VORDERRAD 1,6X21" DID EXC 2000	FRONTWHEEL 1,6X21" DID EXC 2000	1
2	503.09.010.144	VORDERRADNABE KPL. EXC 2000	FRONT HUB CPL. EXC 2000	1
3	503.09.011.100	LAGERDISTANZROHR 20,5X25X63,3	BEAR. SPACERTUBE 20,5X25X63,3	1
4	0625 069047	RILLENKUGELL. NSK 6904 2RSRC3	GROOV.BALL BEAR.NSK6904 2RSRC3	2
6	0760 263770	WELLENDICHTRING 26X37X7 ASL	SHAFT SEAL RING 26X37X7 ASL	1
7	0472 037154	SICHERUNGSRING DIN0472-37X1,5	LOCK RING DIN0472-37X1,5	1
8	503.09.012.000	DISTANZBÜCHSE 20X26X27,8 2000	SPACER BUSHING 20X26X27,8 2000	1
9	0760 405270	WELLENDICHTRING 40X52X7 B	SHAFT SEAL RING 40X52X7 B	1
10	503.09.071.230	SPEICHE M4,5X230-15G 21" DDE	SPOKE M4,5X230-15G 21" DDE	36
11	503.09.072.000	SPEICHENNIPPEL M4,5X0,75 8X21	SPOKE NIPPLE M4,5X0,75 8X21	36
12	546.09.070.200	FELGE VORNE 1,6X21" DID	FRONT RIM 1,6X21" DID	1
13	581.11.054.000	SCHEIBE 40 X 52 X 0,15 '92	WASHER 40 X 52 X 0,15 '92	1
16	510.09.100.100	REIFENHALTER VM1 (1,60")	RIM LOCK VM1 (1,60")	X
17	503.10.090.050	MUTTER FÜR REIFENHALTER '96	NUT WHEEL HOLDER '96	X
20	511.09.060.000	BREMSSCHEIBE VORNE 260MM '96	FRONT BRAKE DISC 260 MM '96	1
21	0015 060120	SK.BUNDSCHRAUBE M 6X12 M.SICH.	HH COLLAR SCREW M 6X12 W.LOCK	6
25	503.09.081.150	HALTEGRIF F. STECKACHSE SW=21	HANDLE FOR FRONT AXLE WS=21	1
30	503.09.081.100	STECKACHSE VO. USD43 188,5MM	AXLE FRONT USD43 188,5MM	1
32	503.09.082.000	BUNDMUTTER VORNE M16X1,5 SW=27	COLLAR NUT FRONT M16X1,5 WS=27	1
38	550.03.135.000	BLINDSTOPFEN FÜR FELGE	PLUG FOR RIM	X
40	503.14.050.000	TACHOANTRIEB 748220 (3.0) 2000	SPEEDOMETER DRIVE 748220 (3.0)	1
41	503.14.053.000	MITNEHMER F. TACHOANTRIEB 2000	DRIV.DOG F.SPEEDOM.DRIVE 2000	1
50	6 899 785	LOCTITE 243 BLAU 6CCM	LOCTITE 243 BLUE 6CCM	1

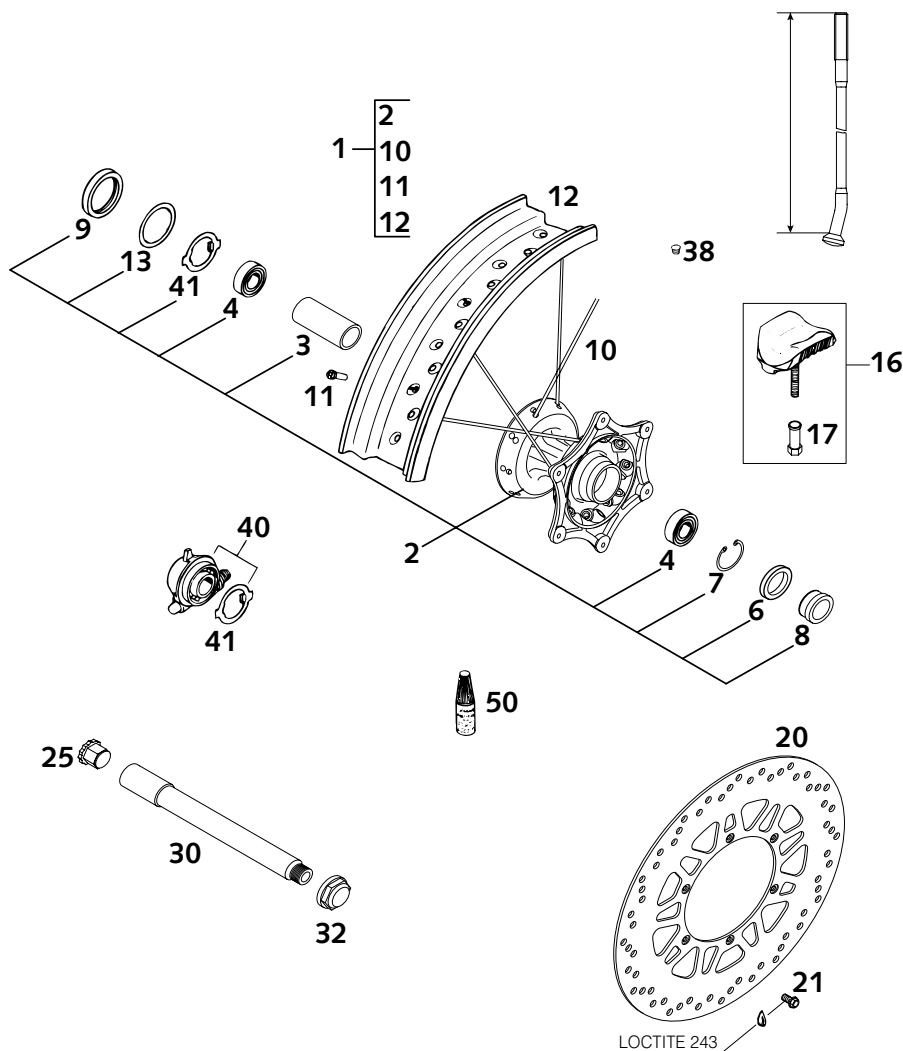
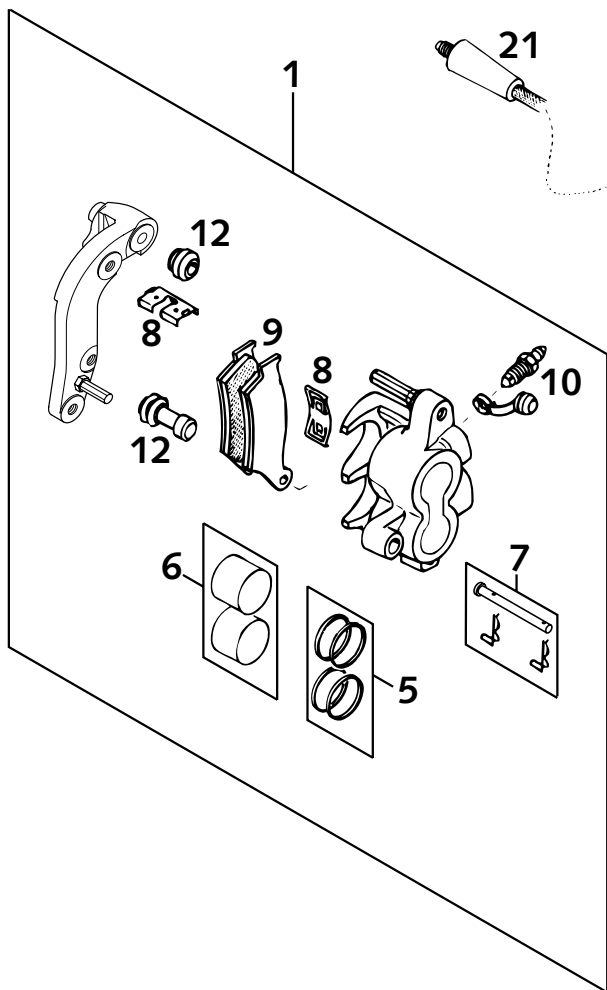

FIG	TEILNR/PARTNR	BEZEICHNUNG	DESCRIPTION	QTY
1*	512.09.001.044	VORDERRAD 2,5X17" S.MOTO 2000	FRONT WHEEL 2,5X17" S.MOTO 2000	1
2	503.09.010.144	VORDERRADNABE KPL. EXC 2000	FRONT HUB CPL. EXC 2000	1
3	503.09.011.100	LAGERDISTANZROHR 20,5X25X63,3	BEAR. SPACERTUBE 20,5X25X63,3	1
4	0625 069047	RILLENKUGELL. NSK 6904 2RSRC3	GROOV.BALL BEAR.NSK6904 2RSRC3	2
6	0760 263770	WELLENDICHTRING 26X37X7 ASL	SHAFT SEAL RING 26X37X7 ASL	1
7	0472 037154	SICHERUNGSRING DIN0472-37X1,5	LOCK RING DIN0472-37X1,5	1
8	503.09.012.000	DISTANZBÜCHSE 20X26X27,8 2000	SPACER BUSHING 20X26X27,8 2000	1
9	0760 405270	WELLENDICHTRING 40X52X7 B	SHAFT SEAL RING 40X52X7 B	1
10*	503.09.071.174	SPEICHE M4,5X174-15G 17" DDE	SPOKE M4,5X174-15G 17" DDE	36
11	503.09.072.000	SPEICHENNIPPEL M4,5X0,75 8X21	SPOKE NIPPLE M4,5X0,75 8X21	36
12	511.09.070.100	FELGE VORNE 2,50X17" STING'97	FRONT RIM 2,50X17" STING'97	1
13	581.11.054.000	SCHEIBE 40 X 52 X 0,15 '92	WASHER 40 X 52 X 0,15 '92	1
16	510.09.100.100	REIFENHALTER VM1 (1,60")	RIM LOCK VM1 (1,60")	X
17	503.10.090.050	MUTTER FÜR REIFENHALTER '96	NUT WHEEL HOLDER '96	X
20	511.09.060.100	BREMSSCHEIBE VORNE 320MM STING	BRAKE DISC FRONT 320MM STING	1
21	0015 060120	SK.BUNDSCHRAUBE M 6X12 M.SICH.	HH COLLAR SCREW M 6X12 W.LOCK	6
25	503.09.081.150	HALTEGRIF F. STECKACHSE SW=21	HANDLE FOR FRONT AXLE WS=21	1
30	503.09.081.100	STECKACHSE VO. USD43 188,5MM	AXLE FRONT USD43 188,5MM	1
32	503.09.082.000	BUNDMUTTER VORNE M16X1,5 SW=27	COLLAR NUT FRONT M16X1,5 WS=27	1
38	550.03.135.000	BLINDSTOPFEN FÜR FELGE	PLUG FOR RIM	X
40	503.14.050.100	TACHOANTRIEB 748233 (2.66) 17"	SPEEDOMETER DRIVE 748233(2.66)	1
41	503.14.053.000	MITNEHMER F. TACHOANTRIEB 2000	DRIV.DOG F.SPEEDOM.DRIVE 2000	1
50	6 899 785	LOCTITE 243 BLAU 6CCM	LOCTITE 243 BLUE 6CCM	1



VORNE  
FRONT

FIG	TEILNR/PARTNR	BEZEICHNUNG	DESCRIPTION	QTY
1	590.13.015.144	BREMSZANGE VO.KPL.BREMBO 2000	BRAKECALIPER FRONT BREMBO 2000	1
5	546.13.205.000	REPARATURSATZ 28MM	REPAIR KIT 28MM	1
6	546.13.206.000	REPARATUR SATZ KOLBEN 28MM	REPAIR KIT PISTON 28MM	1
7	546.13.210.100	BOLZEN KPL. 6X56	BOLT CPL. 6X56	1
8	546.13.212.000	HALBLECHE GARNITUR BREMBO	RETAINING PLATE SET BREMBO	1
9	503.13.030.000	GARN.BREMSKLÖTZE TOSHIBA H38	BRAKE PAD SET TOSHIBA H38	X
9	546.13.209.044	GARN. BREMSKLÖTZE FERODO ID450	BRAKE PAD SET FERODO ID450	1
10	545.13.214.000	ENTLÜFTUNGSSCHRAUBE M10X1	BLEEDER SCREW M10X1	1
12	546.13.218.000	MANSCHETTENSATZ	CUP SET SHORT	1
15	0015 080350	SK.BUNDSCHRAUBE M 8X35 M.SICH.	HH COLLAR SCREW M 8X35 W.LOCK	2
21*	512.13.011.000	BREMSSCHL. VO. 1210MM EXE 2000	BRAKEHOSE FRONT 1210MM EXE2000	1
30	420.13.226.000	CU-DICHTRING DIN7603-10X16X1	CU-SEAL RING DIN7603-10X16X1	2
31	420.13.026.000	CU-DICHTRING DIN7603-10X16X1,5	CU-SEAL RING DIN7603-10X16X1,5	2
35	502.13.025.000	HOHLSCHRAUBE M10X1X19	HOLLOW SCREW M10X1X19	1
60	6 899 785	LOCTITE 243 BLAU 6CCM	LOCTITE 243 BLUE 6CCM	1



FIG	TEILNR/PARTNR	BEZEICHNUNG	DESCRIPTION	QTY
1	584.13.015.244	BREMSZANGE VO.KPL. 320MM 2000	BRAKECAL.FRONT CPL. 320MM 2000	1
5	546.13.205.000	REPARATURSATZ 28MM	REPAIR KIT 28MM	1
6	546.13.206.000	REPARATUR SATZ KOLBEN 28MM	REPAIR KIT PISTON 28MM	1
7	546.13.210.100	BOLZEN KPL. 6X56	BOLT CPL. 6X56	1
8	546.13.212.000	HALBLECHE GARNITUR BREMBO	RETAINING PLATE SET BREMBO	1
9	584.13.030.000	GARN.BREMSKLÖTZE TEXTART4069GF	BRAKE PAD SET TEXTAR T4069 GF	1
9	546.13.209.044	GARN. BREMSKLÖTZE FERODO ID450	BRAKE PAD SET FERODO ID450	X
10	545.13.214.000	ENTLÜFTUNGSSCHRAUBE M10X1	BLEEDER SCREW M10X1	1
12	546.13.218.000	MANSCHETTENSATZ	CUP SET SHORT	1
15	0015 080350	SK.BUNDSCHRAUBE M 8X35 M.SICH.	HH COLLAR SCREW M 8X35 W.LOCK	2
21*	512.13.011.000	BREMSSCHL. VO. 1210MM EXE 2000	BRAKEHOSE FRONT 1210MM EXE2000	1
30	420.13.226.000	CU-DICHTRING DIN7603-10X16X1	CU-SEAL RING DIN7603-10X16X1	2
31	420.13.026.000	CU-DICHTRING DIN7603-10X16X1,5	CU-SEAL RING DIN7603-10X16X1,5	2
35	502.13.025.000	HOHLSCHRAUBE M10X1X19	HOLLOW SCREW M10X1X19	1
60	6 899 785	LOCTITE 243 BLAU 6CCM	LOCTITE 243 BLUE 6CCM	1

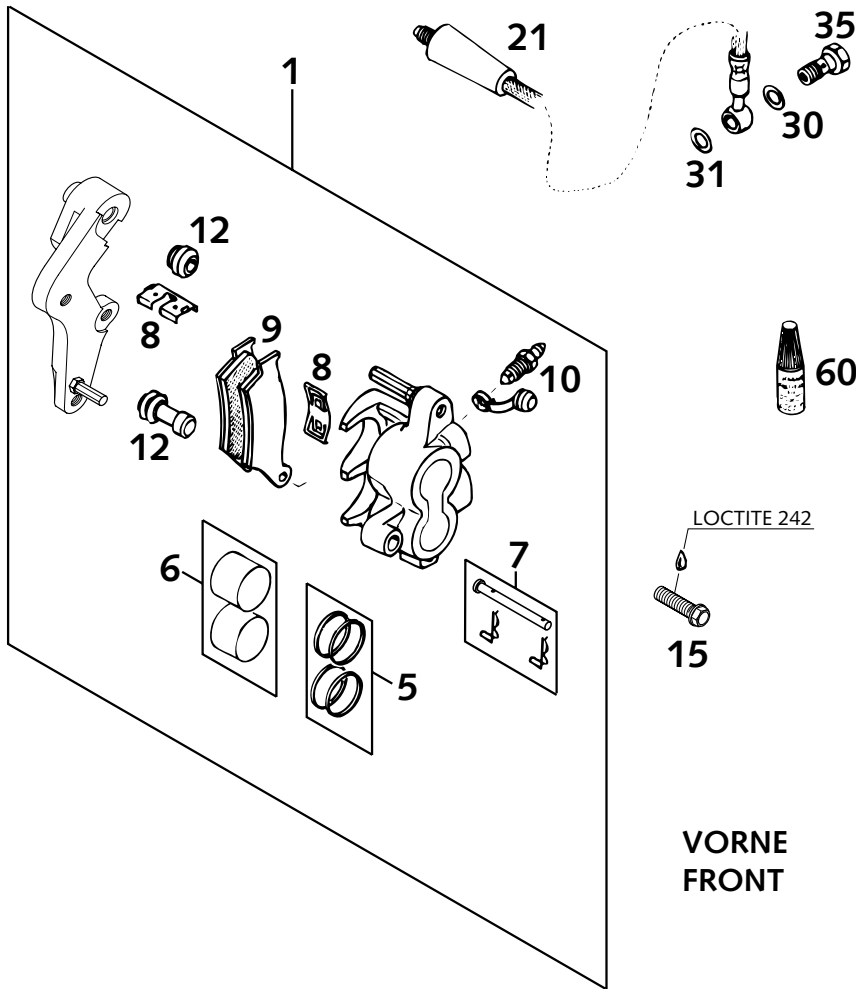

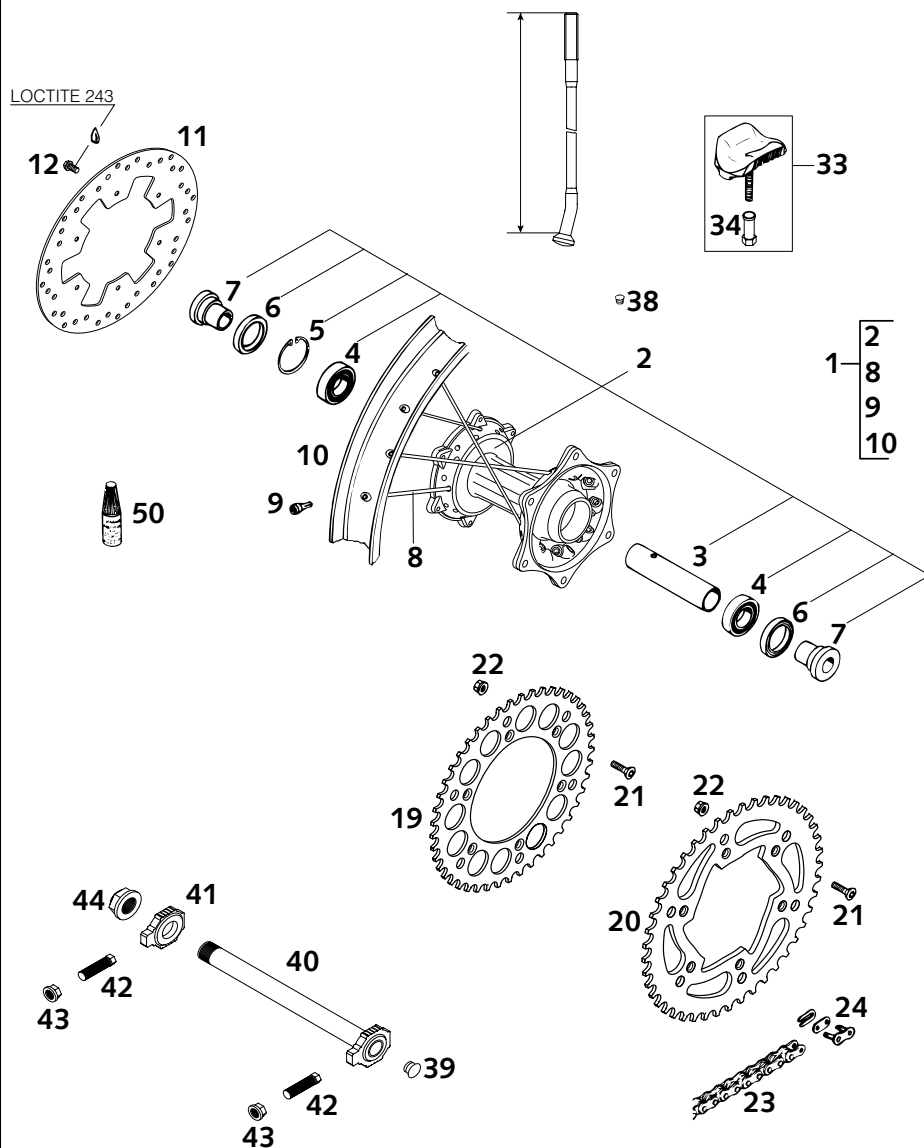

FIG	TEILNR/PARTNR	BEZEICHNUNG	DESCRIPTION	QTY
1	503.10.001.244	HINTERRAD KPL.2.15X18"DID 2000	REARWHEEL CPL.2.15X18"DID 2000	1
2	503.10.010.044	HINTERRADNABE KPL.125-380 2000	REARWHEEL HUB CPL.125-380 2000	1
3	565.10.011.000	LAGERDISTANZROHR 121,5 MM	BEARING SPACER TUBE 121,5MM	1
4	0625 060058	RILLENKUGELLAGER 6005 2RSR.C3	GROOVED BALL BEAR. 6005 2RS C3	2
5	0472 047175	SICHERUNGSRING DIN0472-47X1,75	CIRCLIP DIN0472-47X1,75	1
6	0760 324771	WELLENDICHTRING 32X47X7 BSL	SHAFT SEAL RING 32X47X7 BSL	2
7	546.10.016.000	BÜCHSE FÜR NABE	BUSHING FOR HUB	2
8	503.10.071.197	SPEICHE M5X197-10G 18" DDE	SPOKE M5X197-10G 18" DDE	36
9	583.09.072.000	STAHLNIPPEL M5 VERCHROMT	STEEL NIPPLE M5 CHROME PLATED	36
10	546.10.070.300	FELGE HINTEN 2,15X18" DID	REAR RIM 2,15X18" DID	1
11	511.10.060.000	BREMSSSCHEIBE HINTEN 220MM '96	REAR BRAKE DISC 220MM '96	1
12	0015 060120	SK.BUNDSCHRAUBE M 6X12 M.SICH.	HH COLLAR SCREW M 6X12 W.LOCK	6
19	583.10.051.038	KETTENRAD 38-Z	REAR SPROCKET 38-T	X
19	583.10.151.040	KETTENRAD 40-Z	REAR SPROCKET 40-T	1
19	583.10.051.042	KETTENRAD 42-Z	REAR SPROCKET 42-T	X
19	583.10.151.045	KETTENRAD 45-Z	REAR SPROCKET 45-T	X
20	583.10.151.048	KETTENRAD 48-Z	REAR SPROCKET 48-T	X
21	545.10.052.100	KETTENRADSCHR.-ISK M8X29 10.9	SPROCKET SCREW-AH M8X26 10.9	6
22	543.10.086.200	STOVER-FLANSCHMUTTER M8 10.9	SELF LOCKING NUT M8 10.9	6
23	511.10.065.000	O-RING KETTE 5/8X1/4" CZ 118 ROLLEN	O-RING CHAIN 5/8X1/4" CZ 118 ROLLS	1
23	511.10.065.001	O-RING KETTE 5/8X1/4" CZ	O-RING CHAIN 5/8X1/4"PER METER	1
24	511.10.066.000	KETTENSCHLOSS CZ O-RING KETTE	MASTER LINK CZ O-RING CHAIN	1
33	540.10.100.100	REIFENHALTER VM3 (2.15")	RIM LOCK VM3 (2.15")	X
34	503.10.090.050	MUTTER FÜR REIFENHALTER '96	NUT WHEEL HOLDER '96	X
38	550.03.135.000	BLINDSTOPFEN FÜR FELGE	PLUG FOR RIM	X
39	502.10.086.000	ABDECKKAPPE SFL16	COVERING CAP SFL16	1
40	503.10.085.044	STECKACHSE HINT.KPL.265MM 2000	AXLE REAR CPL. 265MM 2000	1
41	503.10.084.000	KETTENSCHNURER RECHTS 2000	CHAIN TENSIONER R/S 2000	1
42	503.04.040.000	SCHRAUBE M10X1,25 SW=10 2000	SPECIAL SCREW M10X1,25 WS=10	2
43	584.14.030.000	SK-BUNDMUTTER M10X1,25 SW=13	HH COLLAR NUT M10X1,25 WS=13	2
44	503.10.099.000	SK-MUTTER M20X1,5 '98	HEXAGON NUT M20X1,5 '98	1
50	6 899 785	LOCTITE 243 BLAU 6CCM	LOCTITE 243 BLUE 6CCM	1

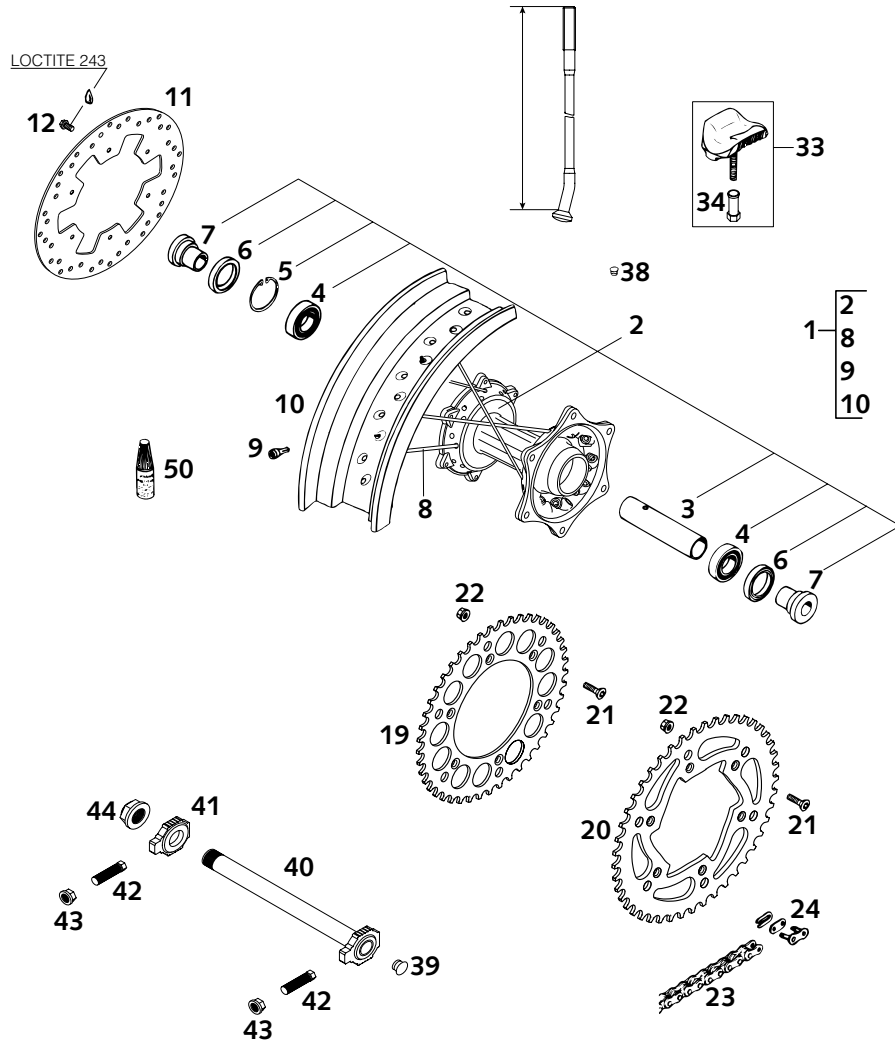

FIG	TEILNR/PARTNR	BEZEICHNUNG	DESCRIPTION	QTY
1*	512.10.001.044	HINTERR.KPL.3,5X17"S.MOTO 2000	R.WHEEL CPL.3,5X17"S.MOTO 2000	1
2	503.10.010.044	HINTERRADNABE KPL.125-380 2000	REARWHEEL HUB CPL.125-380 2000	1
3	565.10.011.000	LAGERDISTANZROHR 121,5 MM	BEARING SPACER TUBE 121,5MM	1
4	0625 060058	RILLENKUGELLAGER 6005 2RSR.C3	GROOVED BALL BEAR. 6005 2RS C3	2
5	0472 047175	SICHERUNGSRING DIN0472-47X1,75	CIRCLIP DIN0472-47X1,75	1
6	0760 324771	WELLENDICHTRING 32X47X7 BSL	SHAFT SEAL RING 32X47X7 BSL	2
7	546.10.016.000	BÜCHSE FÜR NABE	BUSHING FOR HUB	2
8	583.09.171.100	SPEICHE M5X177-13,5G 17"	SPOKE M5X177-13,5G 17"	36
9	583.09.072.000	STAHLNIPPEL M5 VERCHROMT	STEEL NIPPLE M5 CHROME PLATED	36
10	511.10.070.100	FELGE HINTEN 3,50X17" STING'97	REAR RIM 3,50X17" STING'97	1
11	511.10.060.000	BREMSSSCHEIBE HINTEN 220MM '96	REAR BRAKE DISC 220MM '96	1
12	0015 060120	SK.BUNDSCHRAUBE M 6X12 M.SICH.	HH COLLAR SCREW M 6X12 W.LOCK	6
19	583.10.051.038	KETTENRAD 38-Z	REAR SPROCKET 38-T	1
19	583.10.151.040	KETTENRAD 40-Z	REAR SPROCKET 40-T	X
19	583.10.051.042	KETTENRAD 42-Z	REAR SPROCKET 42-T	X
19	583.10.151.045	KETTENRAD 45-Z	REAR SPROCKET 45-T	X
20	583.10.151.048	KETTENRAD 48-Z	REAR SPROCKET 48-T	X
21	545.10.052.100	KETTENRADSCHR.-ISK M8X29 10.9	SPROCKET SCREW-AH M8X26 10.9	6
22	543.10.086.200	STOVER-FLANSCHMUTTER M8 10.9	SELF LOCKING NUT M8 10.9	6
23	511.10.065.000	O-RING KETTE 5/8X1/4" CZ 118 ROLLEN	O-RING CHAIN 5/8X1/4" CZ 118 ROLLS	1
23	511.10.065.001	O-RING KETTE 5/8X1/4" CZ	O-RING CHAIN 5/8X1/4" PER METER	1
24	511.10.066.000	KETTENSCHLOSS CZ O-RING KETTE	MASTER LINK CZ O-RING CHAIN	1
33	540.10.100.100	REIFENHALTER VM3 (2.15")	RIM LOCK VM3 (2.15")	X
34	503.10.090.050	MUTTER FÜR REIFENHALTER '96	NUT WHEEL HOLDER '96	X
38	550.03.135.000	BLINDSTOPFEN FÜR FELGE	PLUG FOR RIM	X
39	502.10.086.000	ABDECKKAPPE SFL16	COVERING CAP SFL16	1
40	503.10.085.044	STECKACHSE HINT.KPL.265MM 2000	AXLE REAR CPL. 265MM 2000	1
41	503.10.084.000	KETTENSANNER RECHTS 2000	CHAIN TENSIONER R/S 2000	1
42	503.04.040.000	SCHRAUBE M10X1,25 SW=10 2000	SPECIAL SCREW M10X1,25 WS=10	2
43	584.14.030.000	SK-BUNDMUTTER M10X1,25 SW=13	HH COLLAR NUT M10X1,25 WS=13	2
44	503.10.099.000	SK-MUTTER M20X1,5 '98	HEXAGON NUT M20X1,5 '98	1
50	6 899 785	LOCTITE 243 BLAU 6CCM	LOCTITE 243 BLUE 6CCM	1

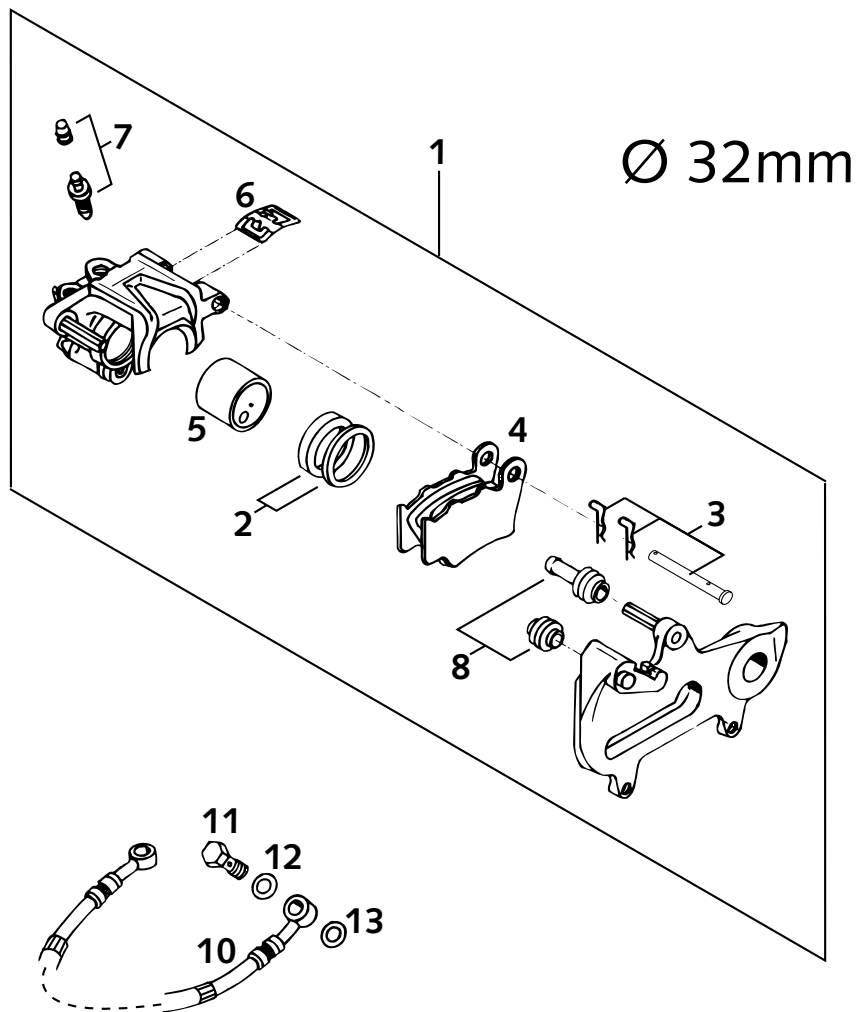

FIG	TEILNR/PARTNR	BEZEICHNUNG	DESCRIPTION	QTY
1	503.13.080.044	BREMSZANGE HINTEN BREMBO '99	BRAKE CALIPER REAR BREMBO '99	1
2	503.13.081.000	REP.SATZ DICHRINGE 32MM	REPAIR KIT SEALING RINGS 32MM	1
3	503.13.082.000	BOLZENSATZ FÜR BREMSZANGE 32MM	BOLT SET F. BRAKE CALIPER 32MM	1
4	546.13.309.200	GARN. BREMSKLÖTZE FERODO ID450	BRAKE PAD SET FERODO ID450	1
4	546.13.309.400	GARN. BREMSKLÖTZE FERRIT222	BRAKE PAD SET FERRIT222	X
5	503.13.083.000	BREMSKOLBEN 32MM	BRAKE PISTON 32MM	1
6	546.13.311.200	HALTEFEDER	RETAINING SPRING	1
7	545.13.214.000	ENTLÜFTUNGSSCHRAUBE M10X1	BLEEDER SCREW M10X1	1
8	546.13.218.000	MANSCHETTENSATZ	CUP SET SHORT	1
10	503.13.070.000	BREMSSCHL.HI. 590MM 125-380'98	BRAKE HOSE RE.590MM 125-380'98	1
11	502.13.025.000	HOHLSCHRAUBE M10X1X19	HOLLOW SCREW M10X1X19	1
12	420.13.226.000	CU-DICHTRING DIN7603-10X16X1	CU-SEAL RING DIN7603-10X16X1	1
13	420.13.026.000	CU-DICHTRING DIN7603-10X16X1,5	CU-SEAL RING DIN7603-10X16X1,5	1

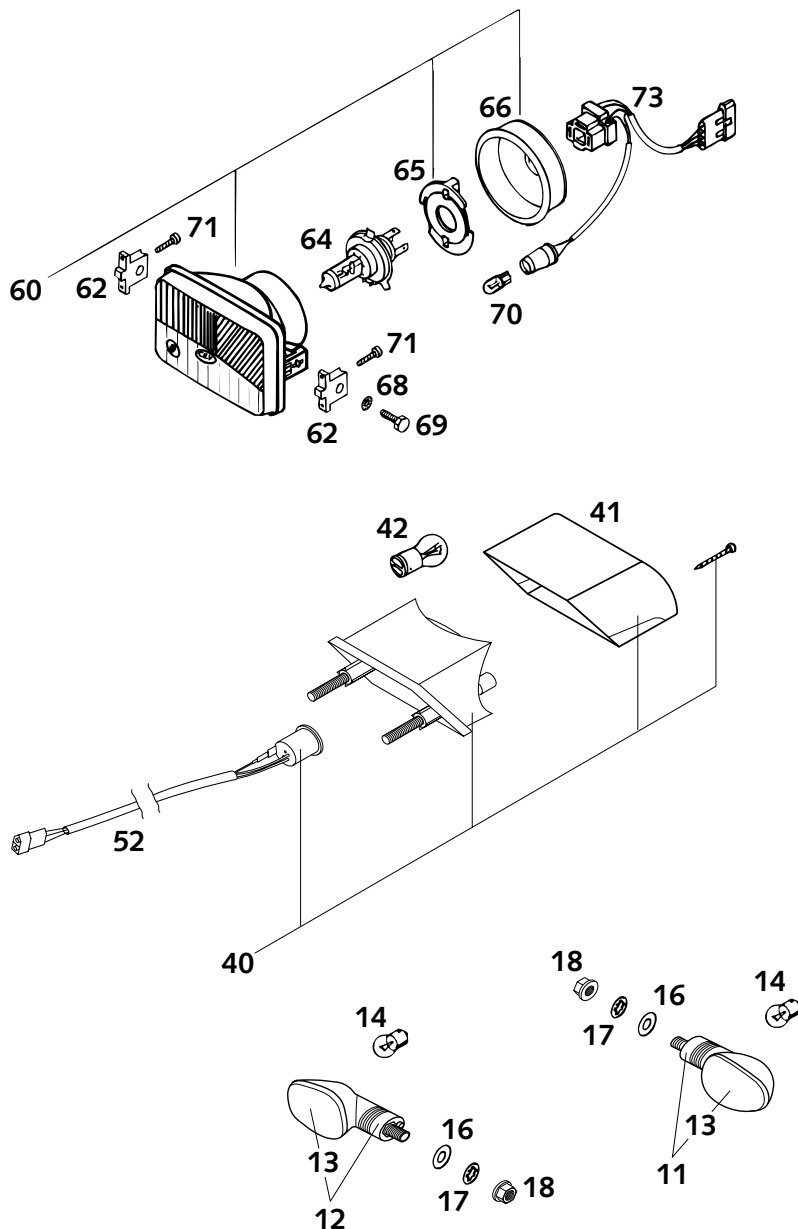
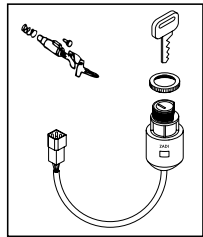
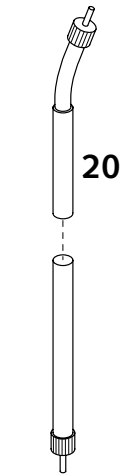
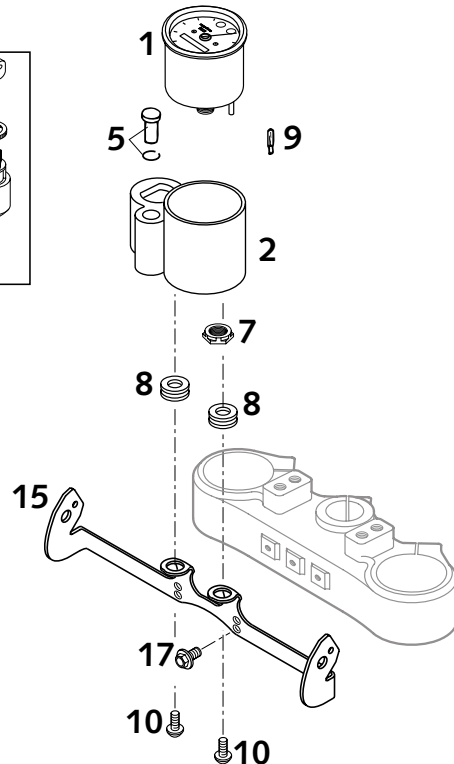

FIG	TEILNR/PARTNR	BEZEICHNUNG	DESCRIPTION	QTY
11	584.14.025.000/30	BLINKER KPL. VO.LI./HI.RE. '99 SCHWARZ	FLASHER CPL.FRONT L/S REAR R/S BLACK	2
12	584.14.026.000/30	BLINKER KPL. VO.RE./HI.LI. '99 SCHWARZ	FLASHER CPL.FRONT R/S REAR L/S BLACK	2
13	584.14.028.000	LEUCHTHAUBE LINKS & RECHTS '98	FLASHER LENS L/S & R/S '98	4
14	441.11.015.100	LAMPE 12V 10W (BA15S)	BULB 12V 10W (BA15S)	4
16	0125 100003	UNTERLEGSCHIBE DIN0125-A10,5	WASHER DIN0125-A10,5	4
17	0797 100003	ZAHNSCHIBE DIN6797-J10,5 ZI	LOCK WASHER DIN6797-J10,5 ZI	4
18	584.14.030.000	SK-BUNDMUTTER M10X1,25 SW=13	HH COLLAR NUT M10X1,25 WS=13	4
40	503.14.040.100	RÜCKLICHT KPL. 125-380 EGS '98	REAR LIGHT CPL.125-380 EGS '98	1
41	503.14.041.100	LEUCHTHAUBE 125-380 EGS '98	REAR LIGHT LENS 125-380 EGS'98	1
42	584.14.042.000	LAMPE 12V 21/5W (BAY15S)VERST.	BULB 12V 21/5W (BA15S)REINFOR.	1
52	503.11.076.000	KABELSTR.HINTERTEIL 125-380'98	WIRING HARNESS REAR 125-380'98	1
60	502.11.510.000	SCHEINWERFER KPL. CEV 394 '93	HEADLIGHT CPL. CEV 394 '93	1
62	584.14.010.000	SCHEINWERFERHALTERUNG '98	HEAD LIGHT SUPPORT '98	2
64	571.11.038.000	LAMPE H4 12V 60/55W (P43T)	BULB H4 12V 60/55W (P43T)	1
65	490.11.436.000	LAMPENHALTER	BULB HOLDER	1
66	502.11.537.000	GUMMIKAPPE	RUBBER CAP	1
68	0797 060003	ZAHNSCHIBE DIN6797-J 6,4	TOOTH LOCK WASH. DIN6797-A 6,4	2
69	0933 060203	SK.SCHRAUBE DIN0933-M 6X20	HH SCREW DIN0933-M 6X20	2
70	490.11.435.000	LAMPE 12V 5W (W2,1X9,5D)	BULB 12V 5W (W2,1X9,5D)	1
71	0016 040183	KUNSTSTOFFSCHR. KB40X18 WN1412	PLASTIC SCREW KB40X18 WN1412	4
73	502.11.510.010	KABEL FÜR SCHEINWERFER '93	CABLE FOR HEADLIGHT '93	1

FIG	TEILNR/PARTNR	BEZEICHNUNG	DESCRIPTION	QTY
1	503.14.057.000	TACHOMETER FACOMSA 180 KMH '99	SPEEDOMETER FACOMSA 180 KMH'99	1
2	503.14.065.100	TACHOGEHÄUSE 125-380 EGS '99	SPEEDOMETER CASE 125-380 EGS	1
3	503.11.065.000	ZÜND-UND LENKSCHLOSS KPL. ZADI	IGNITION LOCK CPL. ZADI '99	1
5*	580.11.025.000	ÖLSTANDKONTROLLEUCHTE ROT EXE	OIL LEVEL LIGHT RED EXE	1
7	503.14.057.050	MUTTER FÜR TACHOMET. M12 SW=17	NUT FOR SPEEDOM. M12 SW=17	1
8	310.08.060.000	KABELTÜLLE D=8MM OFFEN	RUBBER SLEEVE D=8MM OPEN	2
9	491.11.425.000	LAMPE 12V 1,2W W2X4,6D	BULB 12V 1,2W (W2X4,6D)	3
10	0016 050121	KUNSTSTOFFSCHR. KA50X12 PT1411 SCHWARZ	PLASTIC SCREW KA50X12 PT1411 BLACK	2
15	503.14.061.000	TACHOHALTERUNG 125-380 EGS '99	SPEEDOM.BRACKET 125-380 EGS'99	1
17	0014 060103	SK.BUNDSCHRAUBE M 6X10 SW=8	HH COLLAR SCREW M 6X10 WS=8	2
20*	512.14.055.000	TACHOWELLE L=885MM 125EXE 2000	SPEEDO.CABLE 885MM 125EXE 2000	1
21	503.14.050.100	TACHOANTRIEB 748233 (2.66) 17"	SPEEDOMETER DRIVE 748233(2.66)	1
21	503.14.050.000	TACHOANTRIEB 748220 (3.0) 2000	SPEEDOMETER DRIVE 748220 (3.0)	1
23	503.14.053.000	MITNEHMER F. TACHOANTRIEB 2000	DRIV.DOG F.SPEEDOM.DRIVE 2000	1



3



20

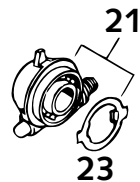

21

23

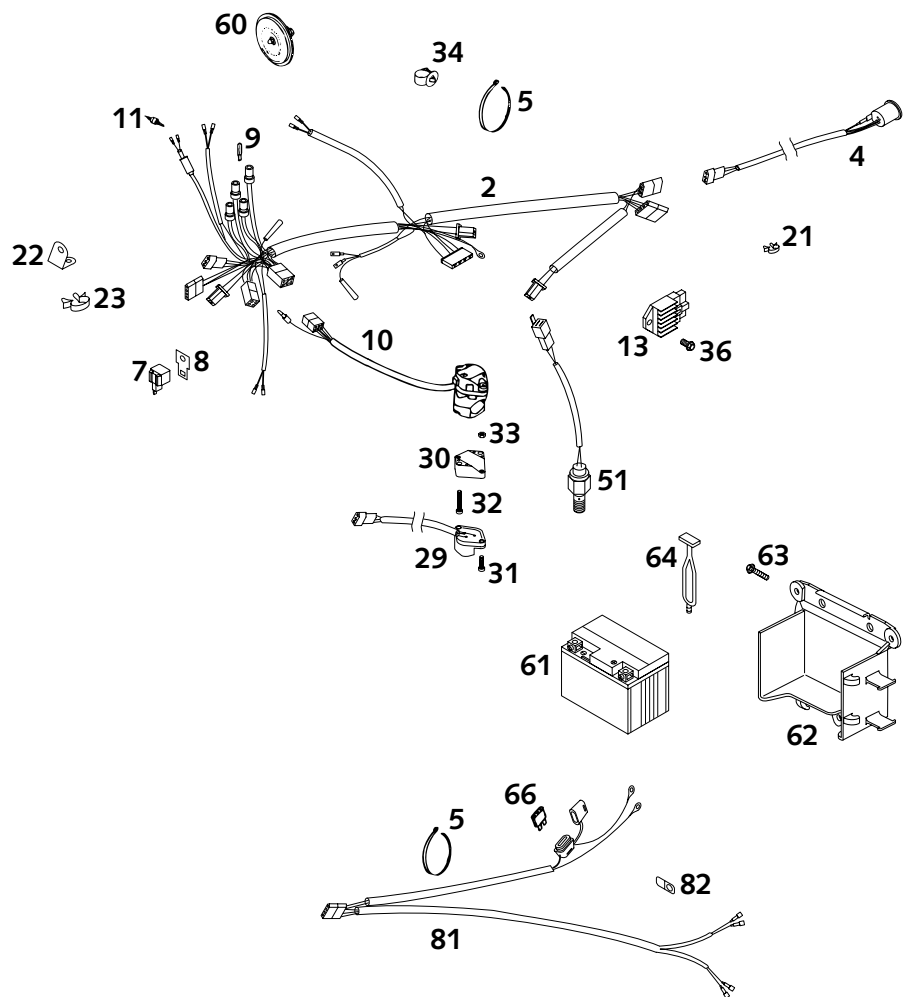

FIG	TEILNR/PARTNR	BEZEICHNUNG	DESCRIPTION	QTY
2*	512.11.075.000	KABELSTRANG KPL. 125 EXE 2000	WIRING HARN. KPL. 125 EXE 2000	1
4	503.11.076.000	KABELSTR.HINTERTEIL 125-380'98	WIRING HARNESS REAR 125-380'98	1
5	440.11.076.200	KABELBAND 200MM	CABLE TIE 200MM	X
-	440.11.076.305	KABELBAND 290MM	CABLE TIE 290MM	1
7	446.11.207.200	BLINKGEBER SUMITOMO ADV.'97	FLASHER UNIT SUMITOMO ADV.'97	1
8	582.11.031.100	HALTEBLECH FÜR BLINKRELAIS	BRACKET FOR FLASHER RELAY	1
9	491.11.425.000	LAMPE 12V 1,2W W2X4,6D	BULB 12V 1,2W (W2X4,6D)	4
10	503.11.070.000	LICHTSCHALTER CEV 2/4TAKT '98 SYMBOLE WEISS	H.LIGHT SWITCH CEV 2/4TAKT '98 SYMBOLS WHITE	1
11	510.11.050.000	BREMSLICHTSCHALTER VORNE	FRONT BRAKE LIGHT SWITCH	1
13	503.11.034.000	SPANNUNGSREGLER 12V 125-380'98	VOLTAGE REGULA. 12V 125-200'98	1
21	570.13.072.000	KABELHALTER 12MM 0210	WIRING HOLDER 12MM 0210	X
-	570.13.072.100	KABELHALTER 16MM	WIRING HOLDER 16MM	X
22	546.11.090.000	HALTEBLECH FÜR BATTERIE '97	RETAINING PLATE FOR BATTERY'97	1
23*	570.13.072.200	KABELHALTER 18MM	WIRING HOLDER 18MM	1
29	503.11.029.000	BLINKERSCHALTER CEV '98	FLASHER SWITCH CEV '98	1
30	130.11.070.060	ADAPTER FÜR BLINKERSCHALTER'98	ADAPTER FOR FLASHER SWITCH '98	1
31	0985 040163	LINSENSCHRAUBE DIN7985-M 4X16	FLAT HEAD SCREW DIN7985-M 4X16	2
32	0084 040223	ZYL.SCHRAUBE DIN0084-M 4X22 A	CYL.HEAD SCREW DIN0084-M 4X22A	2
33	0934 040003	SK.MUTTER DIN0934-M 4	HEXAGON NUT DIN0934-M 4	2
34	581.11.076.000	KABELHALTER KHS NR. 150-47610	CABLE SUPPORT KHS NR.150-47610	1
36	0015 060123	SK.BUNDSCHRAUBE M 6X12 SW=8	HH COLLAR SCREW M 6X12 WS=8	1
51	503.11.051.100	BREMSLICHTSCHALTER HINTEN '98	BRAKE LIGHT SWITCH REAR '98	1
60	545.11.060.100	GLEICHSTROMHORN 12V NIKKO	DC HORN 12V NIKKO	1
61	511.11.008.000	BATTERIE 12V 3AH YUASA	BATTERY 12V 3AH YUASA	1
62	590.11.055.000	BATTERIEFACH KUNSTSTOFF SCHW.	BATTERY CARRIER PLASTIC BLACK	1
63	0017 060203	SONDERSCHRAUBE T60 6X20	SPECIAL SCREW T60 6X20	3
64	503.03.025.000	GUMMI FÜR SEITENSTÄNDER '98	RUBBER FOR SIDE STAND '98	2
66	580.11.109.110	STECKSICHERUNG 10 A 2000	FUSE 10 A 2000	1
81*	512.11.081.000	BLINKERKABELSTR.HI.125EXE 2000	FLASH.WIRINGHARN.REAR EXE 2000	1
82	500.31.003.000	HALTEPLÄTTCHEN	RETAINING PLATE	2

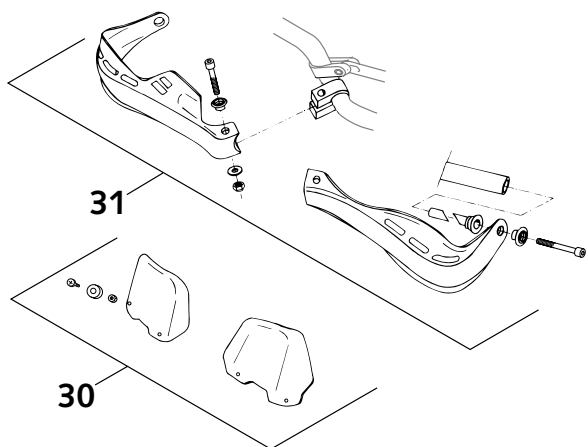
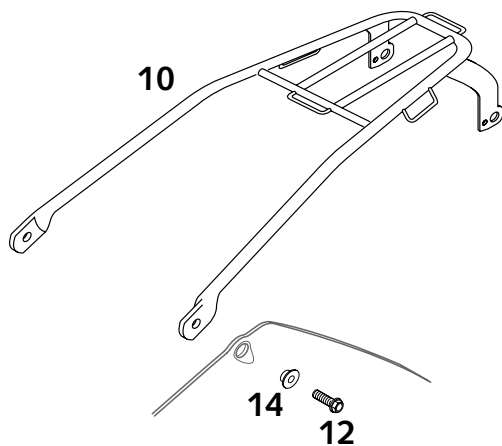

FIG	TEILNR/PARTNR	BEZEICHNUNG	DESCRIPTION	QTY
10*	512.12.010.000	GEPÄCKTRÄG.SILBER 125 EXE 2000	BAGGAGE CAR.SILVER 125EXE 2000	1
12	0015 060203	SK.BUNDSCHRAUBE M 6X20 SW=8	HH COLLAR SCREW M 6X20 WS=8	2
14	503.08.052.000	BÜCHSE FÜR SPOILER 6X11X16X5	BUSH FOR SPOILER 6X11X16X5	2
30	502.02.079.050/30	WINDSCHUTZ LI.& RE.KPL.SCHWARZ	SCREEN CPL.L+R/S BLACK	1
31	502.02.079.044/30	HANDSCHUTZ LI&RE.KPL. SCHWARZ	HAND GUARD CPL.L+R/S BLACK	1





# TECHNISCHE DATEN FAHRGESTELL 125 EXE / 125 SUPERMOTO 2000

	<b>125 EXE</b>	<b>125 SUPERMOTO</b>
Rahmen	Zentralrohrrahmen aus Chrom-Molybdän-Stahlrohren	
Gabel	Telegabel <b>White Power – Up Side Down</b> 40 TA	
Federweg vorne/hinten	220 mm / 260 mm	
Hinterradfederung	WP <b>Progressive Damping System</b> Federbein, Alu-Hinterradschwinge	
Bremse vorne	Scheibenbremse mit gelochter Bremsscheibe, Bremsattel schwimmend gelagert	
Bremsscheibe vorne	Ø 260mm	Ø 320 mm
Bremse hinten	Scheibenbremse mit gelochter Bremsscheibe Ø 220 mm, Bremsattel schwimmend gelagert	
Bremsscheiben	Verschleiß max. 0,40 mm	
Bereifung vorne	3.00 - 21"	110/70 - 17"
Luftdruck solo	1,8 bar	1,8 bar
Luftdruck Sozius	2,0 bar	2,0 bar
Bereifung hinten	4.60 - 18"	130/70 - 17"
Luftdruck solo	2,0 bar	2,1 bar
Luftdruck Sozius	2,2 bar	2,3 bar
Tankinhalt	11 Liter	
Übersetzung Hinterrad	14:40 Z	14:38 Z
Kette	O-Ring 5/8 x 1/4 "	
Batterie	wartungsfrei 12V 3Ah	
Lampenbestückung	Scheinwerfer H4 12V 60/55W (Sockel P43t)	
	Begrenzungslicht 12V 5W (Sockel W2,1x9,5d)	
	Instrumentenbeleuchtung 12V 2W (Sockel W2x4,6d)	
	Brems- Rücklicht 12V 21/5W (Sockel BaY15d)	
	Blinker 12V 10W (Sockel Ba15s)	
Steuerkopfwinkel	63°	
Radstand	1461 ± 10 mm	
Sitzhöhe unbelastet	ca. 865 mm	ca. 830mm
Bodenfreiheit unbelastet	ca. 290 mm	ca. 255 mm
Leergewicht *	104 kg	
höchstzul. Achslast vorne	145 kg	
höchstzul. Achslast hinten	190 kg	
höchstzul. Gesamtgewicht	335 kg	

\* Leergewicht ohne Kraftstoff

## STANDARD-EINSTELLUNG – GABEL

	<b>WP 06181777A</b>
Druckstufendämpfung	10
Zugstufendämpfung	9
Feder	4,2 N/mm
Federvorspannung	10 mm
Luftkammerlänge	140 mm
Füllmenge pro Gabelholm	ca. 500 ccm
Gabelöl	SAE 5

## STANDARD-EINSTELLUNG – FEDERBEIN

	<b>WP 121817715</b>
Druckstufendämpfung	3
Zugstufendämpfung	14
Feder	PDS1 -250
Federvorspannung	5 mm

## ANZUGSDREHMOMENTE – FAHRGESTELL

Bundmutter Steckachse vorne	M 16x1,5	40 Nm
Bremszange vorne	M 8	25 Nm + Loctite 243
Klemmschrauben Gabelbrücke oben	M 8	20 Nm
Klemmschrauben Gabelbrücke unten	M 8	15 Nm
Klemmschrauben Gabelfaust	M 8	10 Nm
Bundmutter Steckachse hinten	M 20x1,5	80 Nm
Sechskantmutter Schwinggarnbolzen	M 14x1,5	100 Nm
Bundschraube Lenkerklemmbrücke	M 8	20 Nm
Innensechskantschraube Lenkeraufnahme	M 10	40 Nm
Federbein oben	M 12	60 Nm + Loctite 243
Federbein unten	M 12	60 Nm
Schraube Einstellung Federvorspannung Federbein	M 6	8 Nm
Restliche Schrauben am Fahrgestell	M 6 M 8 M 10	10 Nm 25 Nm 45 Nm

# TECHNICAL SPECIFICATIONS CHASSIS 125 EXE / 125 SUPERMOTO 2000

	<b>125 EXE</b>	<b>125 SUPERMOTO</b>
Frame	Central chrome-moly-steel frame	
Fork	White Power – Up Side Down 40 TA	
Wheel travel front/rear	220/260 mm (8.7/10.2 in)	
Rear suspension	WP Progressive Damping System shock absorber, aluminium swingarm	
Front brake	Disc brake with carbon-steel brake disc, brake caliper floated	
Front brake disc	Ø 260 mm (10.2 in)	Ø 320 mm (12.6 in)
Rear brake	Disc brake with carbon-steel brake disc Ø 220 mm (8.7 in), brake caliper floated	
Brake discs	Wear limit max. 0,4 mm (0,016 in)	
Front tires	3.00 - 21"	110/70 - 17"
Air pressure, driver only	1,8 bar (26 psi)	1,8 bar (26 psi)
Air pressure, driver plus passenger	2,0 bar (29 psi)	2,0 bar (29 psi)
Rear tires	4.60 - 18"	130/70 - 17"
Air pressure, driver only	2,0 bar (29 psi)	2,1 bar (30 psi)
Air pressure, driver plus passenger	2,2 bar (32 psi)	2,3 bar (33 psi)
Fuel tank capacity	11,0 liter (3 US Gallons)	
Final drive ratio	14:40 t	14:38 t
Chain	O-ring 5/8 x 1/4 "	
Battery	maintenance free 12V 3Ah	
Lamps	head light parking light cockpit light stop and tail light flasher	H4 12V 60/55W (socket P43t) 12V 5W (socket W2,1x9,5d) 12V 2W (socket W2x4,6d) 12V 21/5W (socket BaY15d) 12V 10W (socket Ba15s)
Steering head angle	63°	
Wheel base	1461 ± 10 mm (57,5 ± 0,4 in)	830 mm (32,7 in)
Seat height, unloaded	865 mm (34,0 in)	255 mm (10,0 in)
Ground clearance, unloaded	290 mm (11,4 in)	
Dead-weight *	104 kg (230 lbs)	
Max. permissible front axle load	145 kg (320 lbs)	
Max. permissible rear axle load	190 kg (419 lbs)	
Max. permissible laden weight	335 kg (740 lbs)	

\* Dead-weight without fuel

STANDARD ADJUSTMENT - FORK	
Compression adjuster	WP 06181777A
Rebound adjuster	10
Spring	9
Spring preload	4,2 N/mm
Air chamber length	10 mm (0.4 in)
Capacity per fork leg	140 mm (5.5 in)
Fork oil	approx. 500 ccm SAE 5

STANDARD ADJUSTMENT - SHOCK ABSORBER	
Compression adjuster	WP 12181715
Rebound adjuster	3
Spring	14
Spring preload	PDS1-250 5 mm (0.2 in)

TIGHTENING TORQUES - CHASSIS			
Collar nut front wheel spindle	M 16x1,5	40 Nm (30 ft.lb)	
Brake caliper front	M 8	25 Nm (19 ft.lb)	+Loctite 243
Clamping screws upper fork bridge	M 8	20 Nm (15 ft.lb)	
Clamping screws lower fork bridge	M 8	15 Nm (11 ft.lb)	
Clamping screws fork stubs	M 8	10 Nm (7 ft.lb)	
Collar nut rear wheel spindle	M 20x1.5	80 Nm (59 ft.lb)	
Hexagon nut swing arm bolt	M 14x1.5	100 Nm (74 ft.lb)	
Collar screw handlebar clamp	M 8	20 Nm (15 ft.lb)	
Allen head screw handlebar support	M 10	40 Nm (30 ft.lb)	+Loctite 243
Shock absorber top	M 12	60 Nm (44 ft.lb)	
Shock absorber bottom	M 12	60 Nm (44 ft.lb)	
Screw adjusting ring spring preload	M 6	8 Nm (6 ft.lb)	
Other screws on chassis	M 6 M 8 M 10	10 Nm (7 ft.lb) 25 Nm (19 ft.lb) 45 Nm (33 ft.lb)	

- = Ausführung durch KTM Fachwerkstätte
- = Ausführung durch den Kunden oder Zusatzauftrag für KTM

Ölstand im Öltank prüfen und Entlüftungsschlauch auf knickfreie Verlegung prüfen	<input type="radio"/>	Vor jeder Inbetriebnahme	<input type="radio"/>	nach jeder Reinigung	<input type="radio"/>	1. Service nach 1000 km	<input checked="" type="radio"/>	<input type="radio"/>	2. Service bei 4000 km	<input type="radio"/>	<input checked="" type="radio"/>	nach 4000 km oder 1x jährlich	<input type="radio"/>	nach 20 000 km oder nach 2 Jahren
Getriebeöl wechseln							●	●	●	●				
Zündkerze prüfen, wenn nötig erneuern, Elektrodenabstand einstellen								●		●				
Ansaugflansch auf Risse prüfen												●		
Schwimmerkammer des Vergasers entleeren – reinigen				○						●	●	●	●	
Leeraufstellung und Abgaswerte bei warmem Motor prüfen							●	●	●	●	●	●		
Belüftungsschläuche von Vergaser und Getriebe auf knickfreie Verlegung prüfen							●	●	●	●	●	●		
Luftfilter, Filterkasten und Vergasermanschette reinigen *				○						○	●	●		
Kettenräder, Kettenführungen, Kettengleitschutz und Kette prüfen							○	○	○	○	○	○		
Kette reinigen und ölen *							○	○	○	○	○	○		
Kettenspannung prüfen				○			○	○	○	○	○	○		
Kühlfüssigkeitsstand prüfen				○			○	○	○	○	○	○		
Kühlschutz prüfen				○			○	○	○	○	○	○		
Kühlsystem auf Dichtheit prüfen – Sichtprüfung				○			○	○	○	○	○	○		
Kühlfüssigkeit wechseln													●	
Auspuffanlage auf Dichtheit prüfen							●	●	●	●	●	●		
Glasfasergarn-Füllung des Schalldämpfers tauschen													●	
Silentblöcke der Auspuffanlage prüfen										●	●	●		
Bremsflüssigkeitsstand in den Vorratsbehältern prüfen				○			○	○	○	○	○	○		
Bremsflüssigkeit wechseln													●	
Belagstärke der Bremsklötze prüfen				○			○	○	○	○	○	○		
Bremsscheiben auf Verschleiss und Beschädigung prüfen										○	○	○	○	
Zustand und Verlegung der Bremschläuche prüfen				○			○	○	○	○	○	○		
Leerweg und Leichtgängigkeit von Hand- und Fußbremshebel prüfen				○			○	○	○	○	○	○		
Ölstand im Geberzylinder der hydraulischen Kupplung prüfen							●	●	●	●	●	●		
Öl der hydraulischen Kupplung wechseln													●	
Telegabel auf Funktion und Dichtheit prüfen				○			○	○	○	○	○	○		
Staubmanschetten der Telegabel reinigen *							○	○	○	○	○	○		
Entlüftungsschrauben an den Gabelbeinen lösen							○	○	○	○	○	○		
Telegabel vollständig warten													●	
Steuerkopflagerung auf Spiel prüfen							●	●	●	●	●	●		
Steuerkopflager und deren Dichtungselemente reinigen und fetten													●	
Federbein auf Funktion und Dichtheit prüfen				○			○	○	○	○	○	○		
Schwingarmlagerung schmieren													●	
Speichenspannung und Felgenschlag prüfen *							●	○	○	○	○	○		
Radlager auf Spiel prüfen							●	●	●	●	●	●		
Reifenzustand und Reifenluftdruck prüfen				○			○	○	○	○	○	○		
Seilzüge auf Leichtgängigkeit prüfen				○			○	○	○	○	○	○		
Seilzüge auf Beschädigung prüfen, einstellen und ölen *							○	○	○	○	○	○		
Elektrische Anlage bei laufendem Motor prüfen				○			○	○	○	○	○	○		
Batterierhaltung und Anschlüsse prüfen							●	●	●	●	●	●		
Scheinwerferreinigung prüfen							●	●	●	●	●	●		
Zündschloß und Lichtschalter mit Kontaktspray einsprühen							○	○	○	○	○	○		
Mittelständer ölen und auf Funktion prüfen							○	○	○	○	○	○		
Für Sicherheit und Funktion wichtige Schraubverbindungen auf festen Sitz prüfen							●	●	●	●	●	●		
Alle nicht abgedichteten Gleit- und Lagerstellen nach Bedarf ölen bzw. fetten *				○			○	○	○	○	○	○		

\* NACH GELÄNDEINSATZ ÜBERPRÜFEN GEGEBENFALLS WARTEN

125 EXE / Supermoto 2. 2000

- = to be carried out by a KTM dealer
- = can be carried out by the rider or alternatively by a KTM dealer whereby the rider carries the costs thereof

	before each start	after washing	1st service, after 1000 km (600 miles)	2nd service at 4000 km (2500 miles)	after 4000 km (2500 miles) or once a year	after 20000 km (12500 miles) or after 2 years
Check oil level in oil tank and vent hose for kink-free arrangement	<input type="radio"/>		<input type="radio"/>	<input type="radio"/>	<input type="radio"/>	<input type="radio"/>
Change gear oil			●	●	●	
Check spark plug and, if necessary, replace it, adjust electrode gap				●	●	
Check intake flange for cracks					●	
Drain float chamber of carburetor - clean it		<input type="radio"/>		●	●	
Check idle setting and emission values with warm engine			●	●	●	
Check ventilation hoses of carburetor and gear box for kink-free arrangement				●	●	
Clean air filter, filter box, and carburetor connection boot *		<input type="radio"/>		●	●	
Check chain wheels, chain sliding components, chain guides, and chain	<input type="radio"/>		<input type="radio"/>	●	●	
Clean and oil chain *		<input type="radio"/>	<input type="radio"/>	<input type="radio"/>	<input type="radio"/>	
Check chain tension	<input type="radio"/>		●	●	●	
Check coolant level	<input type="radio"/>		●	●	●	
Check antifreeze				●	●	
Check cooling system for leaks - sight inspection	<input type="radio"/>		●	●	●	
Change coolant					●	●
Check exhaust system for leaks			●	●	●	
Change glass fiber yarn packing of muffler						●
Check silentblocks of exhaust suspension			●	●	●	
Check brake-fluid level in reservoirs	<input type="radio"/>		●	●	●	
Change brake fluid					●	
Check lining thickness of brake pads	<input type="radio"/>			●	●	
Check brake discs for wear and damage				●	●	
Check state and arrangement of brake hoses	<input type="radio"/>		<input type="radio"/>	●	●	
Check handbrake and footbrake levers for backlash and smooth operation	<input type="radio"/>		●	●	●	
Check oil level in master cylinder of hydraulic clutch			●	●	●	
Change oil of hydraulic clutch						●
Check telescopic fork for function and tightness	<input type="radio"/>		<input type="radio"/>	<input type="radio"/>	●	
Clean dust-protection sleeves of telescopic fork *		<input type="radio"/>		<input type="radio"/>	<input type="radio"/>	
Loosen bleeder screws on fork legs			<input type="radio"/>	<input type="radio"/>	<input type="radio"/>	
Perform a full maintenance job for the telescopic fork						●
Check steering head bearing system for play			●	●	●	
Clean and grease steering head bearings and their sealing elements				●	●	●
Check shock absorber for its function and tightness	<input type="radio"/>		<input type="radio"/>	●	●	
Lubricate swing arm bearing system						●
Check for spoke tension and rim runout *			●	<input type="radio"/>	●	
Check wheel bearings for play			●	●	●	
Check tire condition and air pressure	<input type="radio"/>		●	●	●	
Check cables for smooth operation	<input type="radio"/>					
Check cables for damage, adjust and oil them *		<input type="radio"/>		●	●	●
Check electrical system with running engine	<input type="radio"/>		●	●	●	
Check battery holder and connections				●	●	
Check headlight adjustment			●	●	●	
Apply contact spray to ignition lock and light switch		<input type="radio"/>			●	
Oil center stand and check its function		<input type="radio"/>	<input type="radio"/>	●	●	
Check that all the necessary screws are tightly fitted to ensure operation and safety			●	●	●	
Oil or grease all non-sealed sliding and bearing points as necessary *	<input type="radio"/>	<input type="radio"/>	<input type="radio"/>	<input type="radio"/>	<input type="radio"/>	

\* CHECK AFTER RIDING OFF-ROAD AND IF NECESSARY CARRY OUT MAINTENANCE.



NOTIZEN

NOTE





KTM SPORTMOTORCYCLE AG  
5230 Mattighofen  
Austria  
Internet: [www.ktm.at](http://www.ktm.at)

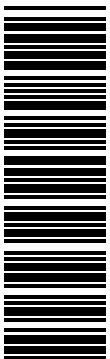

320811