

400/520 SX MXC EXC RACING

KTM
SPORTMOTORCYCLES

ERSATZTEILKATALOG
MOTOR
SPARE PARTS MANUAL
ENGINE

2001

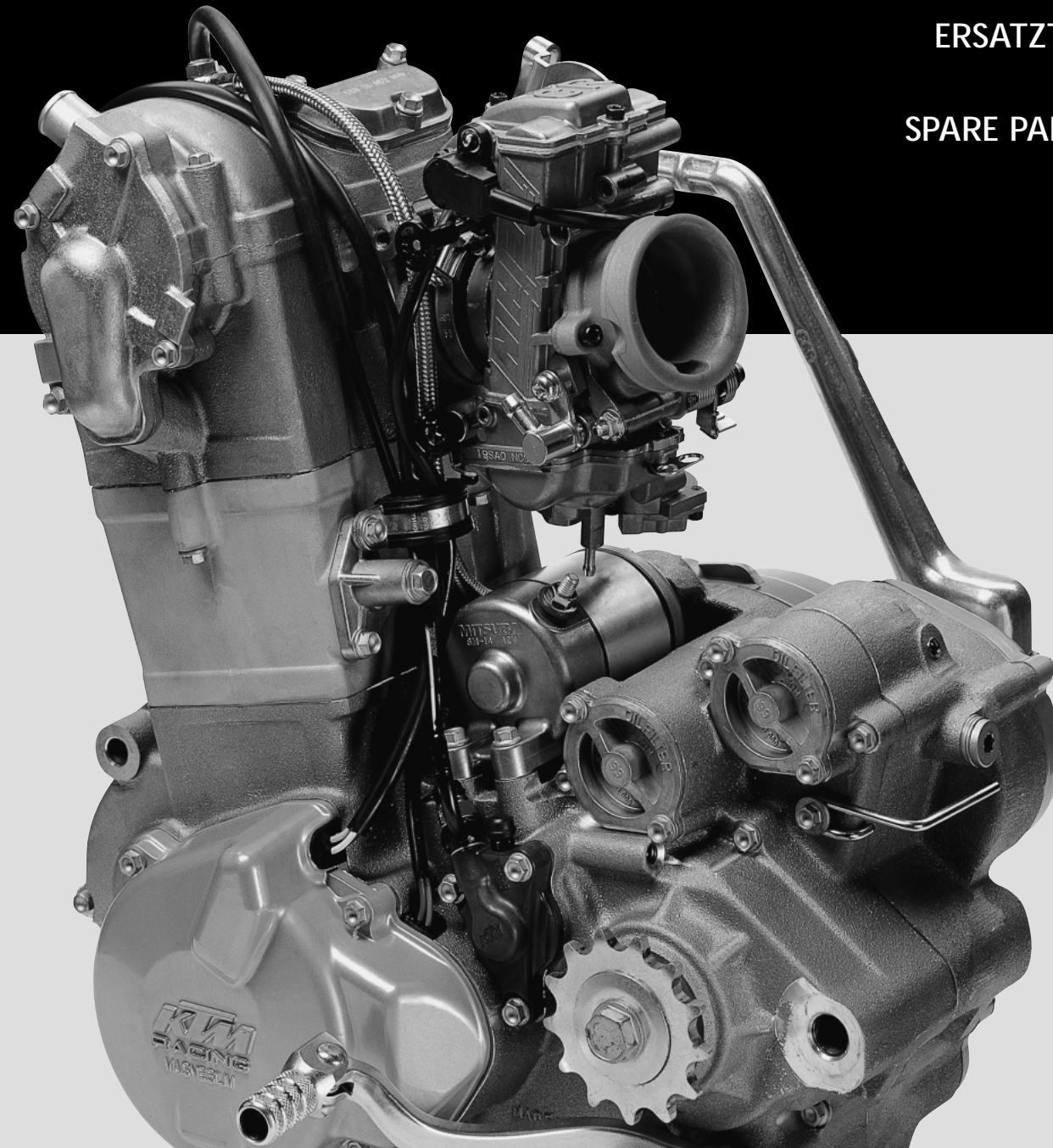

MOTORGEHÄUSE
ENGINE CASE

+ 2x0625 160040
0625 062054
2x0625 062034
490.30.023.000
2x546.32.095.000
2x0625 618050

SEITE
Page
3

KURBELWELLE, KOLBEN
CRANKSHAFT, PISTON

SEITE
Page
5

AUSGLEICHSWELLE
BALANCER SHAFT

SEITE
Page
6

ZYLINDER
CYLINDER

SEITE
Page
7

ZYLINDERKOPF
CYLINDER HEAD

SEITE
Page
8

VENTILTRIEB
VALVE DRIVE

SEITE
Page
9

STEUERTRIEB
TIMING VALVE

SEITE
Page
10

SCHMIERSYSTEM
LUBRICATING SYSTEM

SEITE
Page
11

VERGASER KEIHIN MX-FCR39
CARBURATOR KEIHIN MX-FCR39

SEITE
Page
12

ZÜNDANLAGE KOKUSAN 4K3A
IGNITION SYSTEM KOKUSAN 4K3A

SEITE
Page
13

ZÜNDANLAGE KOKUSAN 4K3B
IGNITION SYSTEM KOKUSAN 4K3B

SEITE
Page
14

ELEKTROSTARTER
ELECTRIC STARTER

SEITE
Page
15

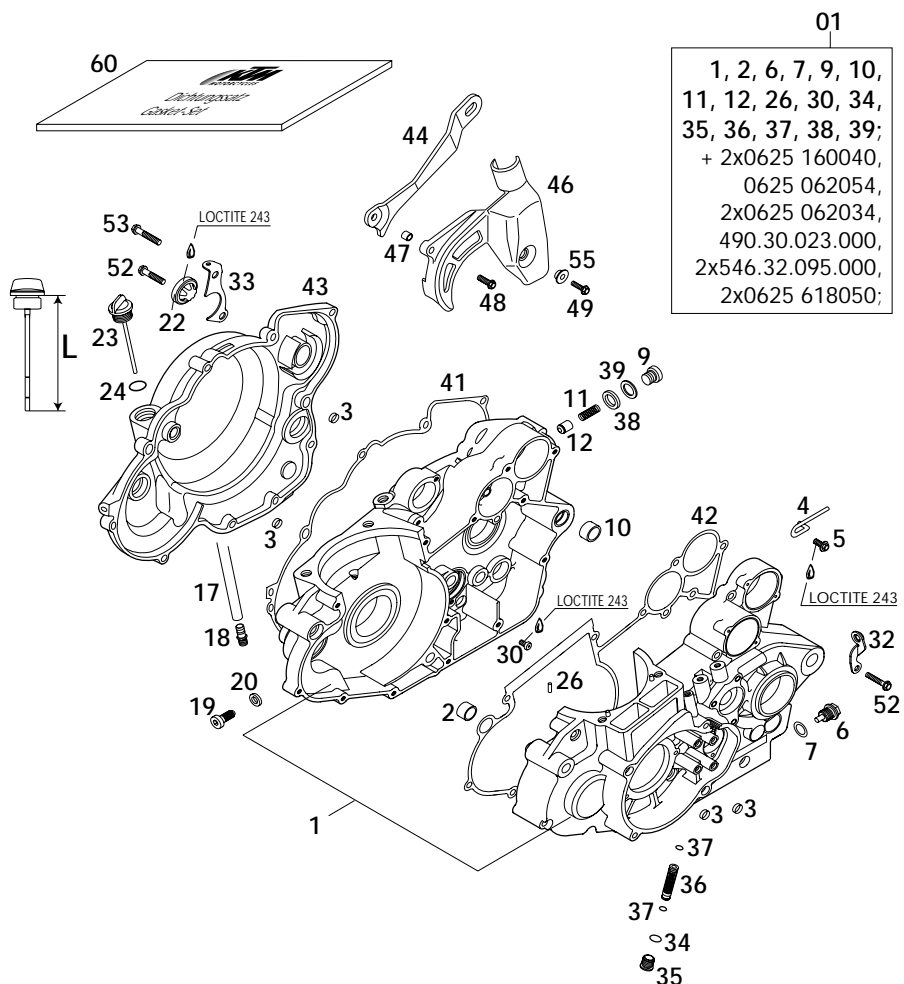

FIG	TEILNR/PARTNR	BEZEICHNUNG	DESCRIPTION	QTY
01	590.30.000.044	MOTERGEH. KPL.M.GETR.LAG. 2000	ENGINE CASE CPL.W.TR.BEAR.2000	1
2	510.30.026.100	PASSHÜLSE 17 X14 X12	DOWEL 17 X14 X12	1
3	490.30.090.000	PASSHÜLSE 9,8 X 7 X 10	DOWEL 9,8 X 7 X 10	4
4	590.30.090.000	BÜGEL FÜR ENTLÜFTUNGSSCHLAUCH	HANGER FOR VENT HOSE	1
5	0014 060153	SK.BUNDSCHRAUBE M 6X15 SW=8	HH COLLAR SCREW M 6X15 WS=8	1
6	580.30.021.000	ÖLABLASSCHR.B.M.MAGNET M12X1,5	OILDRAIN PLUG W.MAGNET M12X1,5	1
7	580.38.022.000	CU-DICHTRING DIN7603-12X18X1,5	CU-SEAL RING DIN7603-12X18X1,5	1
9	0908 120153	VERSCHL.SCHR. DIN0908-M12X1,5	PLUG DIN0908-M12X1,5	1
10	501.30.027.000	PASSHÜLSE 19 X15,1X12	DOWEL 19 X15,1X12	1
11	580.38.023.300	DRUCKFEDER L=25MM D=1MM	PRESSURE SPRING L=25MM D=1MM	1
12	580.38.028.000	VENTILKOLBEN D=10MM	VALVE PISTON D=10MM	1
17	590.31.050.000	SCHLAUCH MOTORENTLÜFTUNG 0,71M	TUBE ENGINE BREATHER 0,71M	1
18	590.30.022.100	ENTLÜFT.STUTZEN M12X1,5 SW=13	BLEEDER FLANGE M12X1,5 WS=13	1
19	580.30.080.000	FIXIERSCHRAUBE M8	LOCATING SCREW M8	1
20	580.30.081.000	CU-DICHTRING 8 X 14 X 3	CU-SEAL RING 8 X 14 X 3	1
22	590.30.019.000	ÖLSCHAUGLAS G 1777 Y	OIL LEVEL VIEWER G 1777 Y	1
23	590.30.020.044	ÖLMESSTAB KPL. L=102MM 2000	OIL DIPSTICK CPL. L=102MM 2000	1
24	0770 191015	O-RING 19,00X3,00 NBR	O-RING 19,00X3,00 NBR	1
26	0402 040980	NADELROLLE DIN5402 NRB 4X 9,8	NEEDLE ROL.DIN5402 NRB 4X 9,8	2
30	0985 050083	LINSENSCHRAUBE DIN7985-M 5X 8	FLAT HEAD SCREW DIN7985-M 5X 8	1
32	590.13.068.000	HALBLECH BREMSFLÜS.RESERVOIR	BRACKET BRAKE FLUID RESERVOIR	1
33	590.30.001.090	HALTEBL. FÜR BREMSHEBELFEDER	RET.BRACKET F.BRAKE LEVER HUB	1
34*	0770 120020	O-RING 12,00X2,00 NBR 70	O-RING 2X12	1
35	590.38.014.000	VERSCHLUSSSCHRAUBE M16X1,5	PLUG M16X1,5	1
36	590.38.015.000	ÖLSIEB 11,8X44,5MM	OIL SCREEN 11,8X44,5MM	1
37	0770 090015	O-RING 9X1,5 NBR	O-RING 9X1,5 NBR	2
38	0603 121830	CU-DICHTRING DIN7603 12X18X3	SEAL RING DIN7603 12X18X3	1
39	580.38.022.000	CU-DICHTRING DIN7603-12X18X1,5	CU-SEAL RING DIN7603-12X18X1,5	1
41	590.30.025.000	KUPPLUNGSDECKELDICHTUNG 0,5MM	CLUTCH COVER GASKET 0,5MM	1
42	590.30.039.000	MOTERGEHÄUSEDICHTUNG	ENGINE CASE GASKET	1
43	590.30.001.000	KUPPLUNGSDECKEL RACING 2000	CLUTCH COVER RACING 2000	1
44	590.30.047.000	KETTENDÄMPFUNGSBLECH RAC. 2000	CHAIN DAMPERSHEET RACING 2000	1
46	590.30.060.000	KETTENRITZELABDECK.RACING 2000	SPROCKET COVER RACING 2000	1
47	546.13.038.150	BÜCHSE 6,5X8X11	BUSHING 6,5X8X11	1
48	0015 060403	SK.BUNDSCHRAUBE M 6X40 SW=8	HH COLLAR SCREW M 6X40 WS=8	1
49	0015 060203	SK.BUNDSCHRAUBE M 6X20 SW=8	HH COLLAR SCREW M 6X20 WS=8	1

* = NEUTEIL / NEW PART X = NACH BEDARF / AS REQUIRED

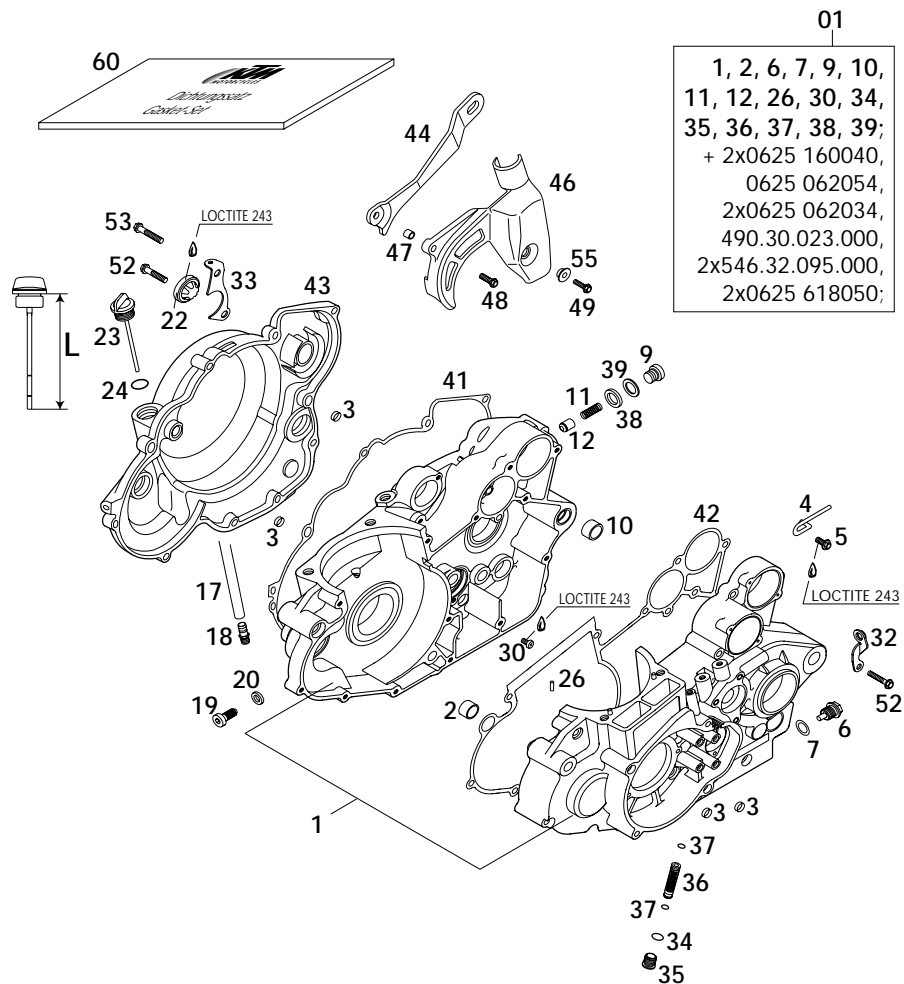
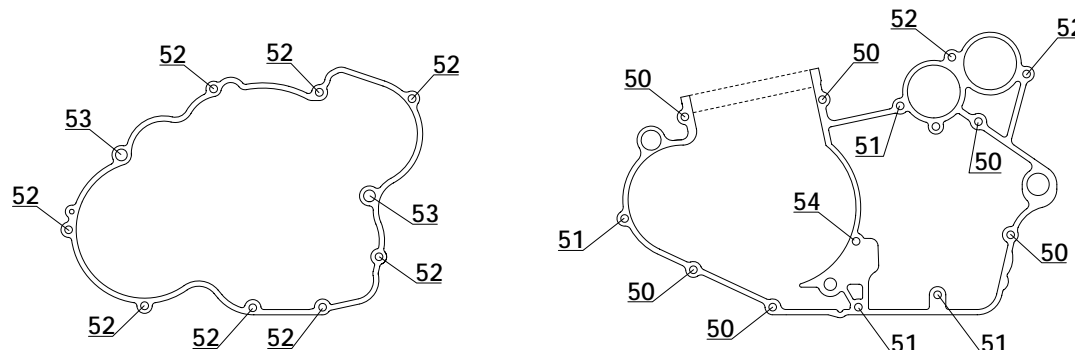

FIG	TEILNR/PARTNR	BEZEICHNUNG	DESCRIPTION	QTY
50	0015 060453	SK.BUNDSCHRAUBE M 6X45 SW=8	HH COLLAR SCREW M 6X45 WS=8	6
51	0015 060603	SK.BUNDSCHRAUBE M 6X60 SW=8	HH COLLAR SCREW M 6X60 WS=8	4
52	0015 060303	SK.BUNDSCHRAUBE M 6X30 SW=8	HH COLLAR SCREW M 6X30 WS=8	12
53	0015 060353	SK.BUNDSCHRAUBE M 6X35 SW=8	HH COLLAR SCREW M 6X35 WS=8	3
54	0015 060753	SK.BUNDSCHRAUBE M 6X75 SW=8	HH COLLAR SCREW M 6X75 WS=8	1
55	503.08.053.000	BÜCHSE FÜR SPOILER 6X11X16X7,5	BUSH FOR SPOILER 6X11X16X7,5	1
60	590.30.099.000	DICHTUNGSSATZ KPL. RACING 2000	GASKET SET CPL. RACING 2000	1



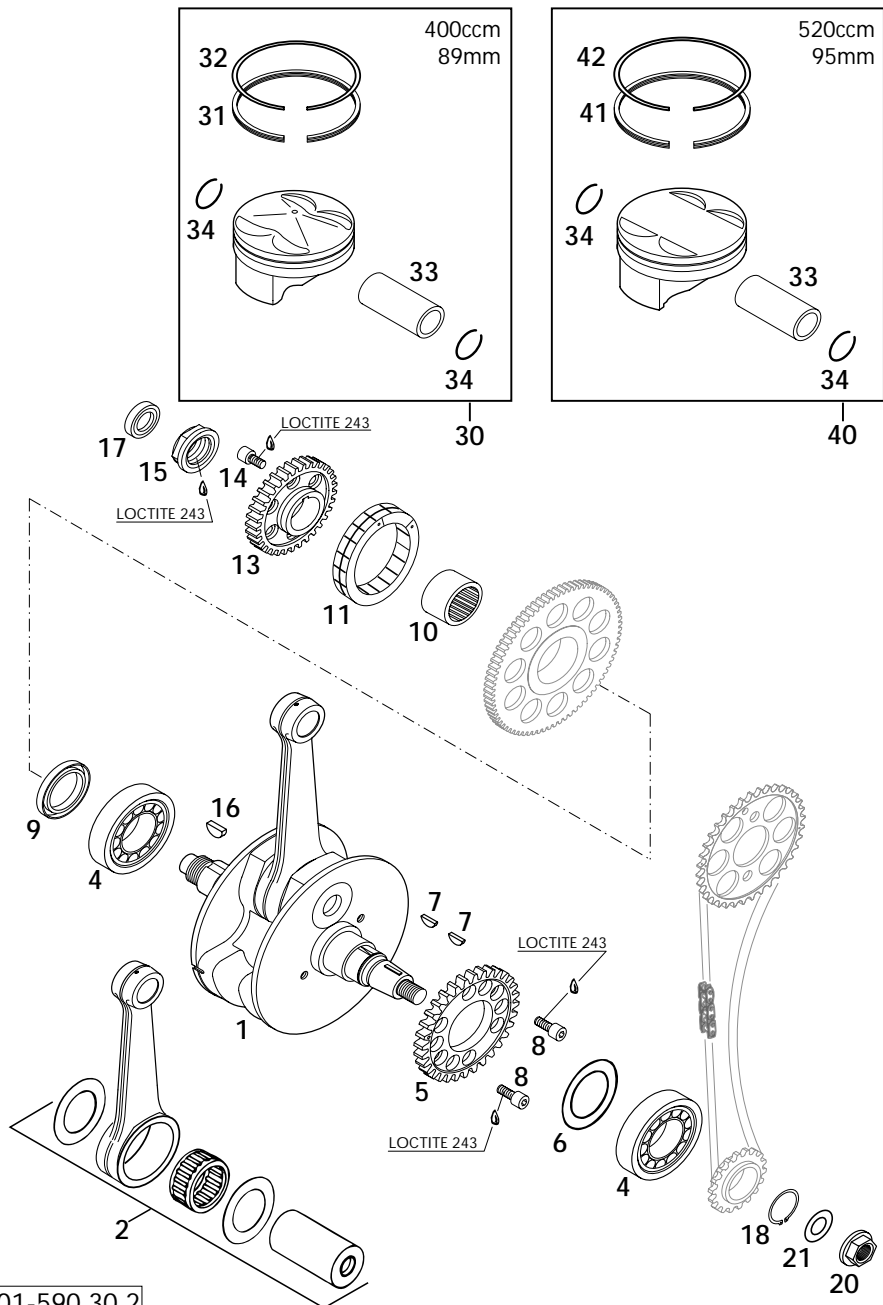

FIG	TEILNR/PARTNR	BEZEICHNUNG	DESCRIPTION	QTY
1*	595.30.018.200	KURBELWELLE KPL. 400 RAC. 2001 HUB 64MM, OHNE ANLAUFSCHLEIBEN	CRANKSHAFT CPL. 400 RAC. 2001 STROKE 64MM, WITHOUT WASHER	1
1*	590.30.018.200	KURBELWELLE KPL. 520 RAC. 2001 HUB 72MM, OHNE ANLAUFSCHLEIBEN	CRANKSHAFT CPL. 520 RAC. 2001 STROKE 72MM, WITHOUT WASHER	1
2	595.30.015.044	PLEUEL.REP.SATZ 400 RAC. 2000 MIT ANLAUFSCHLEIBEN	CON.ROD REP.SET 400 RAC. 2000 WITH WASHER	1
2	590.30.015.044	PLEUEL.REP.SATZ 520 RAC. 2000 MIT ANLAUFSCHLEIBEN	CON.ROD REP. SET 520 RAC. 2000 WITH WASHER	1
4	503.30.082.000	ZYLINDERR.LAGER NJ206 ET2XCS46	CYL.ROLLER BEAR.NJ206 ET2XCS46	2
5	590.30.055.000	ANTRIEBSRAD 32-Z FÜR AGW	DRIVE GEAR 32-T F.BALANC.SHAFT	1
6	560.30.081.000	PASSSCHEIBE 30,5X45X0,10	THRUST WASHER 30X42X0,1	X
6	560.30.081.100	PASSSCHEIBE 30,5X45X0,15	THRUST WASHER 30X42X0,15	X
6	560.30.081.200	PASSSCHEIBE 30,5X45X0,30	THRUST WASHER 30X42X0,3	X
7	0888 030050	SCHEIBENFEDER DIN6888-3X5X13	WOODRUFF KEY DIN6888-3X5X13	2
8	0984 060162	ZYL.SCHRAUBE DIN7984-M 6X16	AH SCREW DIN7984-M 6X16	2
9	0760 304771	WELLENDICHTRING 30X47X7 VITON	SHAFT SEAL RING 30X47X7 VITON	1
10	0618 301617	NADELHÜLSE HK 3016 B	NEEDLE BEARING HK 3016 B	1
11	584.40.026.000	FREILAUF FWD 332008 BLS	FREE-WHEEL FWD 332008 BLS	1
13	590.32.000.033	PRIMÄRRAD 33-Z	PRIMARY GEAR 33-T	1
14	0912 060106	ISK.SCHR. DIN0912-M 6X10 10.9	AH SCREW DIN0912-M 6X10 10.9	6
15	590.30.029.100	SK-MUTTER M20X1,5 SW=27 LINKS	HH NUR M20X1,5 WS=27 LEFT	1
16	6946 005	SCHEIBENFEDER 5X6,5 GEHÄRTET	WOODRUFF KEY 5X6,5 HARDED	1
17	0760 142460	WELLENDICHTRING 14X24X6 B	SHAFT SEAL RING 14X24X6 B	1
18	0471 250120	SICHERUNGSRING DIN0471-25X1,2	CIRCLIP DIN0471-25X1,2	1
20	490.30.021.000	BUNDMUTTER M12X1 RECHTS	COLLAR NUT M12X1 R/S	1
21	0137 120000	FEDERSCHLEIBE DIN0137-B12	SPRING WASHER DIN0137-B12	1
30	595.30.007.000/ I	KOLBEN I 89MM KPL. GEGOSS.2000	PISTON I 89MM CPL. CAST 2000	1
30	595.30.007.000/ II	KOLBEN II 89MM KPL.GEGOSS.2000	PISTON II 89MM CPL. CAST 2000	1
31	595.30.031.000	ÖLABSTREIFRING 89/81,5X3	OIL SCRAPER RING 89/81,5X3	1
32	575.30.032.000	RECHTECKRING 89MM	RECTANGULAR RING 89MM	1
33	590.30.033.000	KOLBENBOLZEN 20X15,8/12X50	PISTON PIN BOLT 20X15,8/12X50	1
34	590.30.074.000	DRAHTSPRENGRING C20X1,5	CIRCLIP C20X1,5	2
40	590.30.007.000/ I	KOLBEN I 95MM KPL. GESCHM.2000	PISTON I 95MM CPL. FORGED 2000	1
40	590.30.007.000/ II	KOLBEN II 95MM KPL.GESCHM.2000	PISTON II 95MM CPL.FORGED 2000	1
41	580.30.631.000	ÖLABSTREIFRING 95MM	OIL SCRAPER RING 95MM	1
42	590.30.032.000	RECHTECKRING 95/87,2X1,25	RECTANGULAR RING 95/87,2X1,25	1

* = NEUTEIL / NEW PART X = NACH BEDARF / AS REQUIRED

FIG	TEILNR/PARTNR	BEZEICHNUNG	DESCRIPTION	QTY
1*	590.30.057.044	AUSGLEICHSWELLE KPL. RAC. 2001	BALANCER SHAFT CPL. RAC. 2001	1
2	0625 160040	RILLENKUGELLAGER TM 16004 C3	GROOVED BALL BEARING 16004 C3	2
6	0760 142460	WELLENDICHTRING 14X24X6 B	SHAFT SEAL RING 14X24X6 B	1

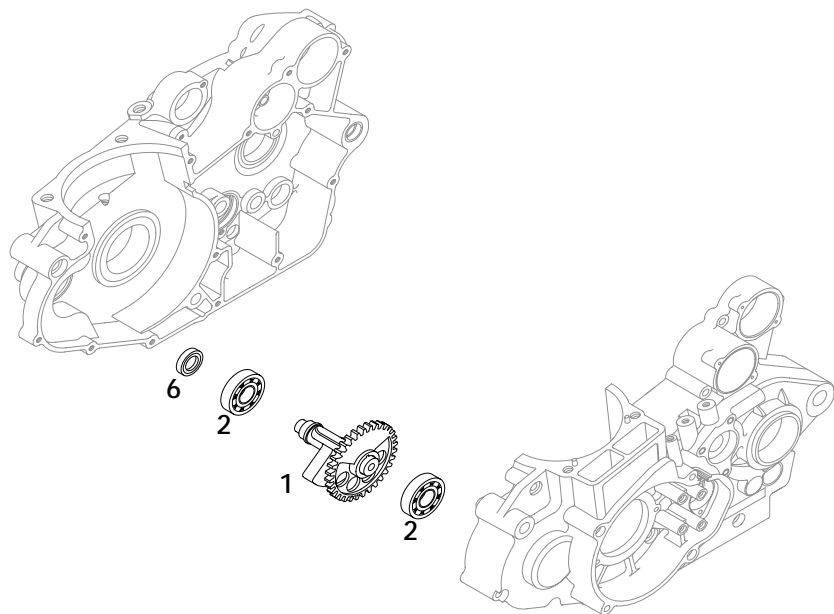
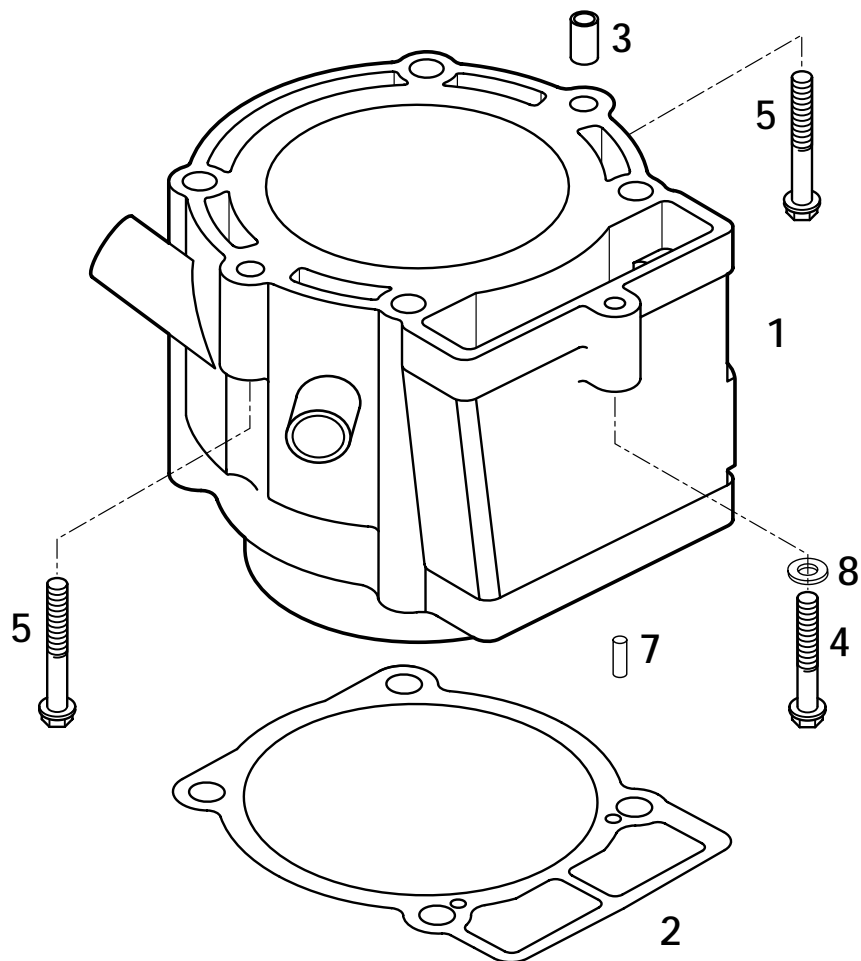
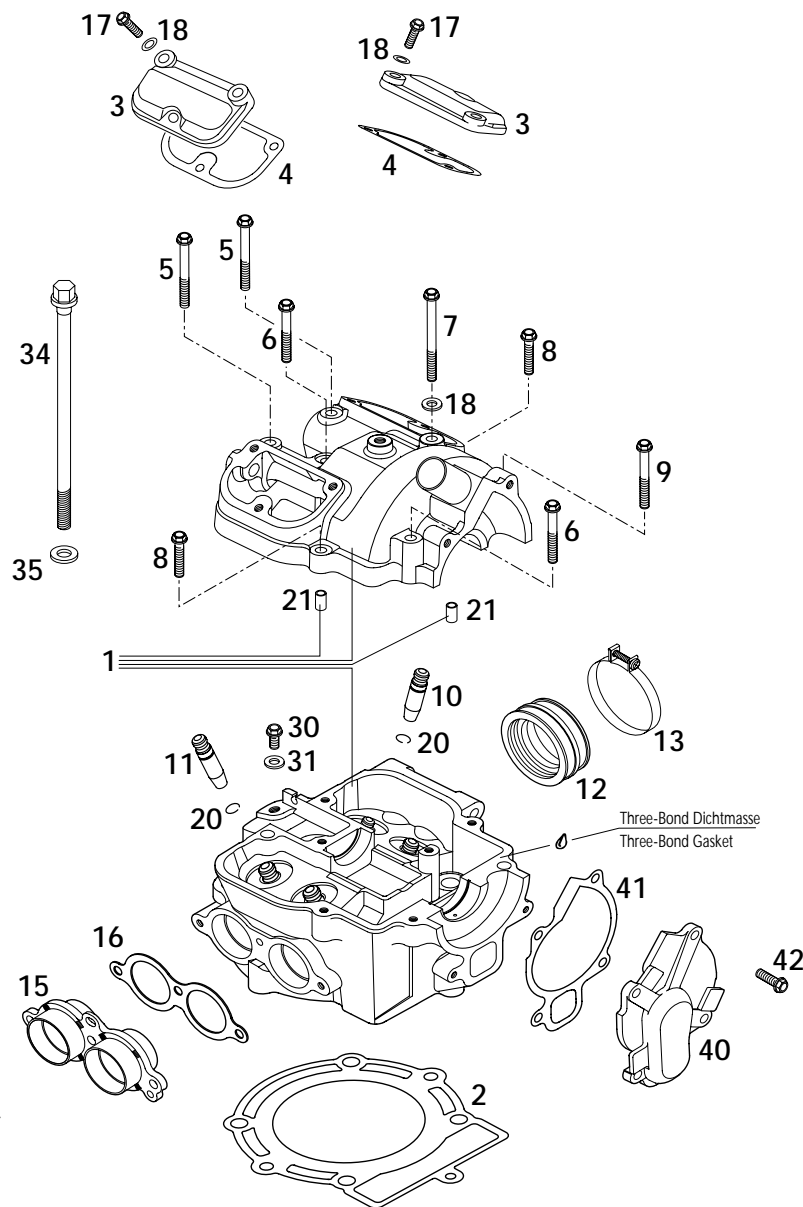

FIG	TEILNR/PARTNR	BEZEICHNUNG	DESCRIPTION	QTY
1	595.30.005.000	ZYLINDER 89MM 400 RACING 2000	CYLINDER 89MM 400 RACING 2000	1
1	590.30.005.000	ZYLINDER 95MM 520 RACING 2000	CYLINDER 95MM 520 RACING 2000	1
2	590.30.035.050	ZYLINDERFUSSDICHTUNG 0,5MM	CYLINDER BASE GASKET 0,5MM	1
3	590.30.023.000	PASSHÜLSE 6X8X11,5	DOWEL 6X8X11,5	2
4	0015 060403	SK.BUNDSCHRAUBE M 6X40 SW=8	HH COLLAR SCREW M 6X40 WS=8	1
5	0015 060453	SK.BUNDSCHRAUBE M 6X45 SW=8	HH COLLAR SCREW M 6X45 WS=8	2
7	0402 040980	NADELROLLE DIN5402 NRB 4X 9,8	NEEDLE ROL.DIN5402 NRB 4X 9,8	2
8*	0603 061001	CU-DICHTRING DIN7603- 6X10X1	CU-SEAL RING DIN7603- 6X10X1	1





LOCTITE 243

FIG	TEILNR/PARTNR	BEZEICHNUNG	DESCRIPTION	QTY
1*	590.36.020.044	ZYLINDERKOPF KPL. 400/520 2000	CYLINDERHEAD CPL. 400/520 2000	1
2	595.30.036.000	ZYLINDERKOPFDICHTUNG 89,3 MM 400 RACING	CYLINDER HEAD GASKET 89,3 MM 400 RACING	1
2	590.30.036.000	ZYLINDERKOPFDICHTUNG 95,3 MM 520 RACING	CYLINDER HEAD GASKET 95,3 MM 520 RACING	1
3	580.36.052.000	VENTILDECKEL HINTEN	VALVE COVER REAR	2
4	580.36.053.000	VENTILDECKELDICHTUNG	VALVE COVER GASKET	2
5	0015 060553	SK.BUNDSCHRAUBE M 6X55 SW=8	HH COLLAR SCREW M 6X55 WS=8	2
6	0015 060453	SK.BUNDSCHRAUBE M 6X45 SW=8	HH COLLAR SCREW M 6X45 WS=8	2
7	0015 060753	SK.BUNDSCHRAUBE M 6X75 SW=8	HH COLLAR SCREW M 6X75 WS=8	1
8	0015 060303	SK.BUNDSCHRAUBE M 6X30 SW=8	HH COLLAR SCREW M 6X30 WS=8	2
9	0015 060503	SK.BUNDSCHRAUBE M 6X50 SW=8	HH COLLAR SCREW M 6X50 WS=8	1
10	590.36.025.000	VENTILFÜHRUNG EINLASS	VALVE GUIDE INTAKE 36,5MM	2
11	590.36.026.000	VENTILFÜHRUNG AUSLASS	VALVE GUIDE EXHAUST 40,5MM	2
12	590.36.044.000	GUMMIMUFFE RACING NBR82	INTAKE BOOT RACING NBR82	1
13	590.30.061.000	SCHELLE D=56MM B=9MM M4X25	CLAMP D=56MM B=9MM M4X25	2
15	590.36.039.000	AUSPUFFFLANSCH KPL. RACING	EXHAUST FLANGE CPL. RACING	1
16	590.36.041.000	DICHTUNG AUSPUFFFLANSCH	GASKET EXHAUST FLANGE 1MM	1
17	0015 060203	SK.BUNDSCHRAUBE M 6X20 SW=8	HH COLLAR SCREW M 6X20 WS=8	6
18	0603 061001	CU-DICHTRING DIN7603- 6X10X1	CU-SEAL RING DIN7603- 6X10X1	7
19	0015 060163	SK.BUNDSCHRAUBE M 6X16 SW=8	HH COLLAR SCREW M 6X16 WS=8	3
20	0993 012000	SPRENGRING DIN7993-RW12	CIRCLIP DIN7993A-RW12	4
21	590.30.023.000	PASSHÜLSE 6X8X11,5	DOWEL 6X8X11,5	2
30	590.36.006.090	ENTLÜFTUNGSSCHRAUBE M6X10 KPL.	VENT SCREW M6X10 CPL.	1
31*	580.36.065.100	CU-DICHTRING 6 X 10 X 2	CU-SEAL RING 6 X 10 X 2	1
34	590.36.079.000	ZYLINDERKOPFSCHRAUBE M10X158	CYLINDER HEAD SCREW M10X158	4
35	590.36.090.000	SCHEIBE 10,8X18,8X1,5	SHIM 10,4X18,8X1,5	4
40	590.35.052.000	WASSERPUMPENDECKEL RACING 2000	WATER PUMP COVER RACING 2000	1
41	590.35.053.000	WASSERPUMPENDECKELDICHTUNG 0,8MM	WATER PUMP COVER GASKET 0,5MM	1
42	0015 060203	SK.BUNDSCHRAUBE M 6X20 SW=8	HH COLLAR SCREW M 6X20 WS=8	4

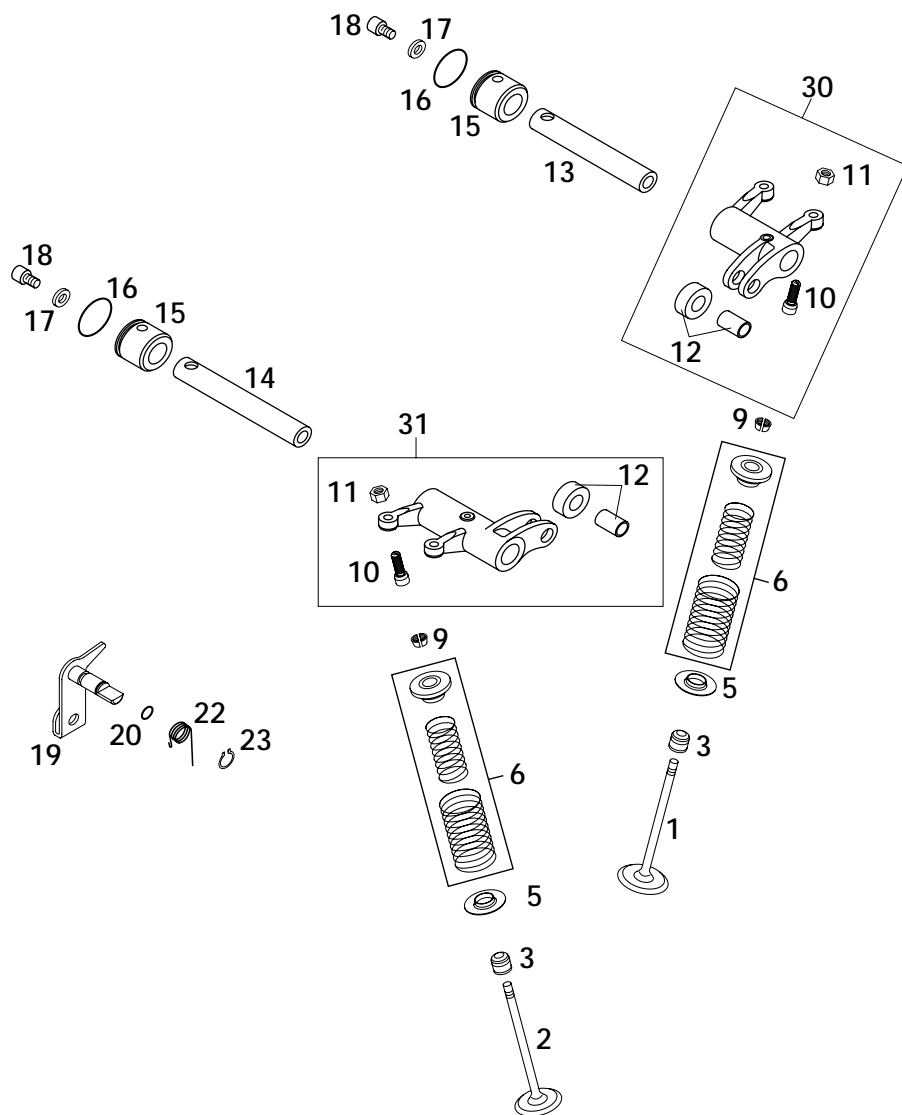

FIG	TEILNR/PARTNR	BEZEICHNUNG	DESCRIPTION	QTY
1	590.36.030.000	EINLASSVENTIL D=35MM	INTAKE VALVE D=35MM	2
2	590.36.031.000	AUSLASSVENTIL D=30MM	EXHAUST VALVE D=30MM	2
3	590.36.027.000	VENTILSCHAFTDICHTUNG RACING	VALVE-STEM SEALING RACING	4
5	590.36.036.000	VENTILFEDERAUFLAGE	VALVE SPRING HOLDER	4
6*	590.36.028.144	VENTILFEDERNKIT (1X) RAC. 2001	VALVE SPRING KIT (1X) RAC.2001	4
9	590.36.033.000	VENTILKEGELSTÜCK KK 6 H	VALVE COLLET	8
10	590.36.062.000	EINSTELLSCHRAUBE M6X0,75	ADJUSTMENT SCREW M6X0,75	4
11	590.36.062.100	MUTTER M6X0,75	NUT M6X0,75	4
12	590.36.061.090	KIPPEBELROLLE KPL. RACING	ROCKER ARM ROLLER CPL. RACING	2
13	590.36.056.000	KIPPEBELACHSE EINLASS	ROCKER ARM SHAFT INTAKE 82MM	1
14	590.36.057.000	KIPPEBELACHSE AUSLASS	ROCKER ARM SHAFT EXHAUST 94MM	1
15	590.36.061.095	ENDKAPPE KIPPEBELACHSE	END CAP ROCKER ARM SHAFT	2
16	0770 191016	O-RING 19,10X1,60 NBR 70	O-RING 19,10X1,60 NBR 70	2
17	590.36.060.010	SCHEIBE ALU 5,2X10X2	SHIM ALU 5,2X10X2	2
18	0912 050083	ISK.SCHRAUBE DIN0912-M 5X 8	AH SCREW DIN0912-M 5X 8	2
19	590.36.050.000	DEKOWELLE KPL.	DECOMPRESSION SHAFT CPL.	1
20	0770 051016	O-RING 5,10X1,60 NBR 70	O-RING 5,10X1,60 NBR 70	1
22	590.36.059.000	DEKOHEBELFEDER	DECOMPRESSION LEVER SPRING	1
23	0471 080000	SICHERUNGSRING DIN0471- 8X0,8	CIRCLIP DIN0471- 8X0,8	1
30	590.36.060.044	KIPPEBEL EINLASS KPL. L=50MM	ROCKER ARM INTAKE CPL. L=50MM	1
31	590.36.061.044	KIPPEBEL AUSLASS KPL.L=66,7MM	ROCKERARM EXHAUST CPL.L=66,7MM	1

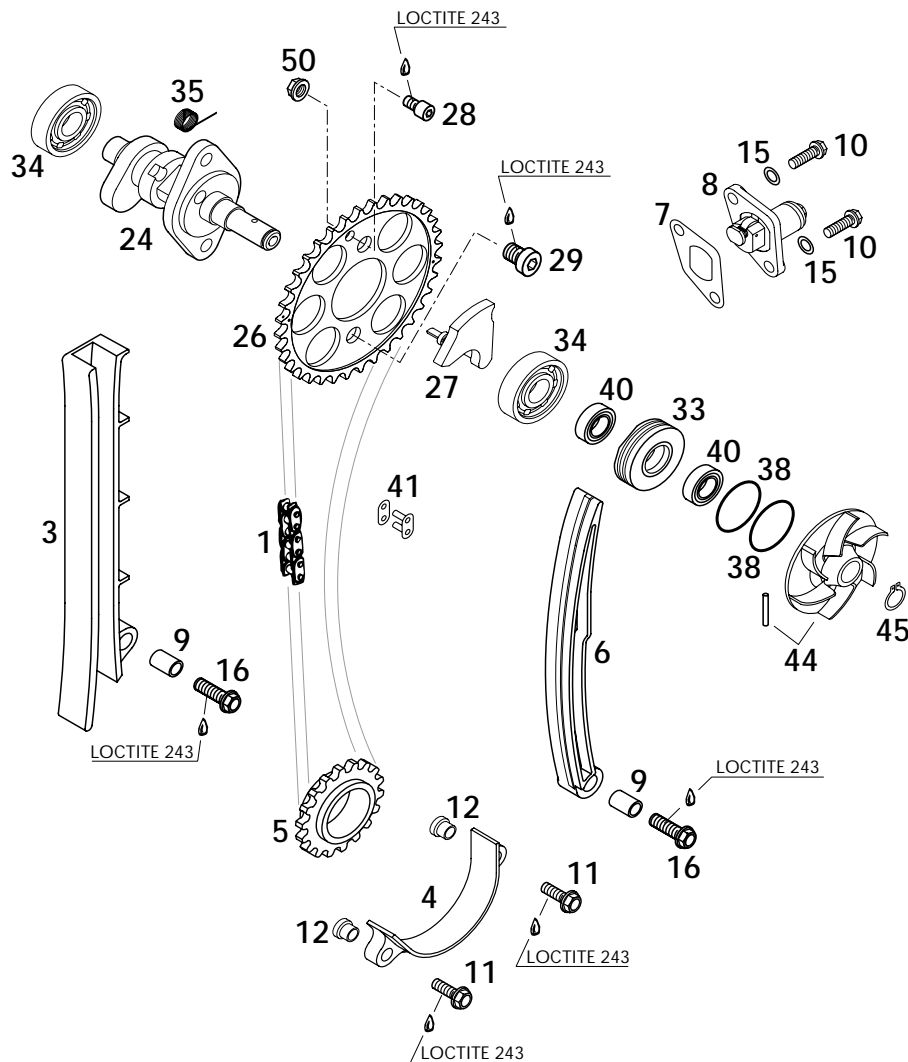

FIG	TEILNR/PARTNR	BEZEICHNUNG	DESCRIPTION	QTY
1	590.36.013.000	STEUERKETTE 97 ROLLEN	TIMING CHAIN 97 ROLLS	1
3	590.36.001.000	STEUERKETTENFÜHRUNG RACING	TIMING CHAIN GUIDE RACING	1
4	590.36.018.000	AUSFALLSICHERUNG RACING	SECURING GUIDE RACING	1
5	590.36.014.000	STEUERRITZEL 18-Z	TIMING GEAR 18-T	1
6	590.36.002.000	STEUERKETTENSPIANNERSCHIENE	TIMING CHAIN TENSIONER	1
7	590.36.003.050	DICHTUNG STEUERKETTENSPIANNER	GASKET TIMING CHAIN TENSIONER	1
8	590.36.003.000	STEUERKETTENSPIANNER KPL.RACING	TIMINGCHAIN TENSIONER CPL.RAC.	1
9	590.36.001.050	DISTANZBÜCHSE 6,1X8,2X13,1	SPACER BUSHING 6,1X8,2X13,1	2
10	0015 060203	SK.BUNDSCHRAUBE M 6X20 SW=8	HH COLLAR SCREW M 6X20 WS=8	2
11	0015 050163	SK.BUNDSCHRAUBE M 5X16 SW=8	HH COLLAR SCREW M 5X16 WS=8	2
12	590.36.018.050	STÜTZHÜLSE 5,2X7X10X7,7	SUPPORTING SLEEVE 5,2X7X10X7,7	2
15	0603 061001	CU-DICHRING DIN7603- 6X10X1	CU-SEAL RING DIN7603- 6X10X1	2
16	0015 060253	SK.BUNDSCHRAUBE M 6X25 SW=8	HH COLLAR SCREW M 6X25 WS=8	2
24	590.36.010.000	NOCKENWELLE „55“ 520 RAC. 2000	CAMSHAFT „55“ 520 RACING 2000	1
24	595.36.010.000	NOCKENWELLE „01“ 400 RAC. 2000	CAMSHAFT „01“ 400 RACING 2000	1
26	590.36.011.000	NOCKENWELLENRAD 36-Z	CAMSHAFT GEAR 36-T	1
27	590.36.016.000	AUTODEKOWELLE	AUTO DECOMPRESSION SHAFT	1
28	0912 050106	ISK.SCHRAUBE M5X10 DIN912 10.9	AH SCREW M5X10 DIN912 10.9	1
29	0984 080103	ISK.SCHRAUBE DIN7984-M 8X10	AH SCREW DIN7984-M 8X10 8.8	2
33	590.36.081.000	DICHTUNGSTRÄGER 33X11	GASKET SUPPORT 33X11	1
34	0625 062014	RILLENKUGELLAGER 6201 C3 NTN	BALL BEARING 6201 C3 NTN	2
35	590.36.017.000	FEDER FÜR AUTODEKO	SPRING 0,55MM FOR AUTODECOMPR.	1
38*	0770 020220	O-RING 25,12X1,78 NBR70	O-RING 25,12X1,78 NBR70	2
40*	0760 101842	WELLENDICHTR. 10X18X4 B-NBR SB	SHAFT SEAL R.10X18X4 B-NBR SB	2
41	590.36.013.050	NIETGLIED FÜR STEUERKETTE	RIVET LINK FOR TIMING CHAIN	1
44*	590.35.055.144	WASSERPUMPENRAD KPL. RAC. 2001	WATER PUMP WHEEL CPL. RAC.2001	1
45	0471 100010	SICHERUNGSRING DIN0471-10X1	CIRCLIP DIN0471-10X1	1
50	0985 050003	SS.MUTTER DIN0985-M 5	SELF LOCKING NUT DIN0985-M 5	1

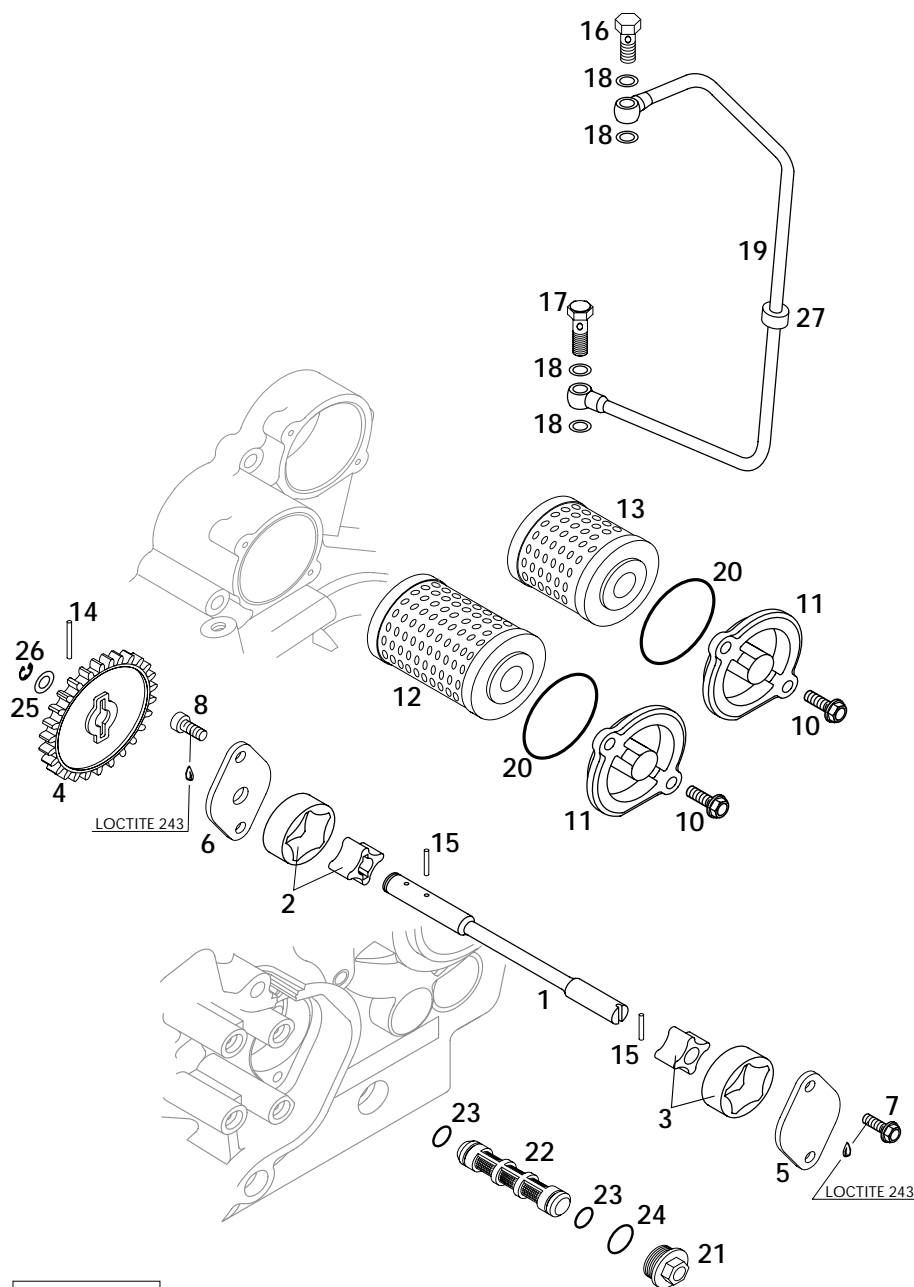

FIG	TEILNR/PARTNR	BEZEICHNUNG	DESCRIPTION	QTY
1	590.38.002.000	ÖLPUMPENWELLE	OIL PUMP SHAFT L=148,5MM	1
2	590.38.011.010	ÖLPUMPENROTOR KPL. 10MM G-73R	OILPUMP ROTOR CPL. 10MM G-73R	1
3	590.38.011.012	ÖLPUMPENROTOR KPL. 12MM G-95	OILPUMP ROTOR CPL. 12MM G-95	1
4	584.38.001.000	ÖLPUMPENRAD 26-Z	OIL PUMP GEAR 26-T	1
5	590.38.004.000	ÖLPUMPENDECKEL LINKS	OIL PUMP COVER L/S	1
6	590.38.003.000	ÖLPUMPENDECKEL RECHTS 8MM	OIL PUMP COVER R/S 8MM	1
7	0015 050163	SK.BUNDSCHRAUBE M 5X16 SW=8	HH COLLAR SCREW M 5X16 WS=8	2
8	0984 050122	ZYL.SCHRAUBE DIN6912-M 5X12	AH SCREW DIN6912-M 5X12	2
10	0015 050163	SK.BUNDSCHRAUBE M 5X16 SW=8	HH COLLAR SCREW M 5X16 WS=8	4
11	590.38.041.000	ÖLFILTERDECKEL RACING	OIL FILTER COVER RACING	2
12	580.38.005.000	ÖLFILTER LANG	OIL FILTER LONG	1
13	590.38.046.000	ÖLFILTER KURZ	OIL FILTER SHORT	1
14	0402 251980	NADELROL. DIN5402 NRA 2,5X19,8	NEEDLEROL. DIN5402 NRA 2,5X19,8	1
15	0402 251180	NADELROLLE DIN5402 NRB2,5X11,8	NEEDLE ROLLER DIN5402 2,5X11,8	2
16	580.38.030.000	HOHLSCHRAUBE M 8 X 1 DIN7643	BANJO BOLT M8 X 1 DIN7643	1
17	590.38.029.000	DÜSENSCHRAUBE „100“ M8X1 SW=12	JET SCREW „100“ M8X1 WS=12	1
18	0603 082121	CU-DICHTRING DIN7603- 8X12X1	SEAL RING CU DIN7603- 8X12X1	4
19	590.38.035.000	ÖLLEITUNG STAHL GEHÄUSE-Z.KOPF	OIL LINE STEEL CASE-CYL.HEAD	1
20	0770 400025	O-RING 40,00X2,50 NBR 70	O-RING 40,00X2,50 NBR 70	2
21	590.38.017.000	VERSCHL.SCHRAUBE M20X1,5 SW=13	PLUG M20X1,5 WS=13	1
22	590.38.016.000	ÖLSIEB	OIL SCREEN 15X83MM	1
23	0770 125015	O-RING 12,5X1,5 NBR	O-RING 12,5X1,5 NBR	2
24	0770 020170	O-RING 17,17X1,78 GLO	O-RING 17,17X1,78 GLO	1
25	580.38.007.755	ANLAUFSCHIEBE 8,1 X 15 X 0,5	STOP DISK 8,1 X 15 X 0,5	1
26	0799 060000	SICH.SCHIEBE DIN6799-RS 6,0	TAB WASHER DIN6799-RS 6,0	1
27*	584.05.098.000	GUMMIPUFFER 8X17X10 ENDDÄM.'97	RUBBERBUFFER 8X17X10 SILENC'97	1

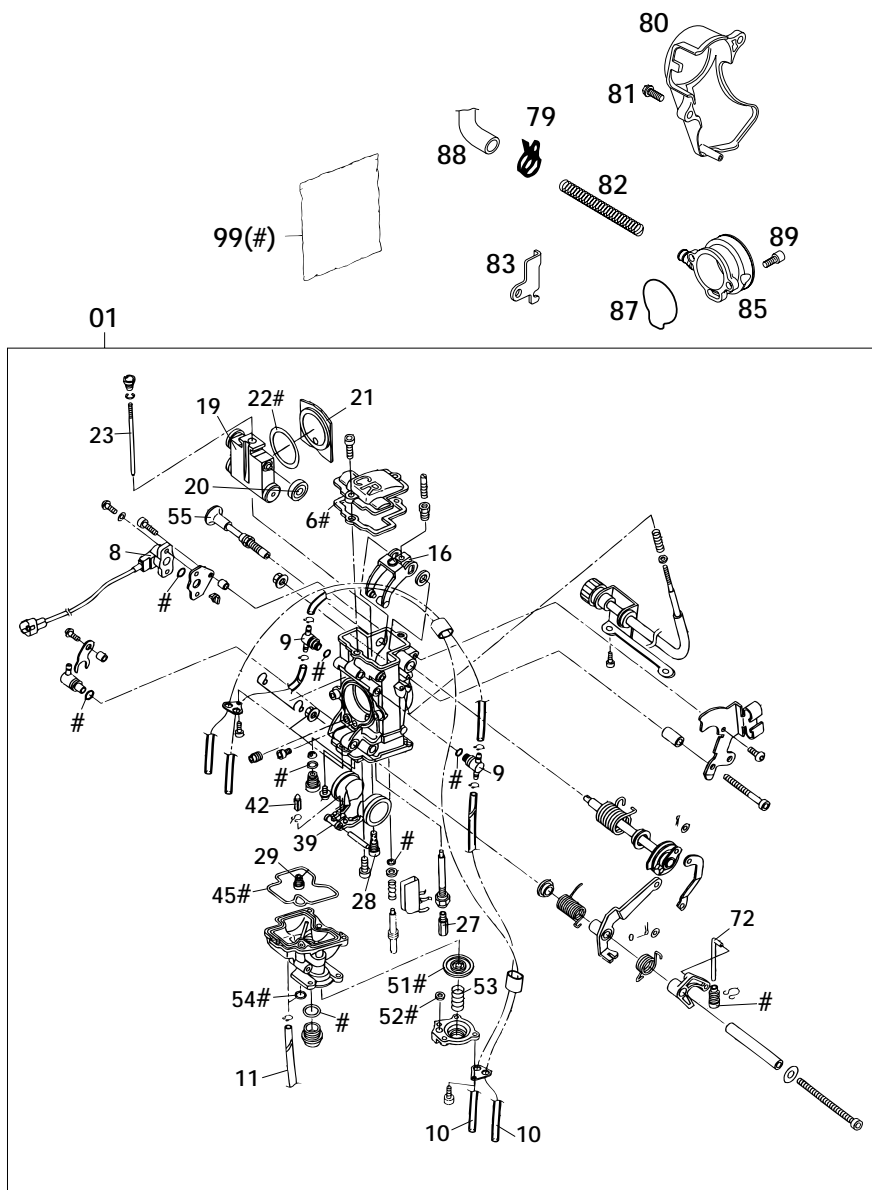

FIG	TEILNR/PARTNR	BEZEICHNUNG	DESCRIPTION	QTY
01	590.31.001.000	VERGASER KEIHIN MX FCR 39 2000	CARBURETOR KEIH. MX FCR39 2000	1
6	590.31.028.000	DICHTUNG VERGASERDECKEL	GASKET CARBURETOR COVER	1
8	590.31.077.000	SENSOR GASSCHIEBERPOSITION	THROTTLE POSITION SENSOR	1
9	590.31.083.000	T-STÜCK ENTLÜFTUNGSSCHLAUCH	T-JOINT BREATHER HOSE	2
10	310.07.007.101	PVC-SCHLAUCH 4 X 6 MM	BREATHER HOSE 4 X 6 MM	2,2
11	520.31.137.001	PVC-SCHLAUCH 3 X 6 MM	PVC-HOSE 3 X 6 MM	0,3
16	590.31.035.051	GASSCHIEBERARM KPL.	LINK ARM THROTTLE VALVE CPL.	1
19	590.31.035.015	GASSCHIEBER 15 KPL.	THROTTLE VALVE 15 CPL.	1
20	590.31.035.050	LAGERROLLE GASSCHIEBER	BEARING THROTTLE VALVE	1
21	590.31.035.053	DICHTPLATTE GASSCHIEBER	GASKET PLATE THROTTLE VALVE	1
22	590.31.035.052	DICHTSCHEIBE GASSCHIEBER	GASKET WASHER THROTTLE VALVE	1
23	590.31.034.0VR	DÜSENNADEL OB DVR	JET NEEDLE OB DVR	1
23	590.31.034.0TM	DÜSENNADEL OB DTM	JET NEEDLE OB DTM	1
27*	545.31.623.172	HAUPTDÜSE GR.172 KEIHIN	MAIN JET 172 KEIHIN	X
27*	545.31.623.175	HAUPTDÜSE GR.175 KEIHIN	MAIN JET 175 KEIHIN	1
27*	545.31.623.178	HAUPTDÜSE GR.178 KEIHIN	MAIN JET 178 KEIHIN	X
27*	545.31.623.180	HAUPTDÜSE GR.180 KEIHIN	MAIN JET 180 KEIHIN	X
28	590.31.607.048	LEERLAUFDÜSE 48	IDLE JET 48	1
28	590.31.607.050	LEERLAUFDÜSE 50	IDLE JET 50	X
28	590.31.607.052	LEERLAUFDÜSE 52	IDLE JET 52	1
29	590.31.051.085	STARTDÜSE 85	STARTER JET 85	1
39	590.31.009.000	SCHWIMMER KPL.	FLOAT CPL.	1
42*	546.31.220.000	SCHWIMMERNADEL	FLOAT NEEDLE	1
45	590.31.010.000	DICHTUNG SCHWIMMERGEHÄUSE	GASKET FLOAT CHAMBER	1
51	590.31.057.000	MEMBRAN BESCHLEUNIGERPUMPE	DIAPHRAGM ACCELERATOR PUMP	1
52	590.31.058.000	U-RING	U-RING	1
53	590.31.059.000	DRUCKFEDER	COIL SPRING	1
54	590.31.058.100	O-RING	O-RING	1
55	590.31.048.000	KALTSTARTBETÄTIGUNG KPL.	STARTER VALVE CPL.	1
72	590.31.061.000	GESTÄNGE BESCHLEUNIGERPUMPE	ROD ACCELERATOR PUMP	1
79*	584.31.082.100	YDNAC-KLAMMER 16MM '98	YDNAC-CLAMP 16MM '98	1
80	590.31.086.000	VERGASERABDECKUNG RACING 2000	CARBURETOR COVER RACING 2000	1
81	0015 060163	SK.BUNDSCHRAUBE M 6X16 SW=8	HH COLLAR SCREW M 6X16 WS=8	2
82	320.03.073.000	DRUCKFEDER	PRESSURE SPRING	1
83	590.31.029.024	SCHIEBERANSCHLAG 24,5MM	SLIDE STOP 24,5MM	1
85*	590.31.040.100	ANSAUGTRICHTER 2001	INTAKE FUNNEL 2001	1
87	590.31.040.010	O-RING FÜR ANSAUGTRICHTER	O-RING FOR INTAKE FUNNEL	1
88	590.31.050.000	SCHLAUCH MOTORENTLÜFTUNG 0,71M	TUBE ENGINE BREATHER 0,71M	1
89	0912 050123	ISK.SCHRAUBE DIN0912-M 5X12	AH SCREW DIN0912-M 5X12	2
99	590.31.099.000	DICHTUNGSSATZ FCR39 KEIHIN	GASKET SET FCR39 KEIHIN	1

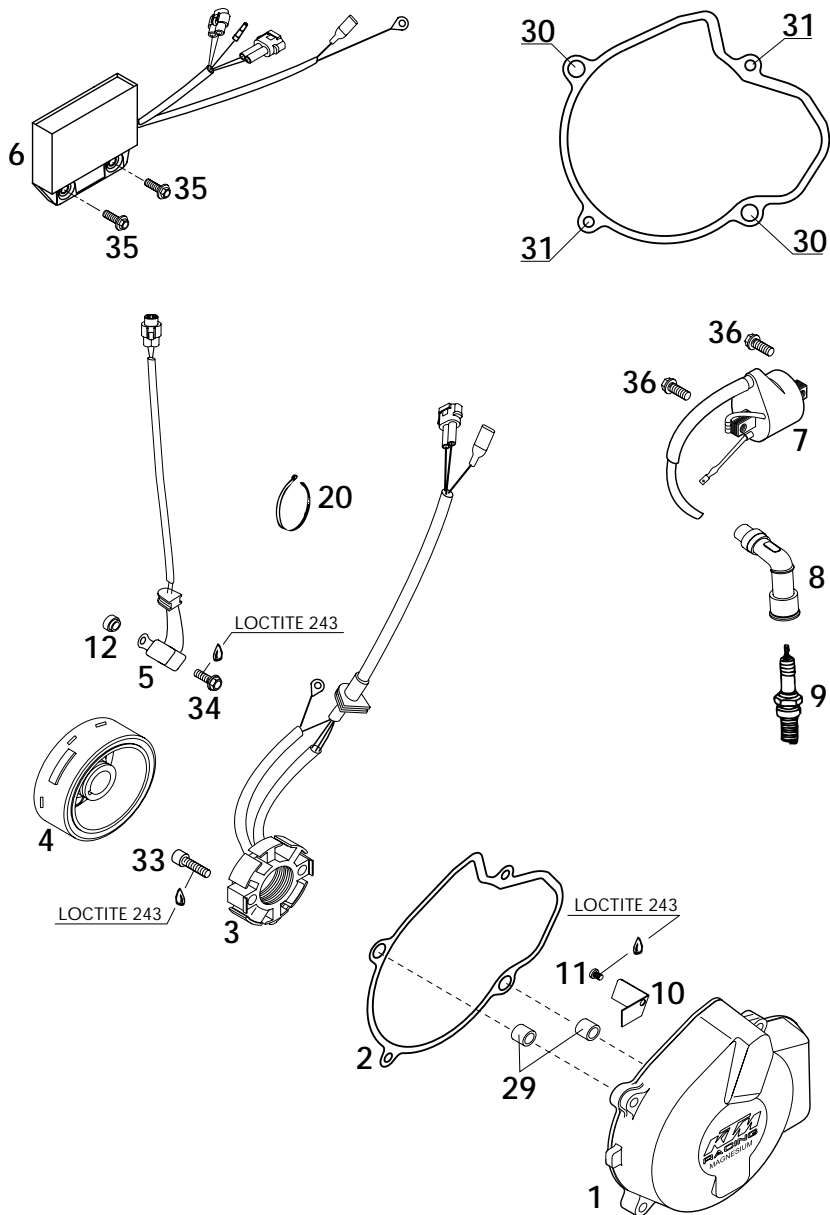

FIG	TEILNR/PARTNR	BEZEICHNUNG	DESCRIPTION	QTY
1	590.30.002.500	ZÜNDUNGSDECKEL 4K3A 2000	IGNITION COVER 4K3A 2000	1
2	590.30.040.000	ZÜNDUNGSDECKELDICHUNG 0,5MM	IGNITION COVER GASKET 0,5MM	1
3	590.39.004.000	STATOR KPL. 4K3A RACING 2000	STATOR CPL. 4K3A RACING 2000	1
4	590.39.005.000	ROTOR 4K3A RACING 2000	FLYWHEEL 4K3A „K9158“ RAC.2000	1
5	590.39.034.000	IMPULSGEBER KOKUSAN 4K3-A/B	PULSER COIL KOKUSAN 4K3-A/B	1
6	590.39.031.100	DIGITALBOX KOKUSAN 4K3-A/B	DIGITALBOX KOKUSAN 4K3-A/B	1
7	590.39.006.000	ZÜNDSPULE KOKUSAN 4K3-A/B 2000	IGNITIONCOIL KOKUSAN 4K3-A/B	1
8	590.39.090.000	ZÜNDKERZENSTECKER VD05FG 2000	SPARK PLUG CONNECT.VD05FG 2000	1
9	590.39.093.000	ZÜNDKERZE CR8EK	SPARK PLUG CR8EK	1
10	590.30.002.050	HALTEBLECH FÜR KABEL	SUPPORT FOR WIRE	1
11	0084 040063	ZYL.SCHRAUBE DIN0084-M 4X 6 A	CYL.HEAD SCREW DIN0084-M 4X 6A	1
12	590.39.009.000	DISTANZBÜCHSE 5,2X7X4,8 2000	SPACER BUSHING 5,2X7X4,8 2000	2
20	440.11.076.100	KABELBAND 100MM	CABLE TIE 100MM	X
29	490.30.090.000	PASSHÜLSE 9,8 X 7 X 10	DOWEL 9,8 X 7 X 10	2
30	0015 060353	SK.BUNDSCHRAUBE M 6X35 WS=8	HH COLLAR SCREW M 6X35 WS=8	2
31	0015 060303	SK.BUNDSCHRAUBE M 6X30 WS=8	HH COLLAR SCREW M 6X30 WS=8	2
33	0912 050253	ISK.SCHRAUBE DIN0912-M 5X25	AH SCREW DIN0912-M 5X25	2
34	0015 050163	SK.BUNDSCHRAUBE M 5X16 WS=8	HH COLLAR SCREW M 5X16 WS=8	2
35	0014 060203	SK.BUNDSCHRAUBE M 6X20 WS=8	HH COLLAR SCREW M 6X20 WS=8	2
36	0015 060163	SK.BUNDSCHRAUBE M 6X16 WS=8	HH COLLAR SCREW M 6X16 WS=8	2

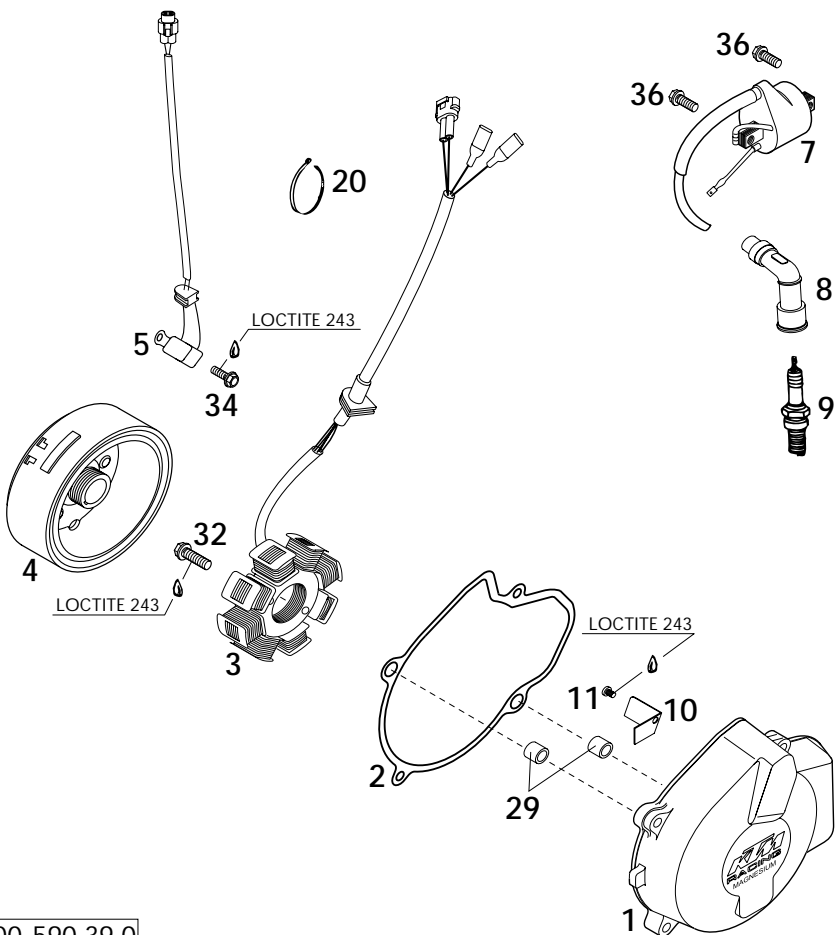
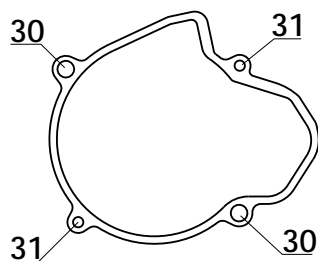
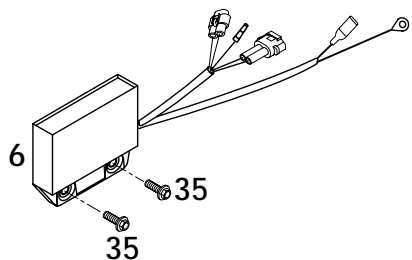

FIG	TEILNR/PARTNR	BEZEICHNUNG	DESCRIPTION	QTY
1	590.30.002.000	ZÜNDUNGSDECKEL 4K3B PULVERBESCHICHTET	IGNITION COVER 4K3B PULVERIZED	1
2	590.30.040.000	ZÜNDUNGSDECKELDICHUNG 0,5MM	IGNITION COVER GASKET 0,5MM	1
3	590.39.104.000	STATOR KPL. 4K3B RACING 2000	STATOR CPL. 4K3B RACING 2000	1
4*	590.39.105.100	ROTOR 4K3B RACING 2001	FLYWHEEL 4K3B RAC. 2001	1
5	590.39.034.000	IMPULSGEBER KOKUSAN 4K3-A/B	PULSER COIL KOKUSAN 4K3-A/B	1
6	590.39.031.100	DIGITALBOX KOKUSAN 4K3-A/B	DIGITALBOX KOKUSAN 4K3-A/B	1
7	590.39.006.000	ZÜNDSPULE KOKUSAN 4K3-A/B 2000	IGNITIONCOIL KOKUSAN 4K3-A/B	1
8	590.39.090.000	ZÜNDKERZENSTECKER VD05FG 2000	SPARK PLUG CONNECT.VD05FG 2000	1
9	590.39.093.000	ZÜNDKERZE CR8EK	SPARK PLUG CR8EK	1
10	590.30.002.050	HALTEBLECH FÜR KABEL	SUPPORT FOR WIRE	1
11	0084 040063	ZYL.SCHRAUBE DIN0084-M 4X 6 A	CYL.HEAD SCREW DIN0084-M 4X 6A	1
20	440.11.076.100	KABELBAND 100MM	CABLE TIE 100MM	X
29	490.30.090.000	PASSHÜLSE 9,8 X 7 X 10	DOWEL 9,8 X 7 X 10	2
30	0015 060353	SK.BUNDSCHRAUBE M 6X35 SW=8	HH COLLAR SCREW M 6X35 WS=8	2
31	0015 060303	SK.BUNDSCHRAUBE M 6X30 SW=8	HH COLLAR SCREW M 6X30 WS=8	2
32	0015 060203	SK.BUNDSCHRAUBE M 6X20 SW=8	HH COLLAR SCREW M 6X20 WS=8	2
34	0015 050163	SK.BUNDSCHRAUBE M 5X16 SW=8	HH COLLAR SCREW M 5X16 WS=8	2
35	0014 060203	SK.BUNDSCHRAUBE M 6X20 SW=8	HH COLLAR SCREW M 6X20 WS=8	2
36	0015 060163	SK.BUNDSCHRAUBE M 6X16 SW=8	HH COLLAR SCREW M 6X16 WS=8	2

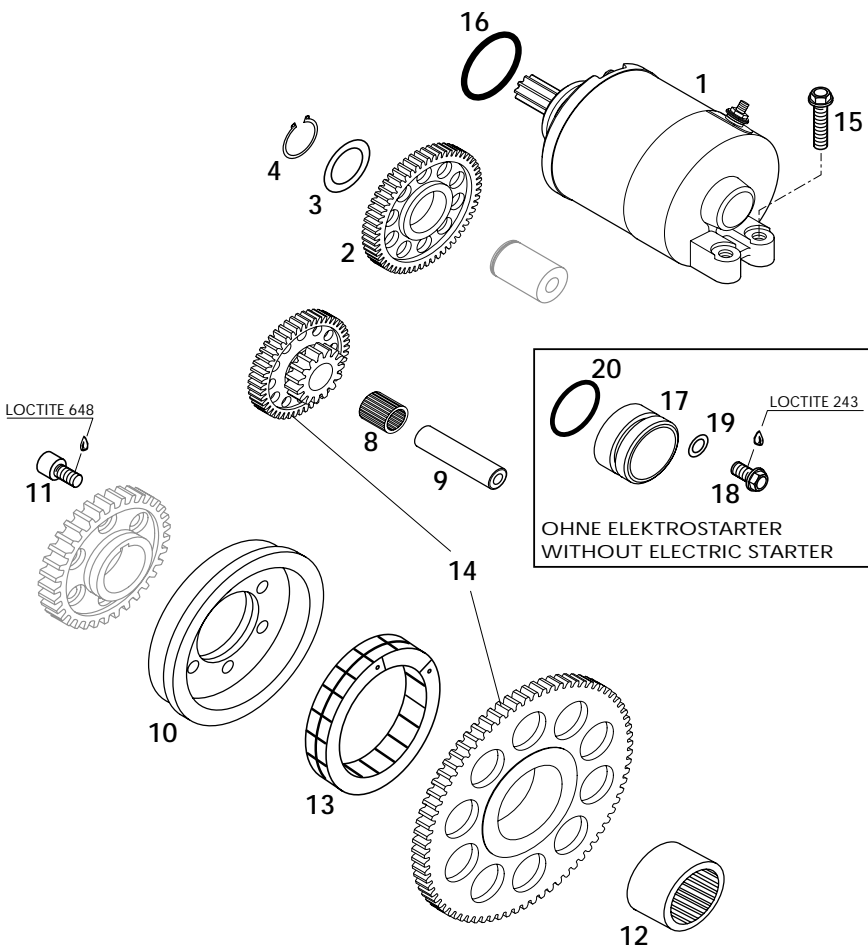

FIG	TEILNR/PARTNR	BEZEICHNUNG	DESCRIPTION	QTY
1	590.40.001.000	E-STARTERMOTOR KPL. 0,45 KW	E-STARTER ENGINE KPL. 0,45 KW	1
2	590.40.022.058	ZWISCHENZAHRAD 58-Z	INTERMEDIATE GEAR 58-T	1
3	546.33.090.000	ANLAUFSCHLEIBE 17,2X25X1	STOP DISK 17,2X24X1	1
4	0471 170010	SICHERUNGSRING DIN0471-17X1	CIRCLIP DIN0471-17X1	1
8	0405 101316	NADELKRANZ K 10X13X16 TN	NEEDLE BEARING K 10X13X16 TN	1
9	590.40.029.000	LAGERBOLZEN	BEARING BOLT 5X10X47	1
10	590.40.025.000	FREILAUFNABE	FREE WHEEL HUB	1
11*	0912 060106	ISK.SCHR. DIN0912-M 6X10 10.9	AH SCREW DIN0912-M 6X10 10.9	6
12	0618 301617	NADELHÜLSE HK 3016 B	NEEDLE BEARING HK 3016 B	1
13	584.40.026.000	FREILAUF FWD 332008 BLS	FREE-WHEEL FWD 332008 BLS	1
14*	590.40.020.144	FREILAUF+DOPPELZAHN.75-48/15-Z	FREE WHEEL+REDUCT.G.75-48/15-Z	1
15	0015 060203	SK.BUNDSCHRAUBE M 6X20 SW=8	HH COLLAR SCREW M 6X20 WS=8	2
16	0770 250030	O-RING 25,00X3,00 NBR 70	O-RING 25,00X3,00 NBR 70	1
17	590.40.034.000	VERSCHLUSSDECKEL	CAP COVER 30X20XMM	1
18	0015 060123	SK.BUNDSCHRAUBE M 6X12 SW=8	HH COLLAR SCREW M 6X12 WS=8	1
19	0125 060003	UNTERLEGSCHLEIBE DIN0125-A 6,4	WASHER DIN0125-A 6,4	1
20	0770 250030	O-RING 25,00X3,00 NBR 70	O-RING 25,00X3,00 NBR 70	1

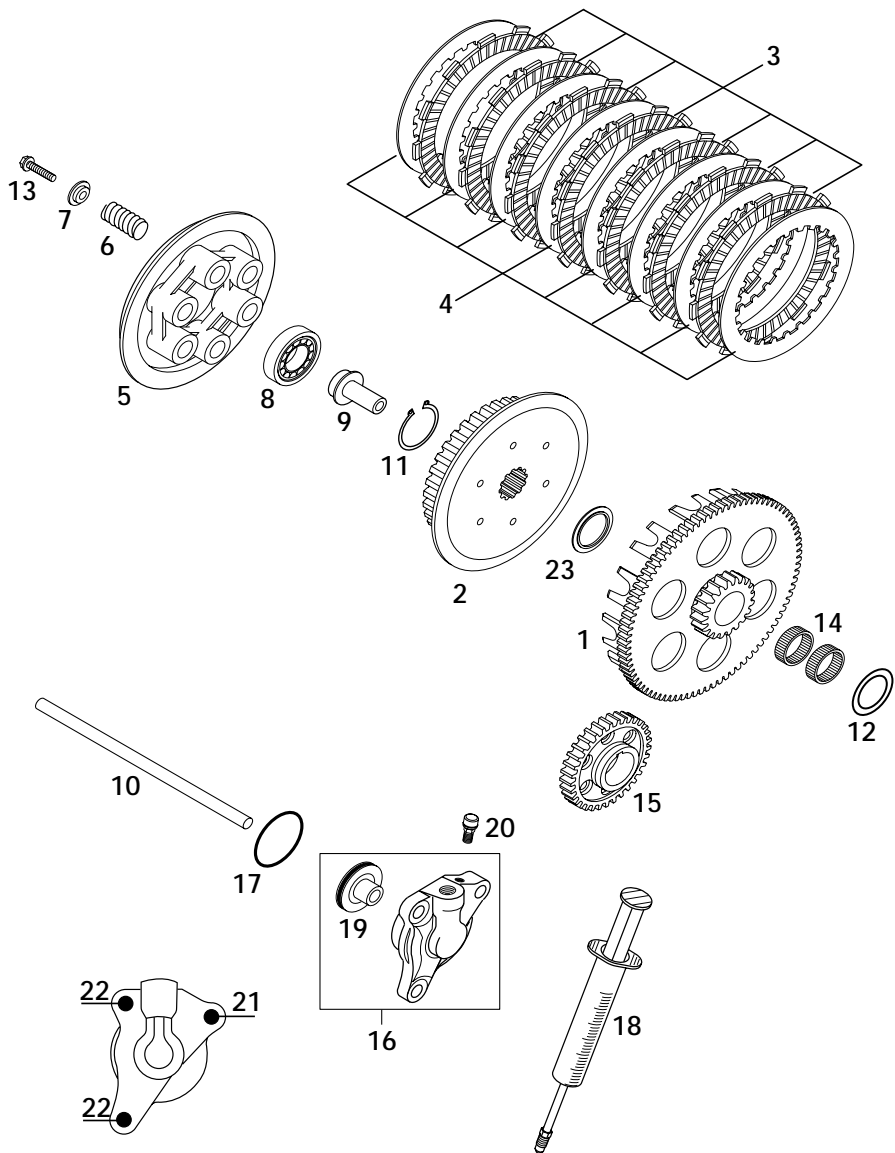

FIG	TEILNR/PARTNR	BEZEICHNUNG	DESCRIPTION	QTY
1*	590.32.000.276	KUPPLUNGSKORB 76-Z/20-Z EINSATZ GEHÄRTET	OUTER CLUTCH H. 76-T/20-T 2001 HARDED	1
2*	590.32.002.000	MITNEHMER RACING	INNER CLUTCH HUB RACING	1
3	590.32.011.000	BELAGLAMELLE 1,8MM	LINING DISK 1,8MM	7
4	590.32.010.000	ZWISCHENLAMELLE 1MM	INTERMEDIATE DISC 1MM	8
5	590.32.003.000	DRUCKKAPPE	PRESSURE CAP	1
6	590.32.005.000	KUPPLUNGSFEDER 2,5X43MM	CLUTCH SPRING 2,5X43MM	6
7	590.32.006.000	FEDERTELLER 6,2X12X18X3,6	SPRING RETAINER 6,2X12X18X3,6	6
8	0625 160040	RILLENKUGELLAGER TM 16004 C3	GROOVED BALL BEARING 16004 C3	1
9	590.32.055.000	AUFLAGEBOLZEN	PRESSURE BOLT 7X12X40	1
10	590.32.054.000	DRUCKSTANGE 7X188MM	PUSH ROD 7X188MM	1
11	0471 250120	SICHERUNGSRING DIN0471-25X1,2	CIRCLIP DIN0471-25X1,2	1
12	590.32.017.000	STÜTZSCHEIBE 25X35X1	SUPPORTWASHER 25X35X1	1
13	0015 060253	SK.BUNDSCHRAUBE M 6X25 SW=8	HH COLLAR SCREW M 6X25 WS=8	6
14*	0405 252910	NADELKRAUZ K 25X29X10	NEEDLE BEAR K25X29X10	2
15	590.32.000.033	PRIMÄRRAD 33-Z	PRIMARY GEAR 33-T	1
16	547.32.061.044	NEHMERZYLINDER KPL. 250-380'99	CYLINDER CPL. 250-380 '99	1
17	0770 300015	O-RING 30,00X1,50 NBR 70	O-RING 30,00X1,50 NBR 70	1
18	503.29.050.000	ENTLÜFT.SPRITZE HYDR. KUPPLUNG	VENT INJEKTION HYDR. CLUTCH	1
19	546.32.066.000	KOLBEN MIT O-RING 250-380'2000	PISTON W. O-RING 250-380 '2000	1
20	547.32.064.000	ENTLÜFTUNGSSCHR. MIT KAPPE	BLEEDER SCREW WITH CAP	1
21	0015 060353	SK.BUNDSCHRAUBE M 6X35 SW=8	HH COLLAR SCREW M 6X35 WS=8	1
22	0015 060203	SK.BUNDSCHRAUBE M 6X20 SW=8	HH COLLAR SCREW M 6X20 WS=8	2
23*	590.32.014.000	STUFENSCHLEIBE	WASHER	1

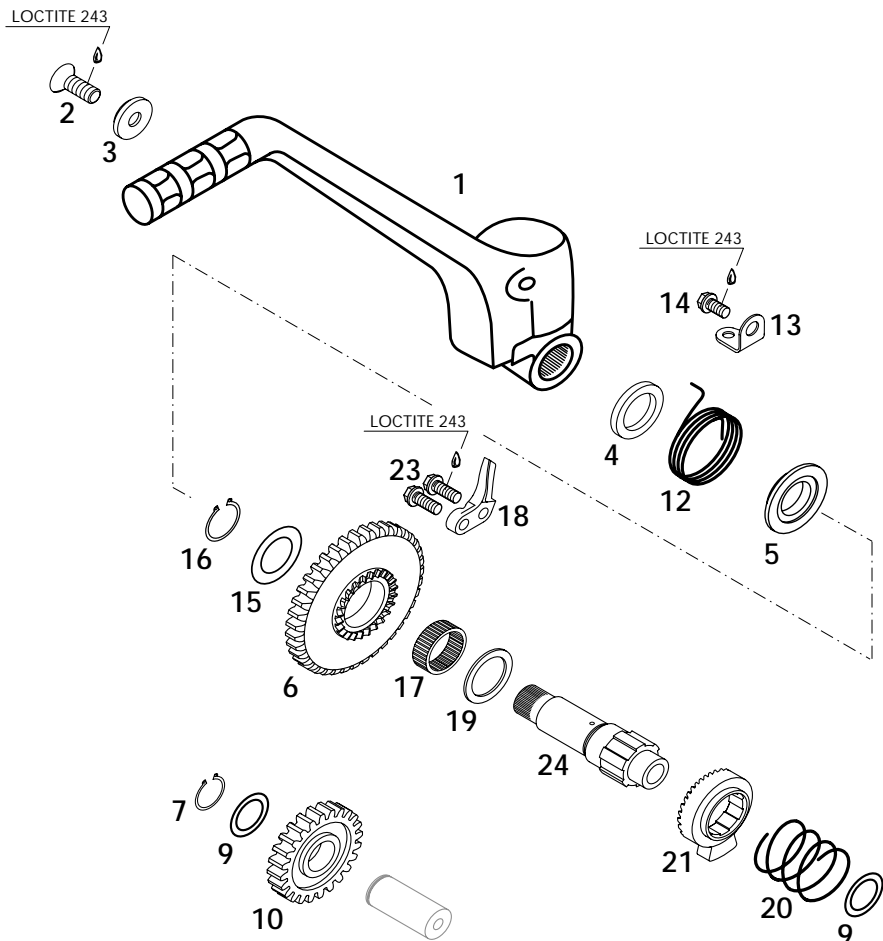

FIG	TEILNR/PARTNR	BEZEICHNUNG	DESCRIPTION	QTY
1	590.33.070.044	KICKSTARTER KPL.	KICKSTARTER CPL. RACING 2000	1
2	546.10.052.000	KETTENRADSCHRAUBE-ISK M 8X20	SPROCKET SCREW-AH M 8X20	1
3	546.33.037.000	FASSONSCHIBE 8 MM VERZINKT	WASHER D=8MM	1
4	0760 193070	WELLENDICHTRING 19X30X7 B	SHAFT SEAL RING 19X30X7B	1
5	590.33.055.000	MITNEHMERNABE	DRIVING HUB RACING 2000	1
6	590.33.051.039	STARTERRAD 39-Z	KICKSTARTER GEAR 39-T	1
7	0471 170010	SICHERUNGSRING DIN0471-17X1	CIRCLIP DIN0471-17X1	1
9	0988 172405	PASSSCHEIBE DIN0988-17X24X0,5	SHIM WASHER DIN0988-17X24X0,5	2
10	590.33.053.000	STARTERZWISCHENRAD 24-Z	INTERMEDIATE GEAR 24-T	1
12	590.33.054.000	KICKSTARTFEDER	KICKSTARTER SPRING 2,5MM	1
13	590.33.074.000	FEDERLASCHE	SPRING HANGER	1
14	0015 060123	SK.BUNDSCHRAUBE M 6X12 SW=8	HH COLLAR SCREW M 6X12 WS=8	1
15	590.33.080.000	SCHEIBE 20X32X1	SHIM 20X32X1	1
16	0471 190120	SICHERUNGSRING DIN0471-19X1,2	CIRCLIP DIN0471-19X1,2	1
17	0405 222610	NADELKRANZ K 22X26X10 A	NEEDLE BEARING K 22X26X10 A	1
18	590.33.069.000	ANSCHLAGSTÜCK	BUMP PART	1
19	580.33.031.000	ANLAUFSCHIBE 22,2 X 30 X 1,5	STOP DISK 22 X 30 X 1,5	1
20	580.33.028.000	SPERRADFEDER 1,2 MM	RATCHET GEAR SPRING 1,2 MM	1
21	590.33.052.000	SPERRAD	RATCHET GEAR KICKSTARTER	1
23	0015 060203	SK.BUNDSCHRAUBE M 6X20 SW=8	HH COLLAR SCREW M 6X20 WS=8	2
24	590.33.050.000	KICKSTARTERWELLE RACING 2000	KICKSTARTER SHAFT RACING 2000	1

FIG	TEILNR/PARTNR	BEZEICHNUNG	DESCRIPTION	QTY
1*	590.33.001.100	ANTRIEBSWELLE-ZB 16-Z SX	MAIN SHAFT-ZB 16-T SX	1
2*	590.33.032.100	DISTANZBÜCHSE 25X30X24,4	SPACER BUSHING 25X30X24,4	2
3	0625 062034	RILLENKUGELLAGER 6203 C3 NTN	BALL BEARING 6203 C3 NTN	1
4*	590.33.003.046	SCHIEBERRAD 3/4G. 20/22-Z „46“	SLIDING GEAR 3/4.G 20/22-T“46“	1
6*	590.33.002.037	FESTRAD 2.G 18-Z „37“	SOLID GEAR 2.G 18-T „37“	1
7*	560.33.030.000	ANLAUFSCHIBE 17,2X30X1	STOP DISK 17,2X30X1	1
8	0625 062054	RILLENKUGELLAGER 6205 C3 NTN	BALL BEARING 6205 C3 NTN	1

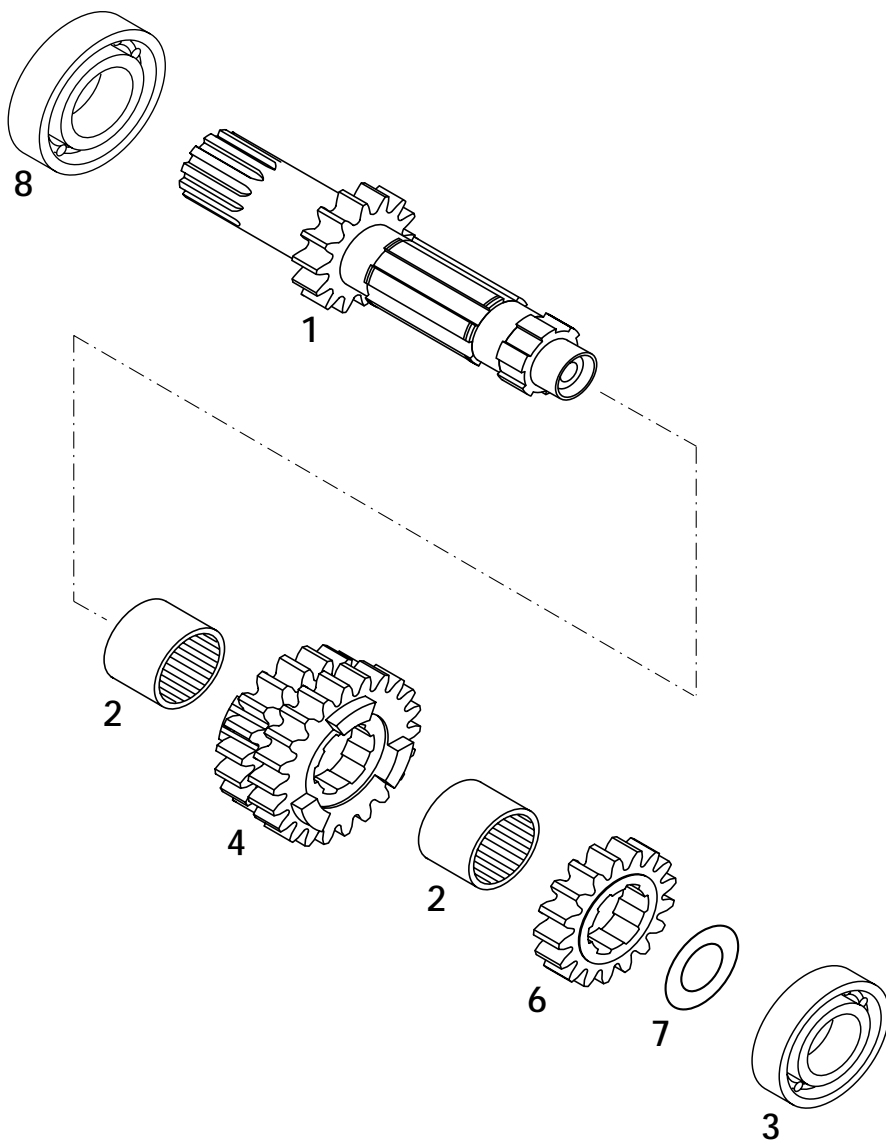

FIG	TEILNR/PARTNR	BEZEICHNUNG	DESCRIPTION	QTY
1*	590.33.001.200	ANTRIEBSWELLE-ZB 14-Z	MAIN SHAFT-ZB 14-T	1
2	590.33.005.034	LOSRAD 5.G 24-Z „34“	IDLER GEAR 5.G 24-T „34“	1
3	565.33.099.000	NADELKRANZ K22X26X13 GETEILT	NEEDLE BEAR. K22X26X13 DIVIDED	2
4	590.33.031.000	ANLAUFSCHLEIBE 25,2X32X1,5	STOP DISK 25,2X32X1,5	1
5	590.33.003.032	SCHIEBERRAD 3/4.G 19/22-Z „32“	SLIDING GEAR 3/4.G 19/22-T „32“	1
6	0471 250120	SICHERUNGSRING DIN0471-25X1,2	CIRCLIP DIN0471-25X1,2	2
7	590.33.030.000	ANLAUFSCHLEIBE 25,2X32X1,5	STOP DISK 25,2X32X1,5	1
9	590.33.006.035	LOSRAD 6.G 26-Z „35“	IDLER GEAR 6.G 26-T „35“	1
10	590.33.002.021	FESTRAD 2.G 17-Z „21“	SOLID GEAR 2.G 17-T „21“	1
11*	560.33.030.000	ANLAUFSCHLEIBE 17,2X30X1	STOP DISK 17,2X30X1	1
12	0625 062034	RILLENKUGELLAGER 6203 C3 NTN	BALL BEARING 6203 C3 NTN	1
13	0625 062054	RILLENKUGELLAGER 6205 C3 NTN	BALL BEARING 6205 C3 NTN	1

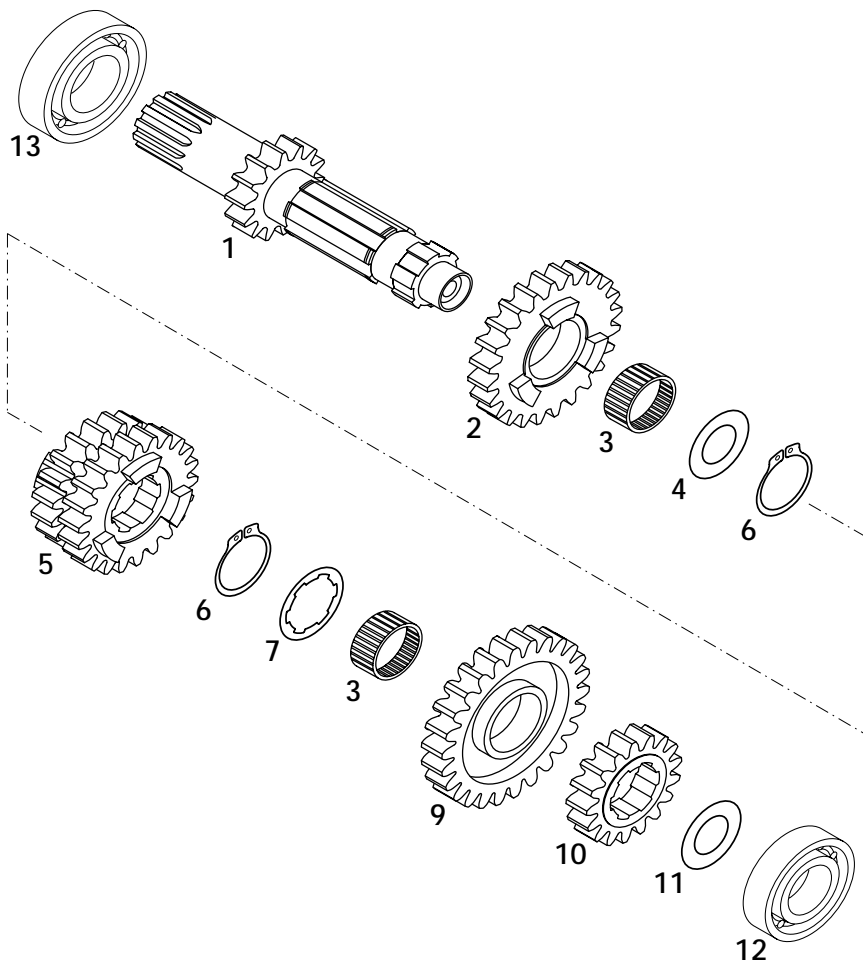
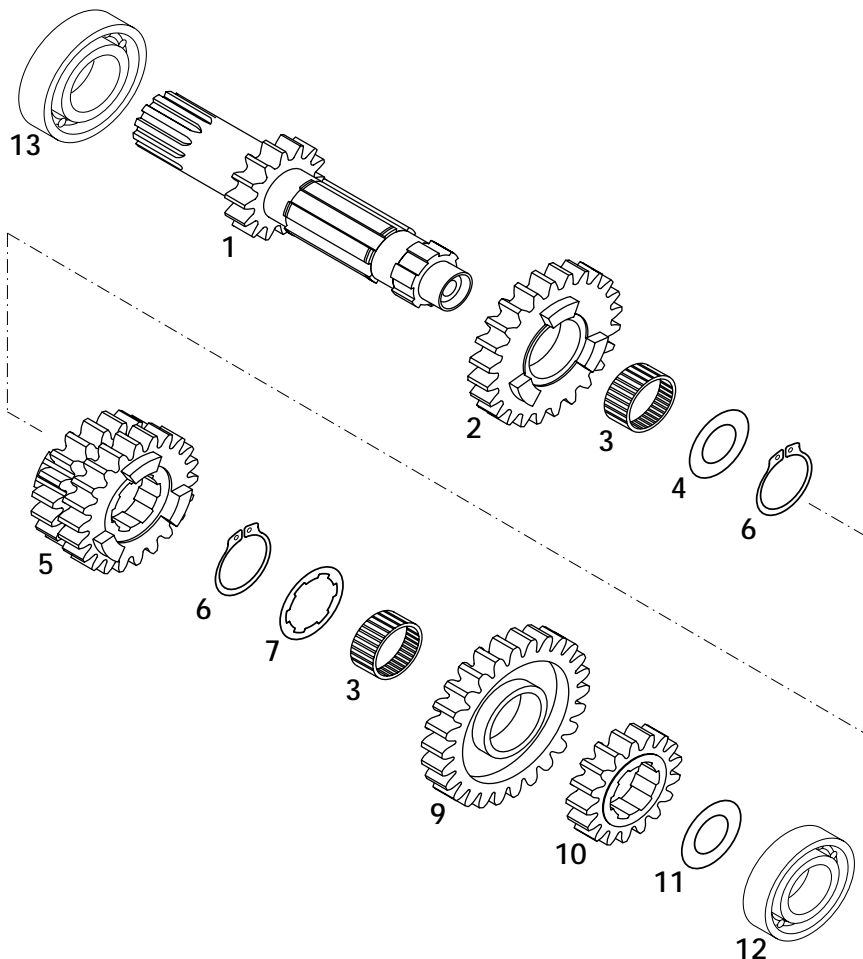

FIG	TEILNR/PARTNR	BEZEICHNUNG	DESCRIPTION	QTY
1*	590.33.001.100	ANTRIEBSWELLE-ZB 16-Z SX	MAIN SHAFT-ZB 16-T SX	1
2*	590.33.005.039	LOSRAD 5.G 24-Z „39“	IDLER GEAR 5.G 24-T „39“	1
3	565.33.099.000	NADELKRANZ K22X26X13 GETEILT	NEEDLE BEAR. K22X26X13 DIVIDED	2
4	590.33.031.000	ANLAUFSCHLEIBE 25,2X32X1,5	STOP DISK 25,2X32X1,5	1
5*	590.33.003.046	SCHIEBERRAD 3/4G. 20/22-Z „46“	SLIDING GEAR 3/4.G 20/22-T „46“	1
6	0471 250120	SICHERUNGSRING DIN0471-25X1,2	CIRCLIP DIN0471-25X1,2	2
7*	590.33.030.000	ANLAUFSCHLEIBE 25,2X32X1,5	STOP DISK 25,2X32X1,5	1
9*	590.33.006.045	LOSRAD 6.G 21-Z „45“	IDLER GEAR 6.G 21-T „45“	1
10*	590.33.002.037	FESTRAD 2.G 18-Z „37“	SOLID GEAR 2.G 18-T „37“	1
11*	560.33.030.000	ANLAUFSCHLEIBE 17,2X30X1	STOP DISK 17,2X30X1	1
12	0625 062034	RILLENKUGELLAGER 6203 C3 NTN	BALL BEARING 6203 C3 NTN	1
13	0625 062054	RILLENKUGELLAGER 6205 C3 NTN	BALL BEARING 6205 C3 NTN	1



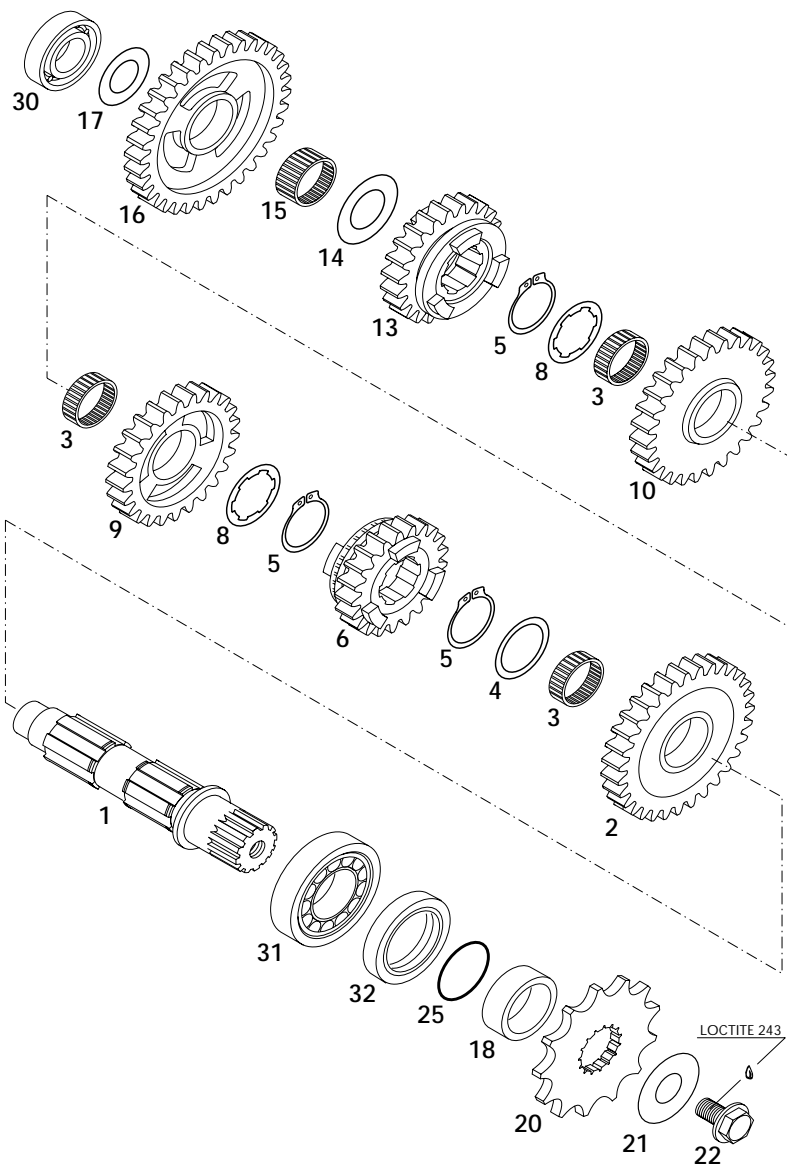

FIG	TEILNR/PARTNR	BEZEICHNUNG	DESCRIPTION	QTY
1	590.33.010.000	ABTRIEBSWELLE RACING 2000	MAIN SHAFT RACING 2000	1
2	590.33.012.025	LOSRAD 2.G 31-Z „25“ 400/520 EXC	IDLER GEAR 2.G 31-T „25“ 400/520 EXC	1
2	590.33.012.036	LOSRAD 2.G 30-Z „36“ 400/520 MXC, 400 SX, 520 SX	IDLER GEAR 2.G 30-T „36“ 400/520 MXC, 400 SX, 520 SX	1
3	0405 222611	NADELKRANZ K 22X26X10 GETEILT	NEEDLE BEAR.K 22X26X10 DIVIDED	3
4	590.33.031.000	ANLAUFSCHIEBE 25,2X32X1,5	STOP DISK 25,2X32X1,5	1
5	0471 250120	SICHERUNGSRING DIN0471-25X1,2	CIRCLIP DIN0471-25X1,2	3
6	590.33.016.026	SCHIEBERRAD 6.G 21-Z „26“ 400/520 EXC, 520 SX	SLIDING GEAR 6.G 21-T „26“ 400/520 EXC, 520 SX	1
6*	590.33.016.044	SCHIEBERRAD 6.G 18-Z „44“ 400/520 MXC, 400 SX	SLIDING GEAR 6.G 18-T „44“ 400/520 MXC, 400 SX	1
8	590.33.030.000	ANLAUFSCHIEBE 25,2X32X1,5	STOP DISK 25,2X32X1,5	2
9	590.33.014.033	LOSRAD 4.G 26-Z „33“	IDLER GEAR 4.G 26-T „33“	1
10	590.33.013.028	LOSRAD 3.G 28-Z „28“ 400/520 EXC	IDLER GEAR 3.G 28-T „28“ 400/520 EXC	1
10*	590.33.013.047	LOSRAD 3.G 28-Z „47“ 400/520 MXC, 400 SX, 520 SX	IDLER GEAR 3.G 28-T „47“ 400/520 MXC, 400 SX, 520 SX	1
13	590.33.015.029	SCHIEBERRAD 5.G 23-Z „29“ 400/520 EXC, 520 SX	SLIDING GEAR 5.G 23-T „29“ 400/520 EXC, 520 SX	1
13*	590.33.015.040	SCHIEBERRAD 5.G 24-Z „40“ 420/520 MXC, 400 SX	SLIDING GEAR 5.G 24-T „40“ 420/520 MXC, 400 SX	1
14	590.33.080.000	SCHEIBE 20X32X1	SHIM 20X32X1	1
15	0405 202612	NADELKRANZ K 20X26X12	NEEDLE BEARING K 20X26X12	1
16	590.33.011.030	LOSRAD 1.G 34-Z „30“ 400/520 EXC	IDLER GEAR 1.G 34-T „30“ 400/520 EXC	1
16*	590.33.011.043	LOSRAD 1.G 32-Z „43“ 400/520 MXC, 400 SX, 520 SX	IDLER GEAR 1.G 32-T „43“ 400/520 MXC, 400 SX, 520 SX	1
17*	560.33.030.000	ANLAUFSCHIEBE 17,2X30X1	STOP DISK 17,2X30X1	1
18	546.33.014.100	DISTANZBÜCHSE 12MM	SPACER BUSHING 12 MM	1
20	500.33.029.013	KETTENRAD 13-Z	SPROCKET 13-T	1
20	500.33.029.014	KETTENRAD 14-Z	SPROCKET 14-T	1
20	500.33.029.015	KETTENRAD 15-Z	SPROCKET 15-T	1
21	590.33.034.000	TELLERFEDER 17,2X40X1,5	SPRING WASHER 17,2X40X1,5	1
22	590.33.029.000	SK.BUNDSCHRAUBE M10X18 SW=17	HH COLLAR SCREW M10X18 WS=17	1
25*	0770 020220	O-RING 25,12X1,78 NBR70	O-RING 25,12X1,78 NBR70	1
30	0625 062034	RILLENKUGELLAGER 6203 C3 NTN	BALL BEARING 6203 C3 NTN	1
31	490.30.023.000	ZYLINDERROLLENLAG. NJ205 C3	CYL.ROLL BEARING NJ205 C3	1
32	0760 324565	WELLENDICHTRING 32X45X6,5 B TSL	SHAFT SEAL RING 32X45X6,5 B TSL	1

* = NEUTEIL / NEW PART X = NACH BEDARF / AS REQUIRED

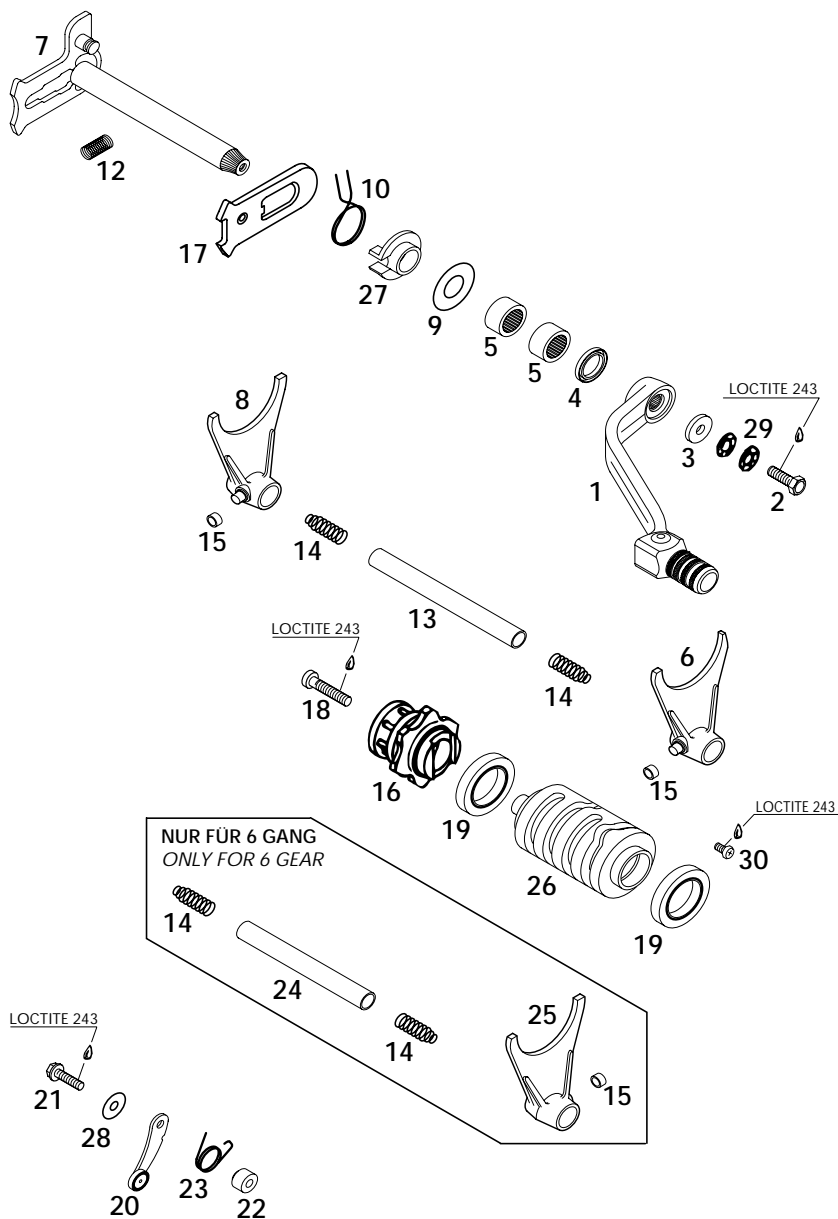

FIG	TEILNR/PARTNR	BEZEICHNUNG	DESCRIPTION	QTY
1	590.34.031.000	SCHALTHEBEL KPL. RACING 2000	SHIFTING LEVER CPL. RACING 2000	1
2	0933 060203	SK.SCHRAUBE DIN0933-M 6X20	HH SCREW DIN0933-M 6X20	1
3	502.32.050.001	STAHLSCHEIBE 6X17X3	STEEL WASHER 6X17X3	1
4	0760 142460	WELLENDICHTRING 14X24X6 B	SHAFT SEAL RING 14X24X6 B	1
5	546.32.095.000	NADELHÜLSE HK 1412 14,6X20X12	NEEDLE BEAR. HK 1412 14,6X20X12	2
6	590.34.002.000	SCHALTGABEL 2./4.GANG 2000	SHIFT FORK 2./4.GEAR 2000	1
7	590.34.005.000	SCHALTWELLE KPL. RACING 2000	SHIFT SHAFT CPL. RACING 2000	1
8	590.34.003.000	SCHALTGABEL 1./3.GANG 2000	SHIFT FORK 1./3.GEAR 2000	1
9	546.34.050.000	ANLAUFSCHLEIBE 14X30X1	STOP DISK 14X30X1	1
10	546.34.014.100	RÜCKHOLFEDER 2,2MM '95	RETURN SPRING 2,2MM '95	1
12	565.34.013.100	SPANNFEDER 0,8MM	SPANNER SPRING 0,8MM	1
13	590.34.020.000	SCHALTSCHIENE ABT. 11,8X105MM	SHIFT RAIL 11,8X105MM	1
14	580.38.023.200	DRUCKFEDER 0,9MM	PRESSURE SPRING 0,9MM	4
15	503.34.018.100	SCHALTROLLE 6X8X5,2 '98	SHIFTING ROLLER 6X8X5,2 '98	3
16	590.34.015.044	SCHALTARRETIERUNG ALU KPL. 2000	SHIFT LOCATING DRUM CPL. 2000	1
17	546.34.008.000	GLEITBLECH	SLIDING PLATE	1
18	0984 060300	ZYL.SCHRAUBE DIN7984-M 6X30	AH SCREW DIN7984-M 6X30	1
19	0625 618050	RILLENKUGELLAGER 61805 C3	BALL BEARING 61805 C3	2
20	546.34.024.144	ARRETIERHEBEL KPL. '96	LOCKING LEVER CPL '96	1
21	0015 050203	SK.BUNDSCHRAUBE M 5X20 SW=8	HH COLLAR SCREW M 5X20 WS=8	1
22	546.34.052.300	HÜLSE FÜR ARRETIERHEBEL	SLEEVE FOR LOCKING LEVER	1
23	590.34.023.000	ARRETIERHEBELFEDER 2,3MM	SPRING 2,3MM	1
24	590.34.019.000	SCHALTSCHIENE ANT. 11,8X89MM	SHIFT RAIL 11,8X89MM	1
25	590.34.001.000	SCHALTGABEL 5./6.GANG 2000	SHIFT FORK 5./6.GEAR 2000	1
26	590.34.012.000	SCHALTWALZE 6-GANG	SHIFTROLLER 6-GEAR	1
26	590.34.012.044	SCHALTWALZE 4-GANG	SHIFTROLLER 4-GEAR	1
27	546.34.020.000	FEDERFÜHRUNG	SPRING GUIDE	1
28	710.08.012.000	SCHEIBE 5,3X17X1,5MM	WASHER 5,3X17X1,5MM	1
29	502.33.041.000	NORDLOCK SCHEIBEN M6 (PAAR)	PAIR OF WASHERS M6 NORDLOCK	2
30	0985 050083	LINSENSCHRAUBE DIN7985-M 5X 8	FLAT HEAD SCREW DIN7985-M 5X 8	1

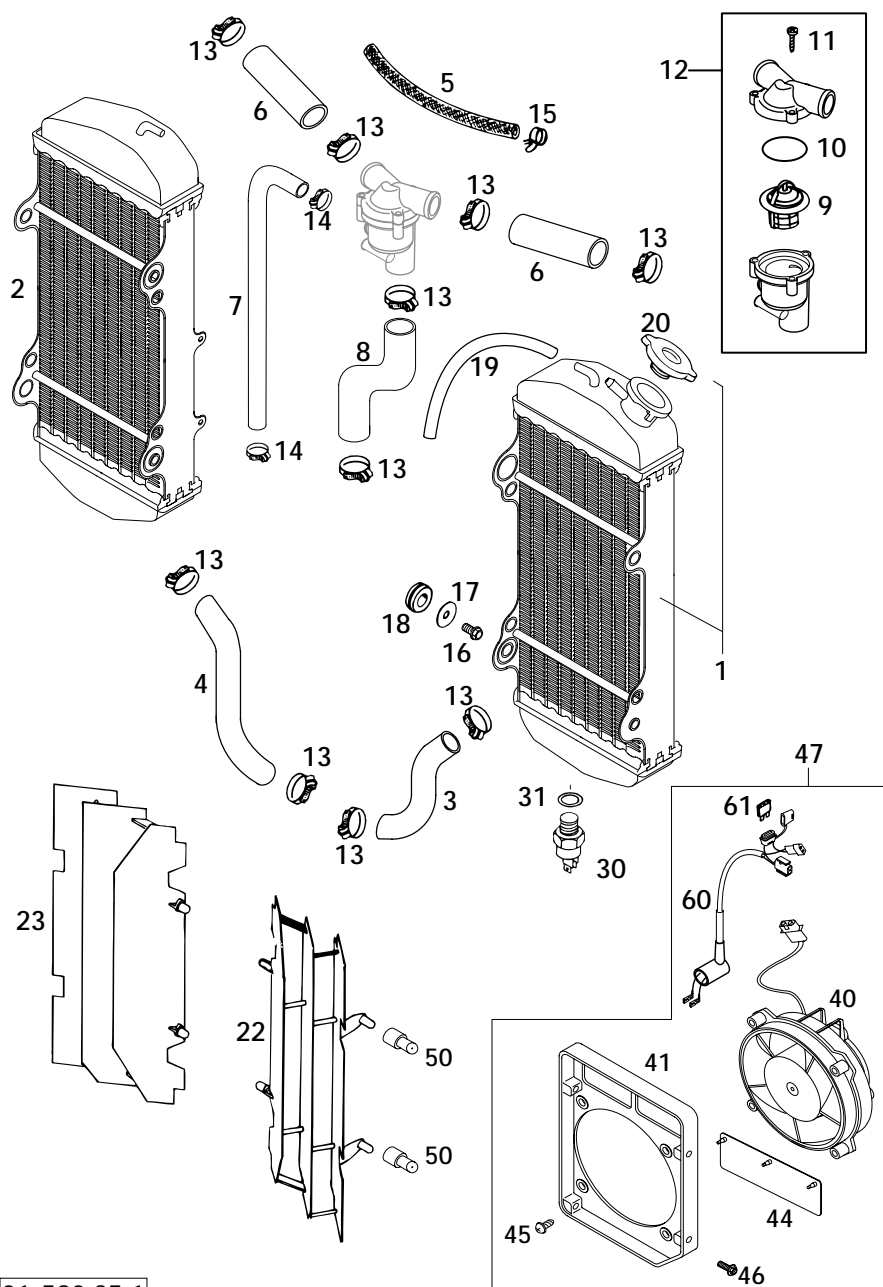

FIG	TEILNR/PARTNR	BEZEICHNUNG	DESCRIPTION	QTY
1*	590.35.007.200	KÜHLER LINKS 45351U 2001	RADIATOR L/S 45351U 2001	1
2*	590.35.008.200	KÜHLER RECHTS 45352U 2001	RADIATOR R/S 45352U 2001	1
3	590.35.024.000	KÜHLERSCHLAUCH LI. KÜHLER-ZYL.	RADIATORHOSE L/S RADIATOR-CYL.	1
4	590.35.124.000	KÜHLERSCHLAUCH RE. KÜHLER-ZYL.	RADIATORHOSE R/S RADIATOR-CYL.	1
5	544.35.024.001	ND-SCHLAUCH ID 7,5 PER METER	HOSE ID 7,5 PER METER	0,19
6	590.35.126.000	KÜHLERSCHLAUCH KÜHLER-THERMO.	RADIATOR HOSE RADIATOR-THERMO.	2
7	590.35.025.001	KÜHLERGEWEBESCHLAUCH SEKUNDÄR. KÜHLER-THERMOSTAT	RADIATOR HOSE SECONDARY RADIATOR-THERMOSTAT	1
8	590.35.025.000	KÜHLERSCHLAUCH THERMOSTAT-KOPF	RADIATOR HOSE THERMO.-HEAD	1
9	583.35.017.000	THERMOSTAT 70 GRAD '94	THERMOSTAT 70 DEGREES '94	1
10	0770 320020	O-RING 32,00X2,00	O-RING 32,00X2,00	1
11	0016 040183	KUNSTSTOFFSCHR. KB40X18 WN1412	PLASTIC SCREW KB40X18 WN1412	3
12	590.35.013.044	THERMOSTAT KPL. RACING 2000	THERMOSTAT CPL. RACING 2000	1
13	100.01.020.000	SCHLAUCHKLEMME GEMI 16/27	HOSE CLAMP GEMI 16/27	10
14	583.35.099.000	SCHLAUCHBINDER GEMI 10-16	HOSE CLAMP GEMI 10-16	2
15	502.31.005.000	YDNAC - KLAMMER 10119	HOSE CLAMP YDNAC 10119	2
16	0015 060123	SK.BUNDSCHRAUBE M 6X12 SW=8	HH COLLAR SCREW M 6X12 WS=8	4
17	0021 060003	SCHEIBE DIN9021-A 6,4	WASHER DIN9021-A 6,4	4
18	410.01.052.000	KABELTÜLLE D=12MM	RUBBER SLEEVE D=12MM	4
19	550.07.016.001	SCHLAUCH 7X10 PER METER	PVC-HOSE 7X10 PER METER	0,4
20	580.35.016.000	KÜHLERVERSCHLUSS KLEIN 1,4 BAR	RADIATOR CAP SMALL 1,4 BAR	1
22	546.35.034.200	KÜHLERSCHUTZ LINKS FARBLOS '95	RADIATOR PROTECT. L/S WHITE '95	1
23	546.35.134.200	KÜHLERSCHUTZ RECHTS FARBLOS '95	RADIATOR PROTECT. R/S WHITE '95	1
30*	580.35.045.000	THERMOSCHALTER 80-85 GRAD '94	THERMOSWITCH 80-85 DG '94	1
31*	0603 142015	ALU-DICHTRG. DIN7603-14X20X1,5	ALU SEALRING DIN7603-14X20X1,5	1
40*	584.35.041.000	LÜFTER KPL. 12V LC4 2000	FAN CPL. 12V LC4 2000	X
41*	590.35.044.000	LÜFTERHAUBE 2001	FAN CAP 2001	X
44*	584.35.044.050	LÜFTERKLAPPE GUMMI LC4 2000	FAN FLAP RUBBER LC4 2000	X
45*	0081 500181	EJOT PT SCHRAUBE KA50X18WN1411	EJOT PT SCREW KA 50X18 WN1411	X
46*	0017 060203	SONDERSCHRAUBE T60 6X20	SPECIAL SCREW T60 6X20	X
47*	590.35.041.044	LÜFTER KPL. RACING 2001	FAN CPL. RACING 2001	X
50*	546.35.034.050	ADAPTER FÜR KÜHLERSCHUTZ	ADAPTER FOR RADIATOR PROTECTOR	4
60*	590.11.079.000	LÜFTERKABELSTRANG 2001	FAN WIRING HARNESS	X
61*	580.11.109.005	STECKSICHERUNG 5 A	FUSE 5 A	X

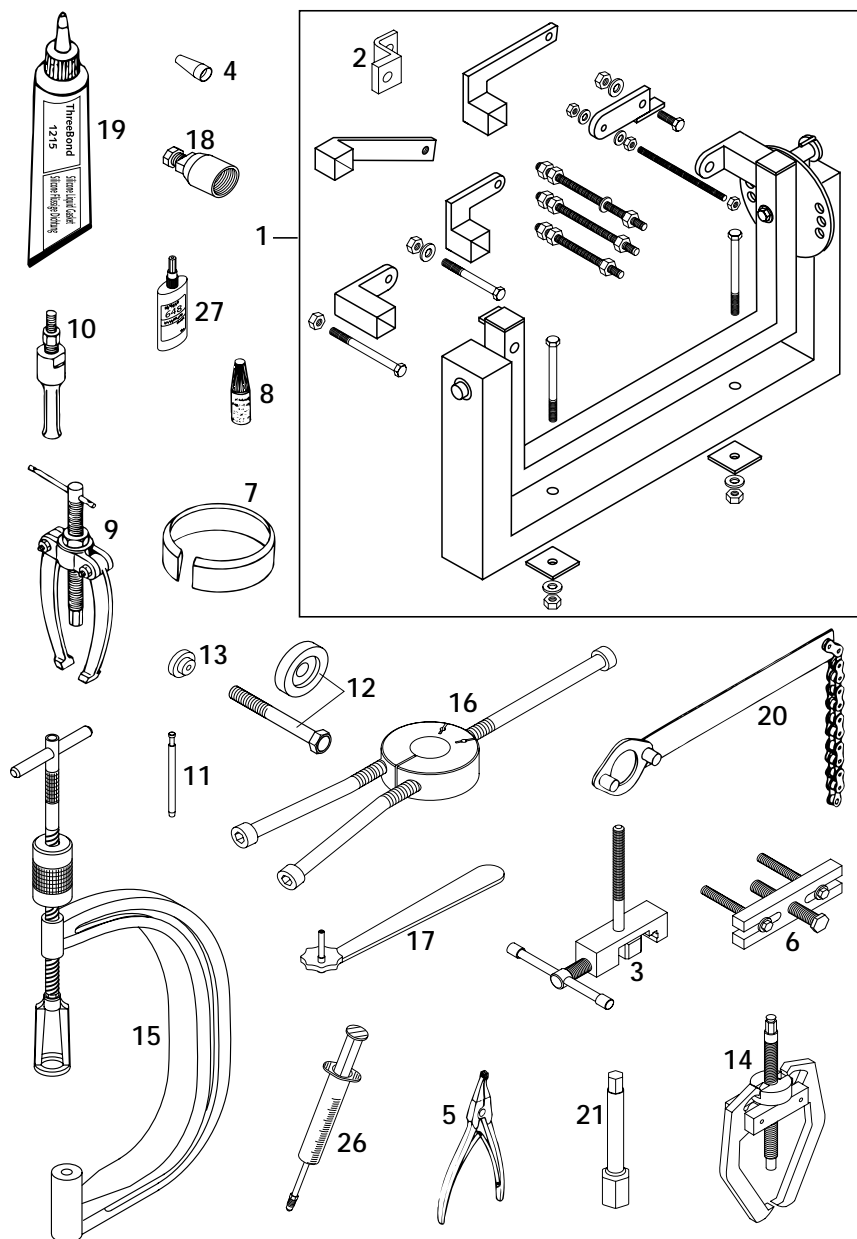

FIG	TEILNR/PARTNR	BEZEICHNUNG	DESCRIPTION	QTY
1	560.12.001.000	UNIVERSALMONTAGEBOCK '96	UNIVERSAL MOUNTING RACK '96	1
2	590.29.002.000	MOTORHALTER FÜR RACING 2000	ENGINE HOLDER FOR RACING 2000	1
3	590.29.020.000	NIETWERKZEUG STEUERKETTE KPL.	RIVETTING TOOL TIMING CHAIN	1
4	590.29.005.010	MONTAGEHÜLSE WELLENDICHTRING F.WASSERPUMP.WELLENDICHTRING	MOUNTING SLEEVE SEAL RING FOR WATER PUMP-SEAL RING	1
5	510.12.011.000	SEEGERRINGZANGE VERKEHRT	SPECIAL CIRCLIP PLIER	1
6	590.29.021.000	ABZIEHER PRIM.RAD-KUPP.MITN.	EXTRACT.PRIM.GEAR-INNER CLUTCH	1
7	580.12.015.089	KOLBEN-MONTAGERING D=89MM	PISTON RING COMPRESSOR D=89MM	1
7	580.12.015.095	KOLBEN-MONTAGERING D=95MM	PISTON RING COMPRESSOR D=95MM	1
8	6 899 785	LOCTITE 243 BLAU 6CCM	LOCTITE 243 BLUE 6CCM	1
9	151.12.017.000	LAGERAUSZIEHER	BEARING EXTRACTOR	1
10	151.12.018.000	EINSATZ 12-16 MM	INTERN.BEAR.PULLER 12-16 MM	1
10	151.12.018.100	EINSATZ 18-23 MM	INTERN.BEAR.PULLER 18-23 MM	1
10	151.12.018.200	EINSATZ 5-7 MM	INTERN.BEAR.PULLER 5-7 MM	1
11	590.29.026.006	GRENZLEHRDORN F.VENTILFÜHRUNG	LIMIT PLUG GAUGE F.VALVE GUIDE	1
12	590.29.035.000	MONTAGERING FÜR MITNEHMER	MOUNTING RING FOR INNER CLUTCH	1
13	590.29.036.000	SCHUTZKAPPE FÜR ANTRIEBSWELLE	PROTECTION COVER F.MAIN SHAFT	1
14	590.29.033.000	ZWEIBACK.ABZIEHER STEUERRITZEL	EXTRACTOR FOR TIMING GEAR	1
15	590.29.019.000	VENTILFEDERHEBER	VALVE SPRING LEVER	1
16	584.29.037.037	MONTAGEW.F.LAGERINNENR. NJ206	MOUNTING TOOL INNER RING NJ206	1
17	590.29.034.000	SCHLÜSSEL GEMISCHREG.SCHRAUBE	WRENCH F.MIXTURE CONTROL SCREW	1
18	580.12.009.000	SCHWUNGRADABZIEHER	FLYWHEEL EXTRACTOR	1
19	309098	SILIKONDICHTMASSE THREE-BOND	SILICON GASKET THREE-BOND	1
20	510.12.012.000	HALTESCHLÜSSEL F. KETTENRITZEL	HOLDING SPANNER FOR SPROCKET	1
21	590.29.072.000	ZÜNDKERZENSCHLÜSSEL 13/16	SPARK PLUG WRENCH 13/16	1
26	503.29.050.000	ENTLÜFT.SPRITZE HYDR. KUPPLUNG	VENT INJEKTION HYDR. CLUTCH	1
27	584.29.059.000	LOCTITE 648 GRÜN 20ML	LOCTITE 648 GREEN 20ML	1

TEILNR/PARTNR	BEZEICHNUNG	DESCRIPTION	QTY
590.12.099.044	WARTUNGSKIT KLEIN 400/520	MAINTENANCE KIT SMALL 400/520	1
590.32.002.044	MITNEHMER	INNER CLUTCH HUB	1
590.32.011.000	BELAGLAMELLE 1,8MM	LINING DISK 1,8MM	7
590.32.010.000	ZWISCHENLAMELLE 1MM	INTERMEDIATE DISK 1MM	8
590.30.025.000	KUPPLUNGSDECKELDICHTUNG 0,5MM	CLUTCH COVER GASKET 0,5MM	1
595.12.099.144	WARTUNGSKIT GROSS 400	MAINTENANCE KIT LARGE 400	1
590.32.002.044	MITNEHMER	INNER CLUTCH HUB	1
590.32.011.000	BELAGLAMELLE 1,8MM	LINING DISK 1,8MM	7
590.32.010.000	ZWISCHENLAMELLE 1MM	INTERMEDIATE DISK 1MM	8
590.36.013.000	STEUERKETTE 97 ROLLEN	TIMING CHAIN 97 ROLLS	1
590.36.003.000	STEUERKETTENSPELLER KPL.	TIMING CHAIN TENSIONER CPL.	1
503.30.082.000	ZYLINDERR.LAGER NJ206 ET2XCS46	CYL.ROLLER BEAR NJ206 ET2XCS46	2
0625.160040	RILLENKUGELLAGER 16004 C3	GROOVED BALL BEARING 16004 C3	2
590.30.099.000	DICHTUNGSSATZ KPL.	GASKET SET CPL.	1
590.12.099.144	WARTUNGSKIT GROSS 520	MAINTENANCE KIT LARGE 520	1
590.32.002.044	MITNEHMER	INNER CLUTCH HUB	1
590.32.011.000	BELAGLAMELLE 1,8MM	LINING DISK 1,8MM	7
590.32.010.000	ZWISCHENLAMELLE 1MM	INTERMEDIATE DISK 1MM	8
590.36.013.000	STEUERKETTE 97 ROLLEN	TIMING CHAIN 97 ROLLS	1
590.36.003.000	STEUERKETTENSPELLER KPL.	TIMING CHAIN TENSIONER CPL.	1
503.30.082.000	ZYLINDERR.LAGER NJ206 ET2XCS46	CYL.ROLLER BEAR NJ206 ET2XCS46	2
0625.160040	RILLENKUGELLAGER 16004 C3	GROOVED BALL BEARING 16004 C3	2
590.30.007.000	KOLBEN 95MM KPL.	PISTON 95MM CPL.	1
590.30.015.044	PLEUELREPERATURSATZ 520	CON.ROD REP. SET 520	1
590.30.099.000	DICHTUNGSSATZ KPL.	GASKET SET CPL.	1

TECHNISCHE DATEN – MOTOR 400/520 SX, MXC, EXC RACING 2001

Motor	400 SX	400 MXC	400 EXC	520 SX	520 MXC	520 EXC
Bauart	1-Zylinder 4-Takt Otto-Motor mit Ausgleichswelle, Flüssigkeitsgekühlt					
Hubraum	398 cm ³		510 cm ³		510 cm ³	
Bohrung/Hub	89 / 64 mm		95 / 72 mm		95 / 72 mm	
Verdichtung	11 : 1					
Kraftstoff	bleifreier Superkraftstoff mit mindestens ROZ 95					
Steuerung	4 Ventile über Kipphebel u. 1 Nockenwelle gesteuert, Antrieb der Nockenwelle mit Einfachkette					
Nockenwelle	0121	Einlaß: 35 mm Auslaß: 30 mm		5521		
Ventildurchmesser						
Ventilspiel kalt	Einlaß: 0,10 mm Auslaß: 0,15 mm		2 Zylinderrollenlager			
Kurbelwellenlagerung	Nadellager					
Pleuellager	Bronzebüchse					
Kolbenbolzenlager	Leichtmetall gegossen		Leichtmetall geschmiedet			
Kolben	1 Kompressionsring, 1 Ölabstreifring					
Kolbenringe	Druckumlaufschmierung mit 2 Rotorpumpen					
Motorschmierung	vollsynthetisches Motoröl (Shell Advance Ultra4 SAE 10W/40)					
Motoröl	1,25 Liter					
Füllmenge Motoröl	gerade verzahnte Stirnräder 33:76 Z					
Primärtrieb	Mehrscheibenkupplung im Ölbad					
Kupplung	6-Gang	6-Gang	6-Gang	4-Gang	6-Gang	6-Gang
Getriebe (Klaugeschaltet)	6-Gang	6-Gang	6-Gang	4-Gang	6-Gang	6-Gang
Getriebeübersetzung	16:32	16:32	14:34	16:32	16:32	14:34
1. Gang	18:30	18:30	17:31	18:30	18:30	17:31
2. Gang	20:28	20:28	19:28	20:28	20:28	19:28
3. Gang	22:26	22:26	22:26	22:26	22:26	22:26
4. Gang	24:24	24:24	24:23	-	24:24	24:23
5. Gang	21:18	21:18	26:21	-	21:18	26:21
6. Gang	kontaktilos gesteuerte DC - CDI Zündanlage mit digitaler Zündverstellung, Typ KOKUSAN					
Zündanlage	12V 40W	12V 110W				
Generator	NGK CR8 EK					
Zündkerze	0,6 mm					
Elektrodenabstand	Flüssigkeitskühlung, permanente Umwälzung der Kühlflüssigkeit durch Wasserpumpe					
Kühlung	1 Liter, Mischungsverhältnis 40% Frostschutz, 60% Wasser, mindestens -25° C					
Kühlflüssigkeit	Kickstarter	Kick-Elektrostarter	Kickstarter	Kickstarter	Kick-	Elektrostarter
Starthilfe						

VERGASER - GRUNDEINSTELLUNG

	400 SX RACING 400 MXC/EXC RACING	400 EXC RACING 12kW 520 EXC RACING 12,5kW	520 MXC/EXC RACING	520 SX RACING
Vergasertyp	MX-FCR39	MX-FCR39	MX-FCR39	MX-FCR39
Regulierungsnummer	031299	130799	100699	250899
Hauptdüse	175	175	175	175
Düsenadel	OBDTM	OB DVR (OBDTM)	OBDTM	OBDTM
Leerlaufdüse	48	48	48	48
Hauptlaufdüse	200	200	200	200
Leerlaufdüse	100	100	100	100
Nadelposition	4. von oben	3. von oben	2. von oben	3. von oben
Startdüse	85	85	85	85
Gemischregulierschraube offen	1	1,25	2,5	1
Schieber	15	15	15	15
Drosselung	-	Schieberanschlag 24,5 mm	-	-
Anschlag Pumpenmembran	055	055	055	055

ANZUGSDREHMOMENTE

SK-Bundschrauben Gehäuse, Kupplungsdeckel, Zündungsdeckel	M6	8 Nm
Ölablaßschraube	M12x1,5	20 Nm
ISK-Verschlußschraube Ölsieb kurz	M16x1,5	10 Nm
SK-Verschlußschraube Ölsieb lang	M20x1,5	15 Nm
Verschlußschraube Überdruckventil	M12x1,5	20 Nm
Düsen-schraube und Hohl-schraube Ölleitung	M8	10 Nm
Schrauben Ölpumpendeckel	M5	Loctite 243 + 6 Nm
SK-Bundschrauben Zylinderkopf-Oberteil, Wasserpumpendeckel	M6	8 Nm
SK-Bundschrauben Auspuffflansch	M6	Loctite 243 + 8 Nm
Zylinderkopfschrauben	M10	40/50 Nm
ISK-Schrauben Nockenwellenrad	M8	Loctite 243 + 28 Nm
Anschlagsschraube Autodeko	M5	Loctite 243 + 6 Nm
ISK-Schrauben Endkappe Kipphebelachse	M5	5 Nm
Kontermutter Ventileinstellschraube	M6x0,75	13 Nm
ISK-Schrauben Primär-rad, Freilauf	M6	Loctite 243 + 18 Nm
SK-Mutter Primär-rad	M20x1,5	Loctite 243 + 150 Nm
ISK-Schrauben Zahnrad Ausgleichswelle	M6	Loctite 243 + 8 Nm
SK-Bundschrauben Kupplungs-federn	M6	8 Nm
ISK-Schraube Schwalzen-arretierung	M6	Loctite 243 + 8 Nm
SK-Bundschraube Arretierhebel	M5	Loctite 243 + 6 Nm
SK-Bundschrauben Ausfallsicherung, Kettenführung, Spannschiene	M6	Loctite 243 + 8 Nm
SK-Bundschrauben Ketten-spanner	M6	8 Nm
SK-Bundschrauben Stator MXX/EXC	M6	Loctite 243 + 8 Nm
SK-Bundschrauben Stator SX	M5	Loctite 243 + 6 Nm
SK-Bundschrauben Impulsgeber	M5	Loctite 243 + 6 Nm
SK-Bundmutter Rotor	M12x1	60 Nm
SK-Bundschraube Anschlagstück Kickstarter	M6	Loctite 243 + 8 Nm
SK-Bundschraube Federlasche Kickstarter	M6	Loctite 243 + 8 Nm
SK-Bundschraube Verschlußdeckel E-Starters, nur SX	M6	Loctite 243 + 8 Nm
SK-Bundschraube Bügel Entlüftungsschlauch	M6	Loctite 243 + 8 Nm
ISK-Schraube Kickstarter	M8	Loctite 243 + 25 Nm
SK-Bundschraube Schalthebel	M6	Loctite 243 + 8 Nm
SK-Schraube Kettenritzel	M10	Loctite 243 + 60 Nm

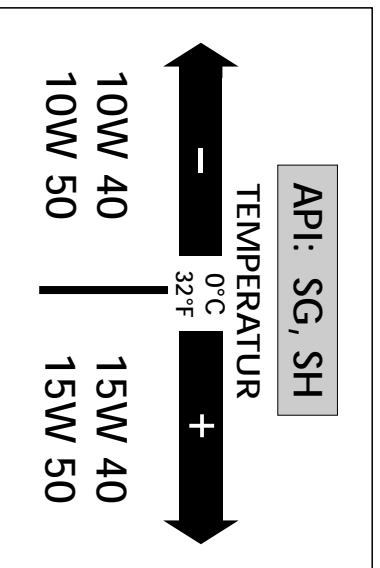

Motoröl

Verwenden Sie nur vollsynthetische Markenöle (Shell Advance Ultra 4), welche die Qualitätsanforderungen der API-Klassen SG oder SH (Angaben auf dem Behälter) erfüllen oder übertreffen.

I VORSICHT I

ZU WENIG MOTORÖL ODER QUALITATIV MINDERWERTIGES ÖL FÜHRT ZU VORZEITIGEM VERSCHLEISS DES MOTORS.

TECHNICAL DATA – ENGINE 400/520 SX, MXC, EXC RACING 2001

Type	400 SX	400 MXC	400 EXC	520 SX	520 MXC	520 EXC
Design	Liquid-cooled single cylinder 4-stroke engine with balancer shaft					
Displacement	398 ccm		510 ccm			
Bore/Stroke	89 / 64 mm		95 / 72 mm			
Ratio	11 : 1					
Fuel	unleaded premium gasoline with at least RON 95					
Valve Timing	4 valves over rocker arm and 1 overhead camshaft, camshaft drive through single chain					
Camshaft	0121		5521			
Valve diameter	Intake: 35 mm		Exhaust: 30 mm			
Valve clearance cold	Intake: 0,10 mm		Exhaust: 0,15 mm			
Crank shaft bearing	2 cylinder roller bearing					
Connecting rod bearing	needle bearing					
Top end bearing	bronze bushing					
Piston	aluminium alloy cast		aluminium alloy forged			
Piston rings	1 compression ring, 1 oil scraper ring					
Engine lubrication	pressure circulation lubrication with two rotorpumps					
Engine oil	fullysynthetic oil (Shell Advance Ultra 4)					
Quantity of engine oil	1,25 liters					
Primary ratio	straight geared spur wheels 33:76 Z					
Clutch	multi disc clutch in oil bath					
Transmission claw shifted	6-speed	6-speed	6-speed	4-speed	6-speed	6-speed
Gear ratio						
1 st Gear	16:32	16:32	14:34	16:32	16:32	14:34
2 nd Gear	18:30	18:30	17:31	18:30	18:30	17:31
3 rd Gear	20:28	20:28	19:28	20:28	20:28	19:28
4 th Gear	22:26	22:26	22:26	22:26	22:26	22:26
5 th Gear	24:24	24:24	24:23	-	24:24	24:23
6 th Gear	21:18	21:18	26:21	-	21:18	26:21
Ignition system	contactless DC-CDI ignition with digital advanced system by KOKUSAN					
Generator	12V 40W	12V 110W				
Spark plug	NGK CR8 EK					
Spark plug gap	0,6 mm					
Cooling system	liquid cooled, permanent rotation of cooling liquid through mechanic driven water pump					
Cooling liquid	1 liter, 40% antifreeze, 60% water, at least -25° (-13° F)					
Starting equipment	kickstarter	kick - electric starter	kickstarter	kickstarter	kick - electric starter	

BASIC CARBURETOR SETTING

	400 SX RACING 400 MXC/EXC RACING	400 EXC RACING (12kW) 520 EXC RACING (12,5kW)	520 MXC/EXC RACING	520 SX RACING
Type	MX-FCR39	MX-FCR39	MX-FCR39	MX-FCR39
Carb. -setting number	031299	130799	100699	250899
Main jet	175	175	175	175
Jet needle	OBDTM	OBDVR (OBDTM)	OBDTM	OBDTM
Idling jet	48	48	48	48
Main air jet	200	200	200	200
Idling air jet	100	100	100	100
Needle clip position	4th from top	3rd from top	2nd from top	3rd from top
Starting jet	85	85	85	85
Mixture control screw open	1	1,25	2,5	1
Throttle valve	15	15	15	15
Performance restrictor	-	slide stop 24,5 mm	-	-
Stop pump membrane	055	055	055	055

TIGHTENING TORQUES

Hexagon collar screw engine case, clutch cover, ignition cover	M6	8 Nm	(6 ft.lb)
Oil drain plug	M12x1,5	20 Nm	(15 ft.lb)
Allan head plug oil screen short	M16x1,5	10 Nm	(7 ft.lb)
Hexagon plug oil screen long	M20x1,5	15 Nm	(11 ft.lb)
Plug pressure valve	M12x1,5	20 Nm	(15 ft.lb)
Jet screw and hollow screw oil line	M8	10 Nm	(7 ft.lb)
Screws oil pump cover	M5	Loctite 243 + 6 Nm	(5 ft.lb)
Hex collar screw cylinderhead top section, water pump cover	M6	8 Nm	(6 ft.lb)
Hexagon collar screw exhaust flange	M6	Loctite 243 + 8 Nm	(6 ft.lb)
Cylinder head screw	M10	40/50 Nm	(30/35 ft.lb)
Allan head screw camshaft gear	M8	Loctite 243 + 28 Nm	(21 ft.lb)
Stop screw autodecompression	M5	Loctite 243 + 6 Nm	(5 ft.lb)
Allan head screw cap rocker arm	M5	5 Nm	(4 ft.lb)
Counter nuts valve adjustment screw	M6x0,75	13 Nm	(10 ft.lb)
Allan head screw primary gear, free wheel	M6	Loctite 243 + 18 Nm	(13 ft.lb)
Hexagon nut primary gear	M20x1,5	Loctite 243 + 150 Nm	(132 ft.lb)
Allan head screw balancer shaft gear	M6	Loctite 243 + 8 Nm	(6 ft.lb)
Hexagon collar screw clutch spring	M6	8 Nm	(6 ft.lb)
Allan head screw shift roller locking piece	M6	Loctite 243 + 8 Nm	(6 ft.lb)
Hexagon collar screw locking lever	M5	Loctite 243 + 6 Nm	(6 ft.lb)
Hexagon collar screw securing guide, chain guide, chain tensioner	M6	Loctite 243 + 8 Nm	(6 ft.lb)
Hexagon collar screw chain adjuster	M6	8 Nm	(6 ft.lb)
Hexagon collar screw stator MXC/EXC	M6	Loctite 243 + 8 Nm	(6 ft.lb)
Hexagon collar screw stator SX	M5	Loctite 243 + 6 Nm	(5 ft.lb)
Hexagon collar screw pulser coil	M5	Loctite 243 + 6 Nm	(5 ft.lb)
Hexagon collar nut flywheel	M12x1	60 Nm	(44 ft.lb)
Hexagon collar screw bump part kickstarter	M6	Loctite 243 + 8 Nm	(6 ft.lb)
Hexagon collar screw spring hanger kickstarter	M6	Loctite 243 + 8 Nm	(6 ft.lb)
Hexagon collar screw cover E-starter, only SX	M6	Loctite 243 + 8 Nm	(6 ft.lb)
Hexagon collar screw hanger vent hose	M6	Loctite 243 + 8 Nm	(6 ft.lb)
Allan head screw kickstarter	M8	Loctite 243 + 25 Nm	(19 ft.lb)
Hexagon collar screw shift lever	M6	Loctite 243 + 8 Nm	(6 ft.lb)
Hexagon screw engine sprocket	M10	Loctite 243 + 60 Nm	(44 ft.lb)

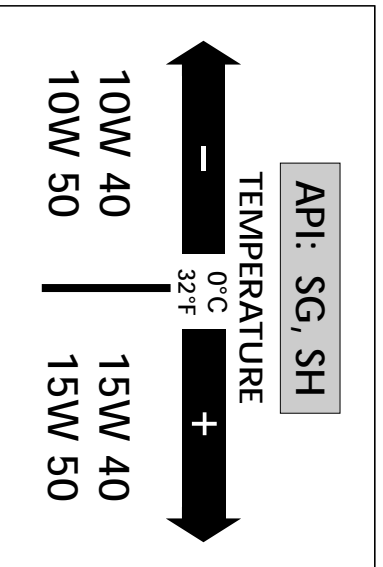

Engine oil

Use only oil brands, which meet quality requirements (Shell Advance Ultra 4) of API-classes SG or SH (Informations on bottles) or higher.

CAUTION

POOR OIL QUALITY OR MINOR QUANTITY EFFECT EARLY ENGINE-WEAR.



KTM SPORTMOTORCYCLE AG
5230 Mattighofen
Austria
Internet: www.ktm.at

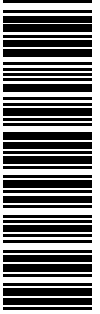

320817