

50 MINI ADVENTURE, 50 JUNIOR ADVENTURE, 50 SENIOR ADVENTURE

KTM
SPORTMOTORCYCLES

ERSATZTEILKATALOG

FAHRGESTELL + MOTOR

SPARE PARTS MANUAL

CHASSIS + ENGINE

2002



TELEGABEL MINI ADVENTURE
FRONT FORK MINI ADVENTURE

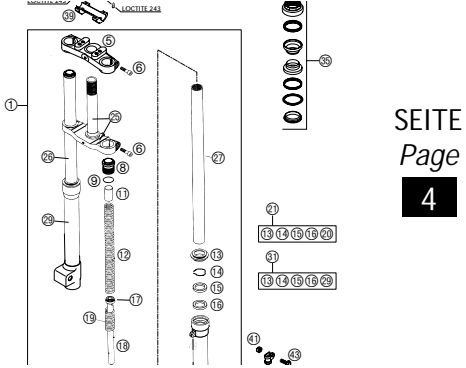

SEITE
Page
4

TELEGABEL JUNIOR ADVENTURE
FRONT FORK JUNIOR ADVENTURE

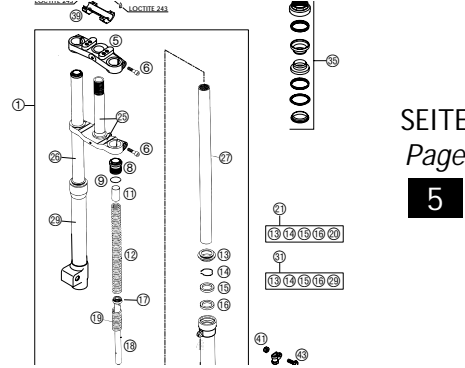

SEITE
Page
5

TELEGABEL SENIOR ADVENTURE
FRONT FORK SENIOR ADVENTURE

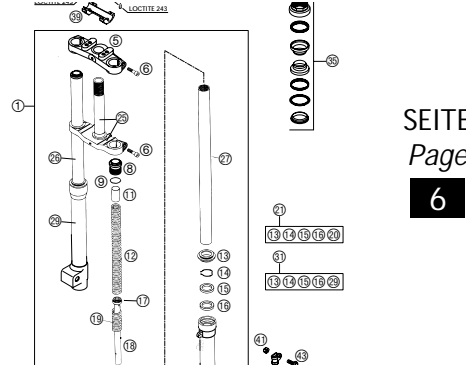

SEITE
Page
6

LENKER, ARMATUREN
HANDLEBAR, CONTROLS

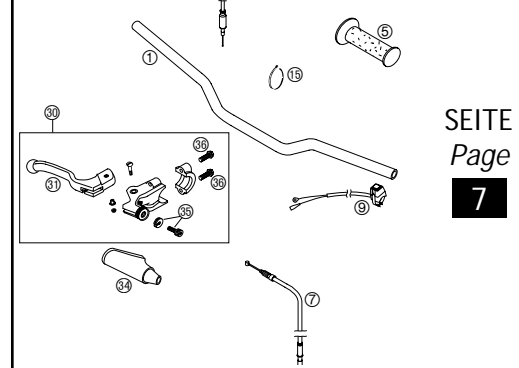

SEITE
Page
7

RAHMEN, SEITENSTÄNDER MINI ADV., JUN. ADV.
FRAME, SIDE STAND MINI ADV., JUN. ADV.

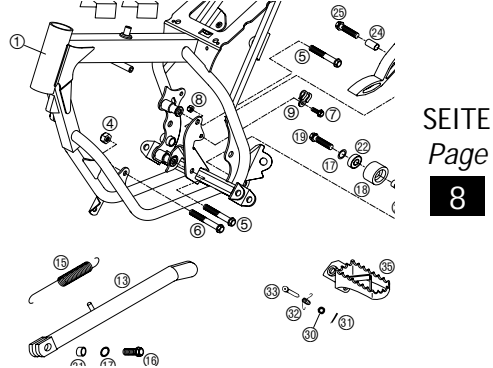

SEITE
Page
8

RAHMEN, SEITENSTÄNDER SENIOR ADV.
FRAME, SIDE STAND SENIOR ADV.

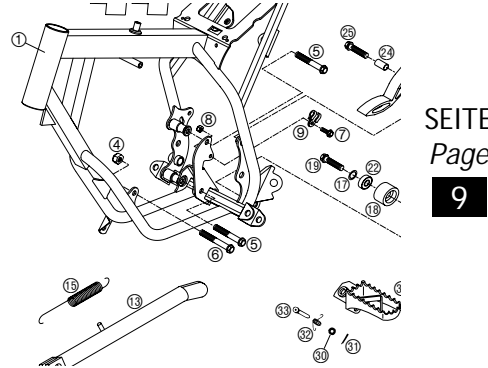

SEITE
Page
9

SCHWINGARM, FEDERBEIN MINI ADV., JUN. ADV.
SWINGARM, SHOCK ABSORBER MINI ADV., JUN. ADV.

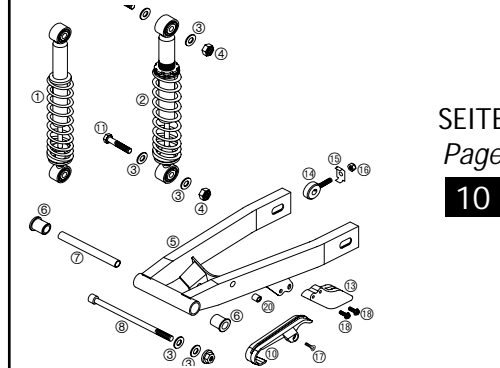

SEITE
Page
10

SCHWINGARM, FEDERBEIN SENIOR ADV.
SWINGARM, SHOCK ABSORBER SEN. ADV.

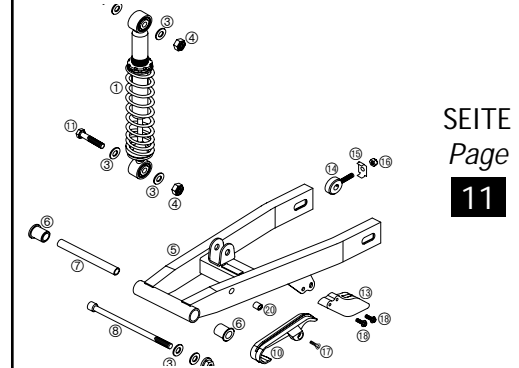

SEITE
Page
11

AUSPUFFANLAGE
EXHAUST SYSTEM



SEITE
Page
12

TANK, SITZBANK, VERKLEIDUNG
TANK, SEAT, COVER

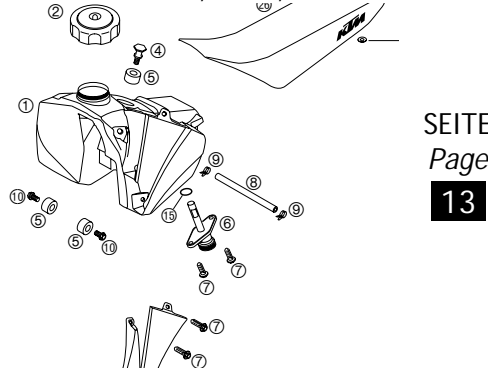

SEITE
Page
13

MASKE, KOTFLÜGEL
MASK, FENDERS

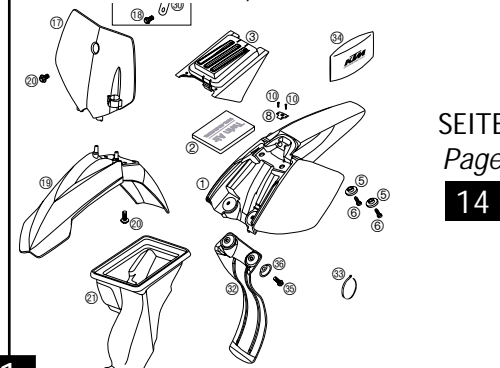

SEITE
Page
14

DEKOR
DECAL



SEITE
Page
15

VORDER- UND HINTERRAD
FRONT- AND REAR WHEEL

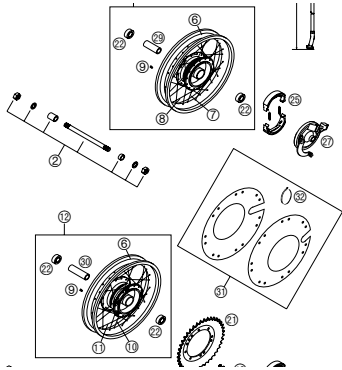

SEITE
Page
16

ZUBEHÖR
ACCESSORIES

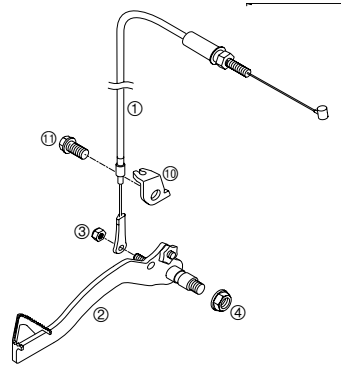

SEITE
Page
17

MOTERGEHÄUSE
ENGINE CASE

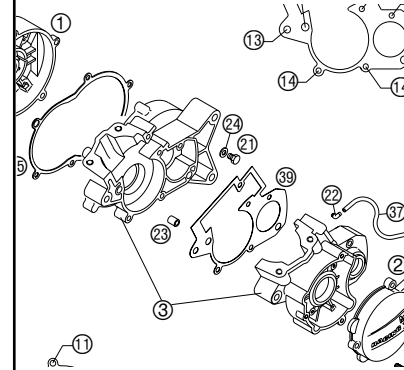

SEITE
Page
18

KURBELWELLE, KOLBEN
CRANKSHAFT, PISTON

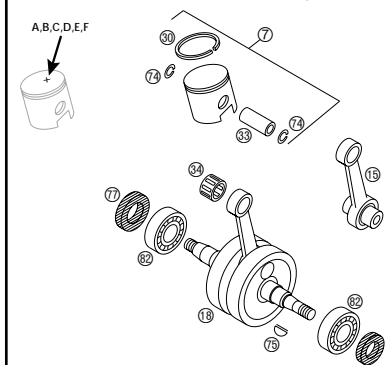

SEITE
Page
19

ZYLINDER, ZYLINDERKOPF
CYLINDER, CYLINDERHEAD

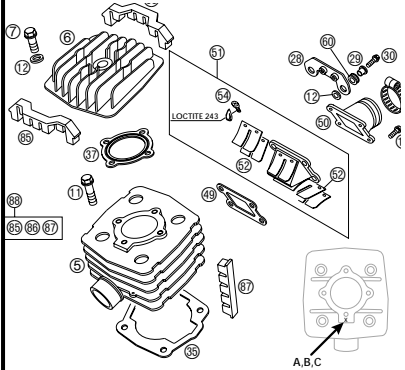

SEITE
Page
20

VERGASER DELLORTO 14 PHVA DS
CARBURETOR DELLORO 14 PHVA DS

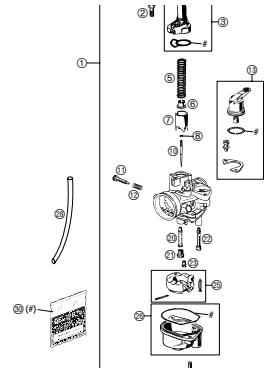

SEITE
Page
21

ZÜNDANLAGE
IGNITION SYSTEM

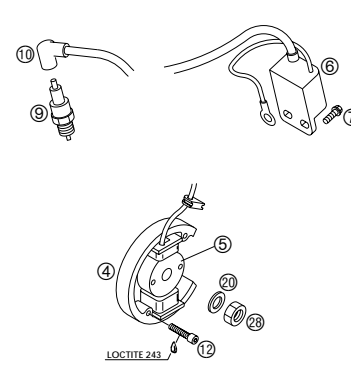

SEITE
Page
22

KUPPLUNG
CLUTCH

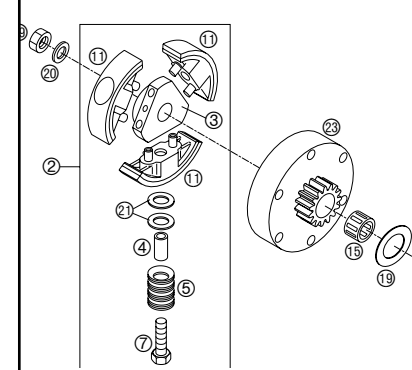

SEITE
Page
23

KICKSTARTER
KICKSTARTER

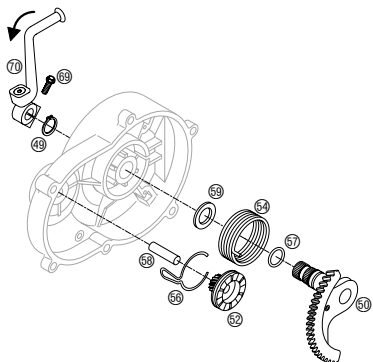

SEITE
Page
24

GETRIEBE
TRANSMISSION

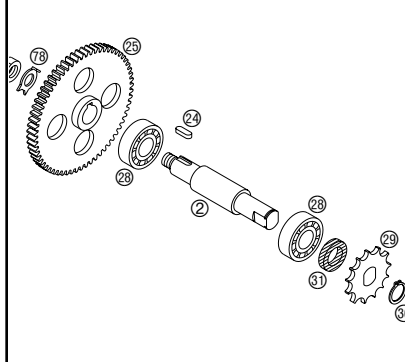

SEITE
Page
25

KICKSTARTER RÜCKWÄRTS
KICKSTARTER BACKWARDS

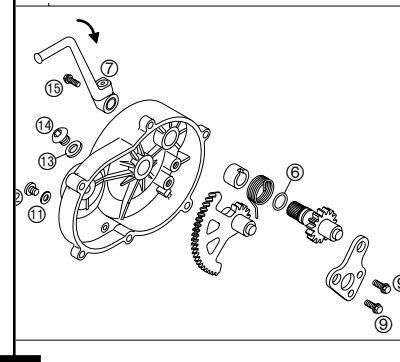

SEITE
Page
26

SPEZIALWERKZEUG
SPECIAL TOOL

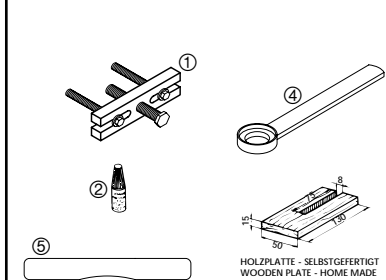

SEITE
Page
27



REG.NO. 12 100 6061

! Die **KTM Sportmotorcycle AG** behält sich das Recht vor, Ausrüstung, technische Angaben, Farben, Materialien, Dienstleistungsangebote, Serviceleistungen und ähnliche Dinge ohne vorheriger Ankündigung und ohne Angabe von Gründen zu ändern bzw. ersatzlos zu streichen, sowie die Fertigung eines bestimmten Modells ohne vorherige Ankündigung einzustellen. Für Druckfehler übernehmen wir keine Haftung.

! **KTM Sportmotorcycle AG** reserves the right to modify any equipment, technical specifications, colors, materials, services offered and rendered, and the like so as to adapt them to local conditions without previous announcement and without giving reasons, or to cancel any of the above items without substituting them with others. It shall be acceptable to stop manufacturing a certain model without previous announcement. In the event of such modifications, please ask your local KTM dealer for information. We shall not be held liable for any printing errors.

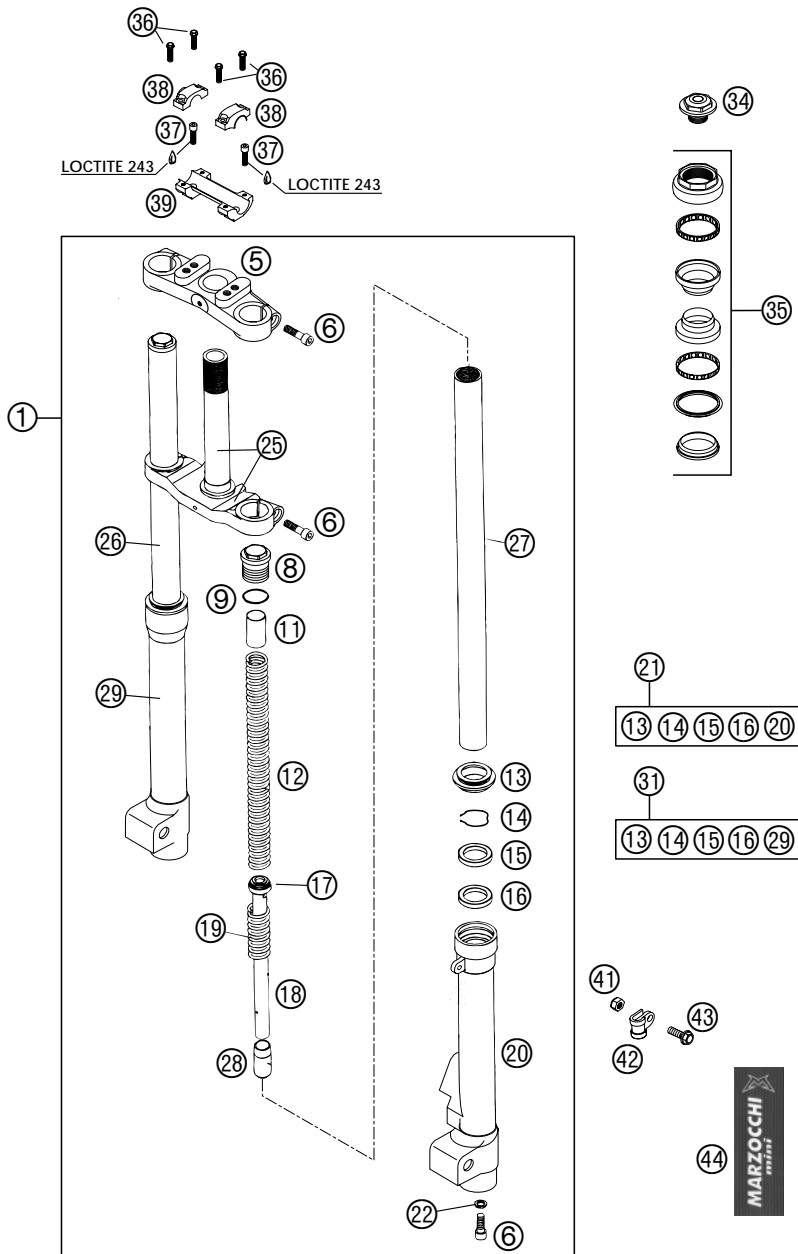

FIG	TEILNR/PARTNR	BEZEICHNUNG	DESCRIPTION	QTY
1	451.01.000.044	GABEL KPL. 50 ADV. MARZ. 2002	FORK CPL. 50 ADV. MARZ. 2002	1
5	7501476A	GABELBRÜCKE OBEN	TOP FORK PLATE	1
6	0912 080303	ISK.SCHRAUBE DIN0912-M 8X30	AH SCREW DIN0912-M 8X30	6
8	7504212AC	VERSCHLUSSKAPPE	SCREW CAP	2
9	7528010	O-RING	O-RING	2
11	7518031	VORSPANNBÜCHSE L=55MM 2002	PRE LOAD BUSH L=55MM 2002	2
12	75141169	DRUCKFEDER	SPRING	2
13	7533297	STAUBMANSCHETTE	DUST SEAL	2
14	7523264	SICHERUNGSRING	STOP RING	2
15	7528230	SIMMERRING 32/42/6,5-9,5	OIL SEAL 32/42/6,5-9,5	2
16	7522166AA	SCHEIBE D42X32,5X1,5	WASHER D42X32,5X1,5	2
17	7524157	KOLBENRING D32 NUR BEI ZUGSTUFE	PISTON RING D32 ONLY FOR REBOUND DAMPING	1
18	78031105	KOLBENSTANGE ZUGSTUFE MINI 02 ZUGSTUFE - LINKE SEITE	PISTON ROD REBOUND MINI 02 REBOUND DAMPING - LEFT SIDE	1
18	78031104	KOLBENSTANGE DRUCKSTU. MINI 02 DRUCKSTUFE - RECHTE SEITE	PISTON ROD COMPRESSION MINI 02 COMPRESSION DAMP. - RIGHT SIDE	1
19	75141015	FEDER RÜCKANSCHLAG	REBOUND SPRING	2
20	75031538A/A	GLEITROHR LINKS 2002	SLIDER LEFT SIDE 2002	1
21	75031538A/A/R	GLEITROHR LINKS KPL. 2002	SLIDER LEFT SIDE CPL. 2002	1
22	7522225	SCHEIBE 14X8X1,5	WASHER 14X8X1,5	2
25	77051124	GABELBRÜCKE UNT. KPL. MINI/JUN	BOT. FORK PLATE CPL. MINI/JUN	1
26	7708247/R	GABELHOLM RECHTS MINI/JUN. 02	FORK TUBE R/S MINI/JUN. 02	1
27	7708248/R	GABELHOLM LINKS MINI/JUN. 02	FORK TUBE L/S MINI/JUN. 02	1
28	7512068	DÄMPFUNGSROLLE	FOOT BUFFER	2
29	75031366A/A	GLEITROHR RECHTS	SLIDER RIGHT SIDE	1
31	75031366A/K/R	GLEITROHR KPL. RECHTS	SLIDER CPL. RIGHT SIDE	1
34	503.01.036.000	STEUERKOPFSCHR. M20X1,5 SW=27	STEER.HEAD SCREW M20X1,5 WS=27	1
35	451.01.081.000	STEUERSATZ KPL. 50 SXR 2001	STEER.STEM B. CPL. 50 SXR 2001	1
36	0015 080303	SK.BUNDSCHRAUBE M8X30 SW=10	HH COLLAR SCREW M8X30 WS=10	4
37	0912 100250	ISK.SCHR.DIN6912-M10X25 SICH.	AH SCREW DIN0912-M10X25 W.LOCK	2
38	503.01.038.000	LENKERKLEMMBRÜCKE D=22MM 2001	HANDLEBAR CLAMP D=22MM 2001	2
39	451.01.039.000	LENKERAUFNAHME D=22MM 2001	HANDLEBAR SUPPORT D=22MM 2001	1
41	0985 050003	SS.MUTTER DIN0985-M 5	SELF LOCKING NUT DIN0985-M 5	1
42	450.01.070.000	BREMSESEILFÜHRUNG	BRAKE CABLE GUIDE	1
43	0015 050163	SK.BUNDSCHRAUBE M 5X16 SW=8	HH COLLAR SCREW M 5X16 WS=8	1
44	7547325	AUFKLEBER LINKS MARZOCCHI	STICKER LEFT SIDE MARZOCCHI	1
—	7547331	AUFKLEBER RECHTS MARZOCCHI	STICKER RIGHT SIDE MARZOCCHI	1

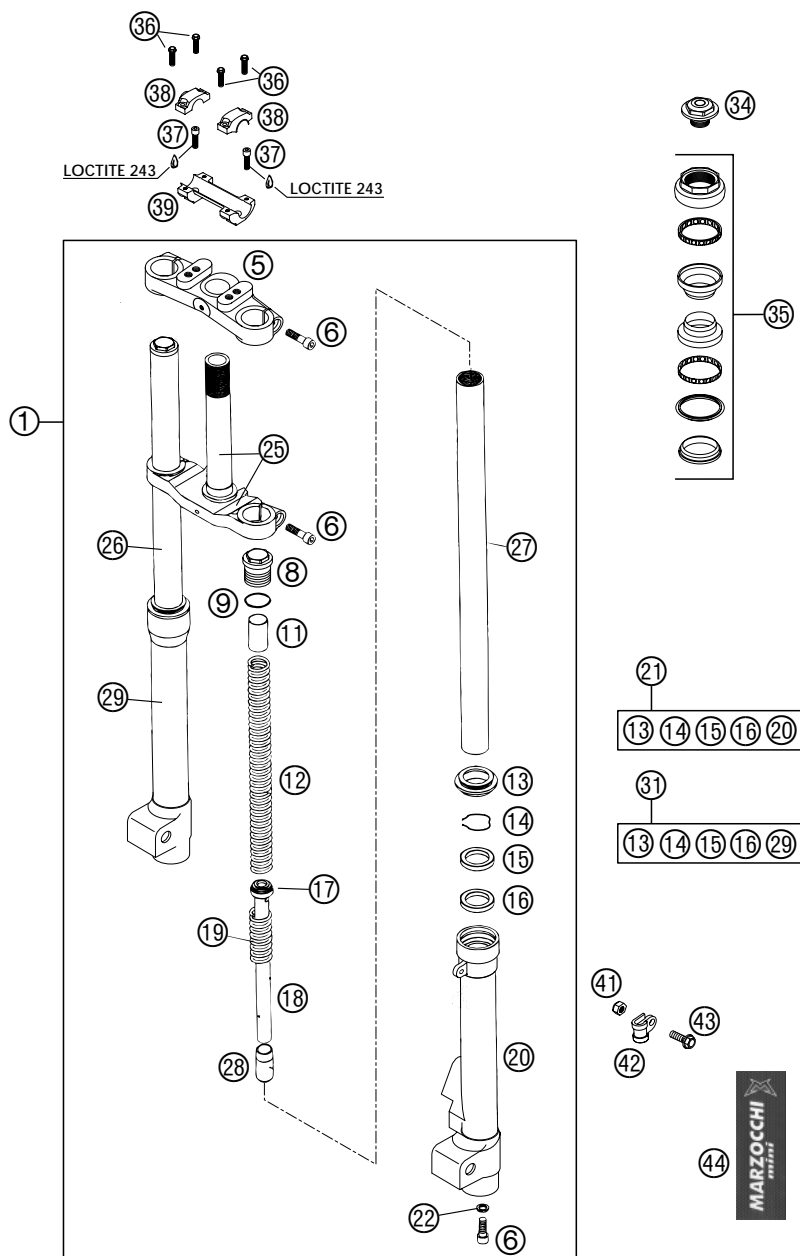

FIG	TEILNR/PARTNR	BEZEICHNUNG	DESCRIPTION	QTY
1	451.01.000.244	GABEL KPL. JUN.ADV. MARZ. 2002	FORK CPL. JUN. ADV. MARZ. 2002	1
5	7501476A	GABELBRÜCKE OBEN	TOP FORK PLATE	1
6	0912 080303	ISK.SCHRAUBE DIN0912-M 8X30	AH SCREW DIN0912-M 8X30	6
8	7504212AC	VERSCHLUSSKAPPE	SCREW CAP	2
9	7528010	O-RING	O-RING	2
11	7518031	VORSPANNBÜCHSE L=55MM 2002	PRE LOAD BUSH L=55MM 2002	2
12	75141169	DRUCKFEDER	SPRING	2
13	7533297	STAUBMANSCHETTE	DUST SEAL	2
14	7523264	SICHERUNGSRING	STOP RING	2
15	7528230	SIMMERRING 32/42/6,5-9,5	OIL SEAL 32/42/6,5-9,5	2
16	7522166AA	SCHEIBE D42X32,5X1,5	WASHER D42X32,5X1,5	2
17	7524157	KOLBENRING D32 NUR BEI ZUGSTUFE	PISTON RING D32 ONLY FOR REBOUND DAMPING	1
18	7803936/A	KOLBENSTANGE ZUGSTUFE JUN. 02 ZUGSTUFE - LINKE SEITE	PISTON ROD REBOUND JUNIOR 02 REBOUND DAMPING - LEFT SIDE	1
18	7803938/A	KOLBENSTANGE DRUCKSTUFE JUN.02 DRUCKSTUFE - RECHTE SEITE	PISTON ROD COMPRESSION JUN. 02 COMPRESSION DAMP. - RIGHT SIDE	1
19	75141015	FEDER RÜCKANSCHLAG	REBOUND SPRING	2
20	75031538A/A	GLEITROHR LINKS 2002	SLIDER LEFT SIDE 2002	1
21	75031538A/A/R	GLEITROHR LINKS KPL. 2002	SLIDER LEFT SIDE CPL. 2002	1
22	7522225	SCHEIBE 14X8X1,5	WASHER 14X8X1,5	2
25	77051124	GABELBRÜCKE UNT. KPL. MINI/JUN	BOT. FORK PLATE CPL. MINI/JUN	1
26	7708247/R	GABELHOLM RECHTS MINI/JUN. 02	FORK TUBE R/S MINI/JUN. 02	1
27	7708248/R	GABELHOLM LINKS MINI/JUN. 02	FORK TUBE L/S MINI/JUN. 02	1
28	7512068	DÄMPFUNGSROLLE	FOOT BUFFER	2
29	75031366A/A	GLEITROHR RECHTS	SLIDER RIGHT SIDE	1
31	75031366A/K/R	GLEITROHR KPL. RECHTS	SLIDER CPL. RIGHT SIDE	1
34	503.01.036.000	STEUERKOPFSCHR. M20X1,5 SW=27	STEER.HEAD SCREW M20X1,5 WS=27	1
35	451.01.081.000	STEUERSATZ KPL. 50 SXR 2001	STEER.STEM B. CPL. 50 SXR 2001	1
36	0015 080303	SK.BUNDSCHRAUBE M8X30 SW=10	HH COLLAR SCREW M8X30 WS=10	4
37	0912 100250	ISK.SCHR.DIN6912-M10X25 SICH.	AH SCREW DIN0912-M10X25 W.LOCK	2
38	503.01.038.000	LENKERKLEMMBRÜCKE D=22MM 2001	HANDLEBAR CLAMP D=22MM 2001	2
39	451.01.039.000	LENKERAUFNAHME D=22MM 2001	HANDLEBAR SUPPORT D=22MM 2001	1
41	0985 050003	SS.MUTTER DIN0985-M 5	SELF LOCKING NUT DIN0985-M 5	1
42	450.01.070.000	BREMSESELFÜHRUNG	BRAKE CABLE GUIDE	1
43	0015 050163	SK.BUNDSCHRAUBE M 5X16 SW=8	HH COLLAR SCREW M 5X16 WS=8	1
44	7547325	AUFKLEBER LINKS MARZOCCHI	STICKER LEFT SIDE MARZOCCHI	1
—	7547331	AUFKLEBER RECHTS MARZOCCHI	STICKER RIGHT SIDE MARZOCCHI	1

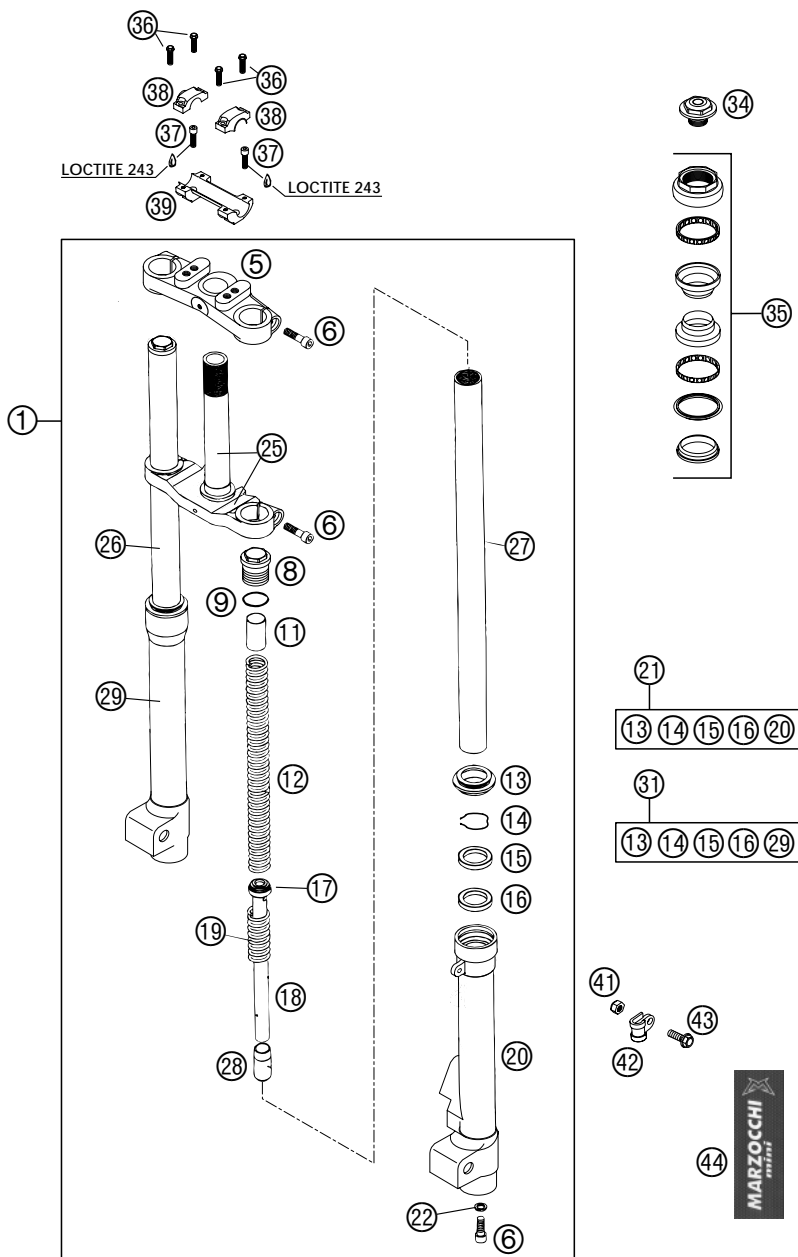

FIG	TEILNR/PARTNR	BEZEICHNUNG	DESCRIPTION	QTY
1	451.01.000.344	GABEL KPL. SEN.ADV. MARZ. 2002	FORK CPL. SEN. ADV. MARZ. 2002	1
5	7501476A	GABELBRÜCKE OBEN	TOP FORK PLATE	1
6	0912 080303	ISK.SCHRAUBE DIN0912-M 8X30	AH SCREW DIN0912-M 8X30	6
8	7504212AC	VERSCHLUSSKAPPE	SCREW CAP	2
9	7528010	O-RING	O-RING	2
11	7518076	VORSPANNBÜCHSE 25X2,5X100	PRE LOAD BUSH 25X2,5X100	2
12	75141169	DRUCKFEDER	SPRING	2
13	7533297	STAUBMANSCHETTE	DUST SEAL	2
14	7523264	SICHERUNGSRING	STOP RING	2
15	7528230	SIMMERRING 32/42/6,5-9,5	OIL SEAL 32/42/6,5-9,5	2
16	7522166AA	SCHEIBE D42X32,5X1,5	WASHER D42X32,5X1,5	2
17	7524157	KOLBENRING D32 NUR BEI ZUGSTUFE	PISTON RING D32 ONLY FOR REBOUND DAMPING	1
18	78031047	KOLBENSTANGE ZUGSTUFE SEN. 01 ZUGSTUFE - LINKE SEITE	PISTON ROD REBOUND SEN. 01 REBOUND DAMPING - LEFT SIDE	1
18	78031045	KOLBENSTANGE DRUCKSTUFE SEN.01 DRUCKSTUFE - RECHTE SEITE	PISTON ROD COMPRESSION SEN. 01 COMPRESSION DAMP. - RIGHT SIDE	1
19	75141015	FEDER RÜCKANSCHLAG	REBOUND SPRING	2
20	75031538A/A	GLEITROHR LINKS 2002	SLIDER LEFT SIDE 2002	1
21	75031538A/A/R	GLEITROHR LINKS KPL. 2002	SLIDER LEFT SIDE CPL. 2002	1
22	7522225	SCHEIBE 14X8X1,5	WASHER 14X8X1,5	2
25	77051095	GABELBRÜCKE UNTEN KPL. SEN. 01	BOT. FORK PLATE CPL. SEN. 01	1
26	7708249/R	GABELHOLM RECHTS SENIOR 02	FORK TUBE R/S SENIOR 02	1
27	7708250/R	GABELHOLM LINKS SENIOR 02	FORK TUBE L/S SENIOR 02	1
28	7512068	DÄMPFUNGSROLLE	FOOT BUFFER	2
29	75031366A/A	GLEITROHR RECHTS	SLIDER RIGHT SIDE	1
31	75031366A/K/R	GLEITROHR KPL. RECHTS	SLIDER CPL. RIGHT SIDE	1
34	503.01.036.000	STEUERKOPFSCHR. M20X1,5 SW=27	STEER.HEAD SCREW M20X1,5 WS=27	1
35	451.01.081.000	STEUERSATZ KPL. 50 SXR 2001	STEER.STEM B. CPL. 50 SXR 2001	1
36	0015 080303	SK.BUNDSCHRAUBE M8X30 SW=10	HH COLLAR SCREW M8X30 WS=10	4
37	0912 100250	ISK.SCHR.DIN6912-M10X25 SICH.	AH SCREW DIN0912-M10X25 W.LOCK	2
38	503.01.038.000	LENKERKLEMMBRÜCKE D=22MM 2001	HANDLEBAR CLAMP D=22MM 2001	2
39	451.01.039.000	LENKERAUFNAHME D=22MM 2001	HANDLEBAR SUPPORT D=22MM 2001	1
41	0985 050003	SS.MUTTER DIN0985-M 5	SELF LOCKING NUT DIN0985-M 5	1
42	450.01.070.000	BREMSESELFÜHRUNG	BRAKE CABLE GUIDE	1
43	0015 050163	SK.BUNDSCHRAUBE M 5X16 SW=8	HH COLLAR SCREW M 5X16 WS=8	1
44	7547325	AUFKLEBER LINKS MARZOCCHI	STICKER LEFT SIDE MARZOCCHI	1
—	7547331	AUFKLEBER RECHTS MARZOCCHI	STICKER RIGHT SIDE MARZOCCHI	1

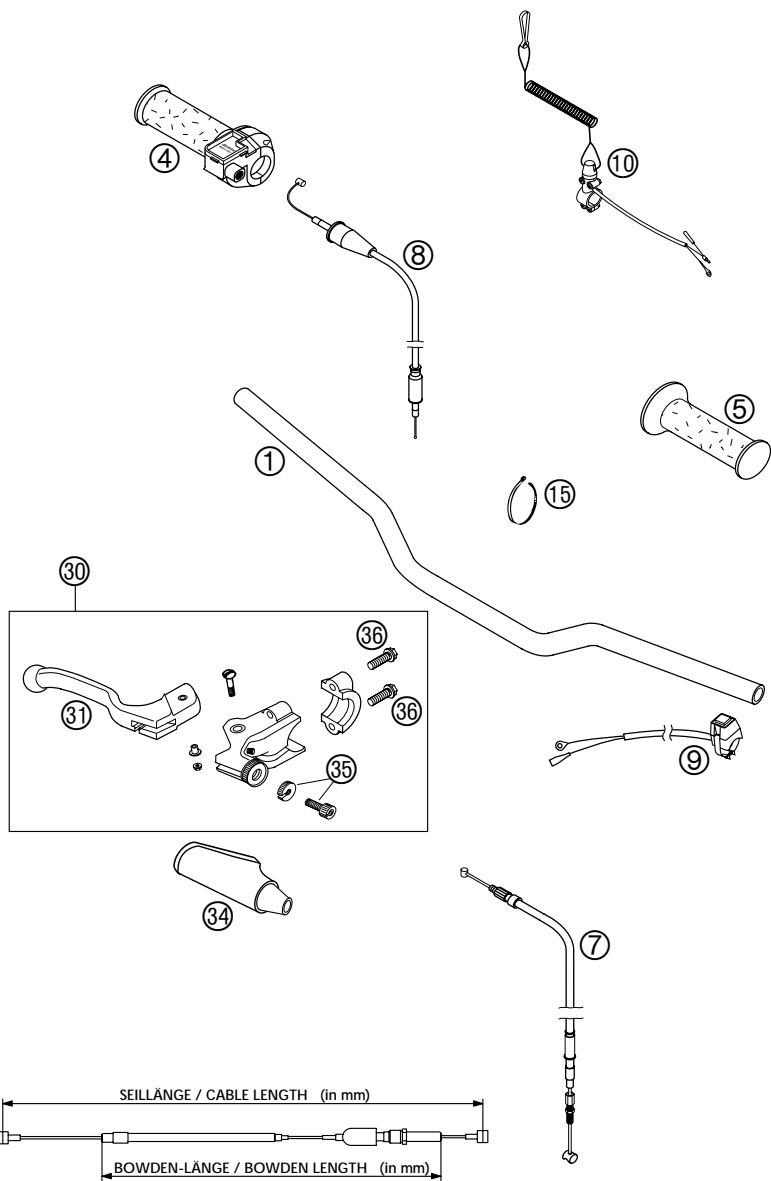

FIG	TEILNR/PARTNR	BEZEICHNUNG	DESCRIPTION	QTY
1	450.02.001.000	LENKER 50 SXR	HANDLEBAR 50 SXR	1
4	450.02.010.000	GASDREHGRIF KPL. 50 SXR	TWIST GRIP CPL. 50 SXR	1
5	450.02.039.000	FESTGRIF	RUBBER GRIP	1
7	451.13.010.000	BREMSEIL VORNE 898/772 01	BRAKE CABLE FRONT 898/772 01	1
		MINI ADV.	MINI ADV.	
7	451.13.010.100	BREMSEIL VORNE 990/864 01	BRAKE CABLE FRONT 990/864 01	1
		JUNIOR ADV., SENIOR ADV.	JUNIOR ADV., SENIOR ADV.	
-	451.13.070.000	BREMSEIL HINTEN 1187/1052 01	BRAKE CABLE REAR 1187/1052 01	1
		MINI ADV., JUNIOR ADV.	MINI ADV., JUNIOR ADV.	
-	451.13.070.100	BREMSEIL HINTEN 1287/1152 01	BRAKE CABLE REAR 1287/1152 01	1
		SENIOR ADV.	SENIOR ADV.	
8	451.02.091.100	GASSEIL JUNIOR 762/644 2002	THROTTLE CABLE JUN.726/644 02	1
		MINI ADV., JUNIOR ADV.	MINI ADV., JUNIOR ADV.	
8	451.02.091.000	GASSEIL SENIOR 849/726 2001	THROTTLE CABLE SEN.849/726 01	1
		SENIOR ADV.	SENIOR ADV.	
9	503.11.089.200	KURZSCHLUSSSCHALTER 02	SHORT CISCUIT BUTTON 02	1
10	450.11.089.044	KURZSCHL.SCHALTER M.REISSLEINE	S.CIRCUIT BUTTON W. RIP CORD	X
15	440.11.076.200	KABELBAND 200MM	CABLE TIE 200MM	X
15	440.11.076.100	KABELBAND 100MM	CABLE TIE 100MM	X
30	451.13.001.044	HANDBREMSHEBEL KPL. RE. 2001	HAND BRAKE LEVER CPL. R/S 2001	1
-	460.02.040.100	KUPPLUNGSH. KPL. 60/65 SX '99	CLUTCH LEVER CPL. 60/65 SX '99	1
31	451.13.042.000	HANDBREMSHEBEL LOSE 65 SX 2001	HAND BRAKE LEVER L. 65 SX 2001	1
-	460.02.042.100	KUPPLUNGSH. LOSE 60/65 SX '99	CLUTCH LEVER LOOSE 60/65SX '99	1
34	460.02.048.000	SCHUTZKAPPE FÜR KUPPLUNGSH. 2000	PLASTIC CAP FOR CLUTCH LEVER	2
35	460.02.043.100	STELLSCHRAUBE KUPPLUNGSH. 2000	ADJUST SCREW CLUTCH LEVER 2000	2
36	0015 060203	SK.BUNDSCHRAUBE M 6X20 SW=8	HH COLLAR SCREW M 6X20 WS=8	4

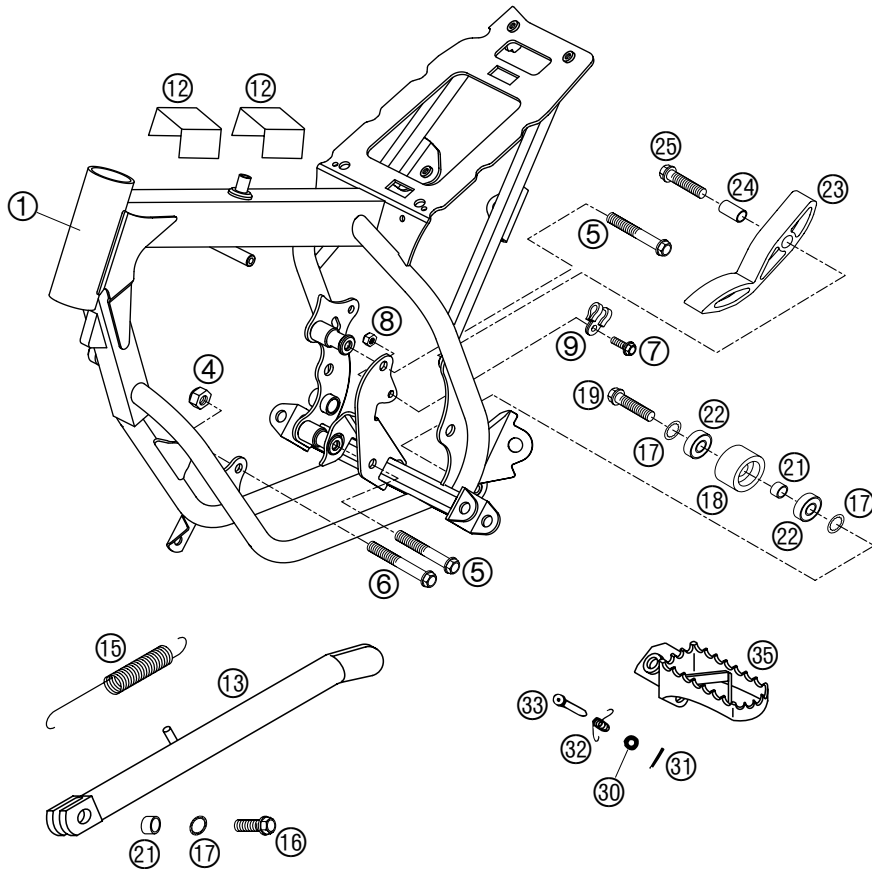

FIG	TEILNR/PARTNR	BEZEICHNUNG	DESCRIPTION	QTY
1	451.03.001.200	RAHMEN MINI ADV./JUN. ADV. 02	FRAME MIN ADV./JUN. ADV. 2002	1
4	543.10.086.200	STOVER-FLANSCHMUTTER M8 10.9	SELF LOCKING NUT M8 10.9	1
5	0015 080603	SK.BUNDSCHRAUBE M 8X60 SW=10	HH COLLAR SCREW M 8X60 WS=10	2
6	0015 080653	SK.BUNDSCHRAUBE M 8X65 SW=10	HH COLLAR SCREW M8X65 SW10	1
7	0015 050163	SK.BUNDSCHRAUBE M 5X16 SW=8	HH COLLAR SCREW M 5X16 WS=8	1
8	0985 050003	SS.MUTTER DIN0985-M 5	SELF LOCKING NUT DIN0985-M 5	1
9	450.01.070.000	BREMSESEILFÜHRUNG	BRAKE CABLE GUIDE	1
12	587.11.054.050	METAMOLL F. BATTERIEHALTEBÜGEL	METAMOLL FOR BATTERY BRACKET	2
13	451.03.023.100/90	SEITENSTÄND.L=270MM SILBER 02 MINI ADV.	SIDE STAND L=270MM SILVER 02 MINI ADV.	1
13	451.03.023.200/90	SEITENSTÄND.L=285MM SILBER 02 JUNIOR ADV.	SIDE STAND L=285MM SILVER 02 JUNIOR ADV.	1
15	510.03.021.000	STÄNDERFEDER LANG	SIDESTAND SPRING LONG	1
16	0015 080203	SK.BUNDSCHRAUBE M 8X20 SW=10	HH COLLAR SCREW M 8X20 WS=10	1
17	360.03.014.000	SCHNORR-SICHERUNGSSCHEIBE 8MM	LOCK WASHER 8MM	3
18	502.03.053.000	KETTENROLLE D=30MM	CHAIN ROLL D=30MM	1
19	0015 080303	SK.BUNDSCHRAUBE M 8X30 SW=10	HH COLLAR SCREW M 8X30 WS=10	1
21	740.03.021.000	BÜCHSE 8 X 12 X 6,5	BUSHING 8 X 12 X 6,5	2
22	0625 006087	RILLENKUGELLAGER 608 2RS C3	GROOVED BALL BEAR. 608 2RS C3	2
23	511.03.053.000	KETTENGLEITSTÜCK UNTEN '97	CHAIN SLIDING PIECE BELOW '97	1
24	511.03.053.051	BÜCHSE 8,2X10X20	BUSHING 8,2X10X20	1
25	0015 080253	SK.BUNDSCHRAUBE M 8X25 SW=10	HH COLLAR SCREW M 8X25 WS=10	1
30	0125 080003	UNTERLEGSCHLEIBE DIN0125-A 8,4	WASHER DIN0125-A 8,4	2
31	0094 032253	SPLINT DIN0094-3,2X25 STAHL	PIN DIN0094-3,2X25 STEEL	2
32	546.03.041.000	FUSSRASTENFEDER LINKS & RECHTS	FOOTREST SPRING L/S & R/S	2
33	546.03.044.000	BOLZEN FÜR FUSSRASTER 9,8 X 50	BOLT FOR FOOTREST 9,8 X 50	2
35	546.03.040.000/90	FUSSRASTE LINKS SILBER	FOOT REST L/S SILVER	1
—	546.03.140.000/90	FUSSRASTE RECHTS SILBER '98	FOOT REST R/S SILVER '98	1

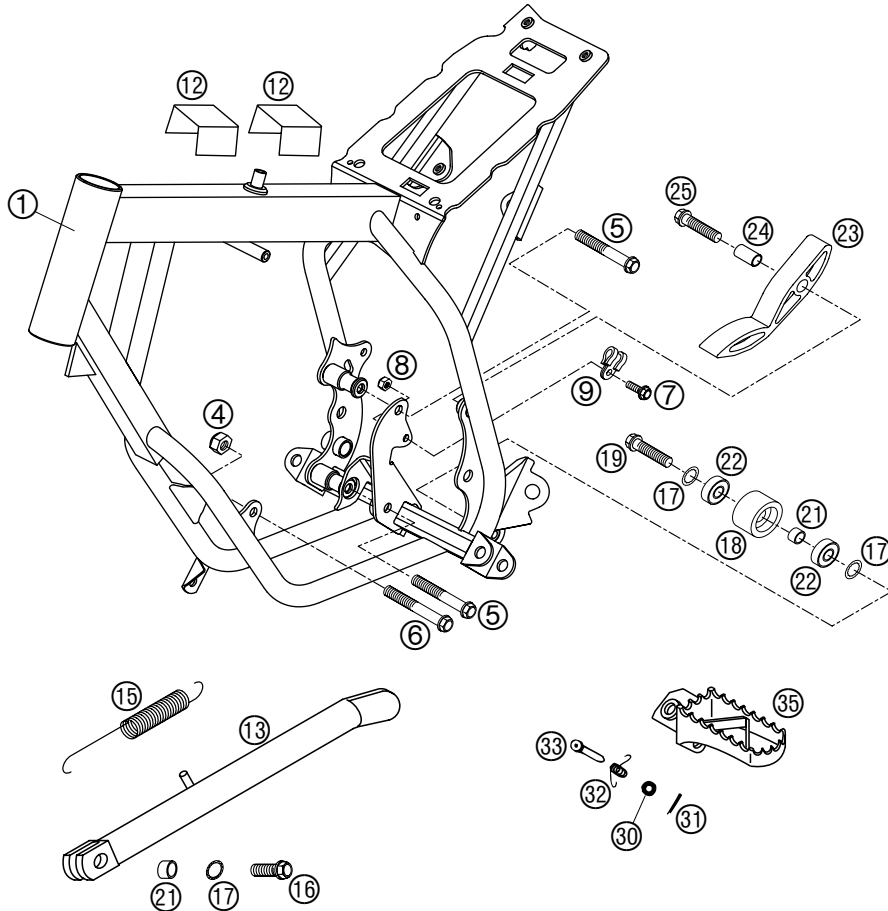

FIG	TEILNR/PARTNR	BEZEICHNUNG	DESCRIPTION	QTY
1	451.03.001.300	RAHMEN SENIOR ADV. 2002	FRAME SENIOR ADV. 2002	1
4	543.10.086.200	STOVER-FLANSCHMUTTER M8 10.9	SELF LOCKING NUT M8 10.9	1
5	0015 080603	SK.BUNDSCHRAUBE M 8X60 SW=10	HH COLLAR SCREW M 8X60 WS=10	2
6	0015 080653	SK.BUNDSCHRAUBE M 8X65 SW=10	HH COLLAR SCREW M8X65 SW10	1
7	0015 050163	SK.BUNDSCHRAUBE M 5X16 SW=8	HH COLLAR SCREW M 5X16 WS=8	1
8	0985 050003	SS.MUTTER DIN0985-M 5	SELF LOCKING NUT DIN0985-M 5	1
9	450.01.070.000	BREMSESEILFÜHRUNG	BRAKE CABLE GUIDE	1
12	587.11.054.050	METAMOLL F. BATTERIEHALTEBÜGEL	METAMOLL FOR BATTERY BRACKET	2
13	451.03.023.000/90	SEITENSTÄND.L=319MM SILBER 01	SIDE STAND L=319MM SILVER 2001	1
15	510.03.021.000	STÄNDERFEDER LANG	SIDESTAND SPRING LONG	1
16	0015 080203	SK.BUNDSCHRAUBE M 8X20 SW=10	HH COLLAR SCREW M 8X20 WS=10	1
17	360.03.014.000	SCHNORR-SICHERUNGSSCHEIBE 8MM	LOCK WASHER 8MM	3
18	502.03.053.000	KETTENROLLE D=30MM	CHAIN ROLL D=30MM	1
19	0015 080303	SK.BUNDSCHRAUBE M 8X30 SW=10	HH COLLAR SCREW M 8X30 WS=10	1
21	740.03.021.000	BÜCHSE 8 X 12 X 6,5	BUSHING 8 X 12 X 6,5	2
22	0625 006087	RILLENKUGELLAGER 608 2RS C3	GROOVED BALL BEAR. 608 2RS C3	2
23	511.03.053.000	KETTENGLEITSTÜCK UNTEN '97	CHAIN SLIDING PIECE BELOW '97	1
24	511.03.053.051	BÜCHSE 8,2X10X20	BUSHING 8,2X10X20	1
25	0015 080253	SK.BUNDSCHRAUBE M 8X25 SW=10	HH COLLAR SCREW M 8X25 WS=10	1
30	0125 080003	UNTERLEGSCHLEIBE DIN0125-A 8,4	WASHER DIN0125-A 8,4	2
31	0094 032253	SPLINT DIN0094-3,2X25 STAHL	PIN DIN0094-3,2X25 STEEL	2
32	546.03.041.000	FUSSRASTENFEDER LINKS & RECHTS	FOOTREST SPRING L/S & R/S	2
33	546.03.044.000	BOLZEN FÜR FUSSRASTER 9,8 X 50	BOLT FOR FOOTREST 9,8 X 50	2
35	546.03.040.000/90	FUSSRASTE LINKS SILBER	FOOT REST L/S SILVER	1
—	546.03.140.000/90	FUSSRASTE RECHTS SILBER '98	FOOT REST R/S SILVER '98	1

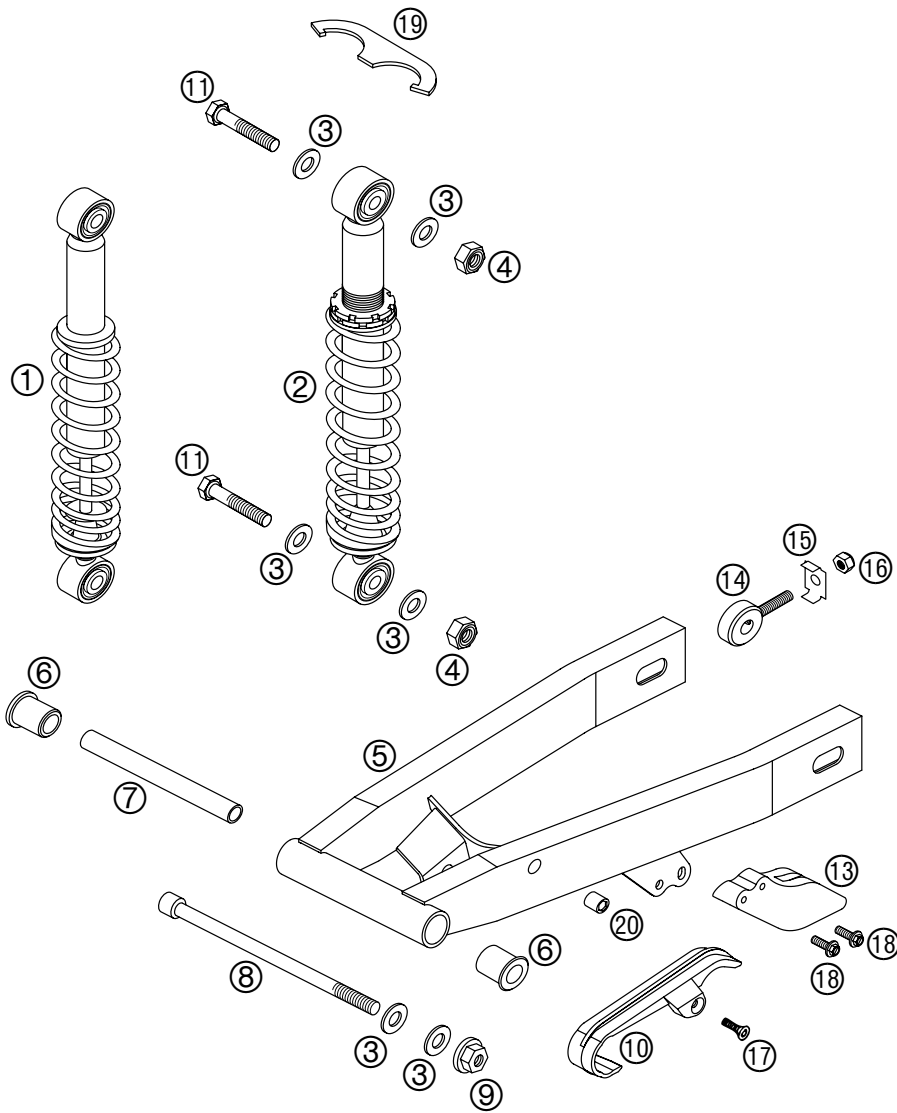

FIG	TEILNR/PARTNR	BEZEICHNUNG	DESCRIPTION	QTY
1	450.04.010.500	FEDERBEIN ADV. MC24 L=248MM*99	SHOCK ABSOR. ADV. MC24 L=248MM	1
2	451.04.010.300	FEDERBEIN SX JUN. L=255MM 02	SHOCK ABSORB. SX JUN. L=255 02	1
3	0125 100003	UNTERLEGSCHIEBE DIN0125-A10,5	WASHER DIN0125-A10,5	6
4	0985 100003	SS.MUTTER DIN0985-M10	SELF LOCKING NUT DIN0985-M10	2
5	451.04.030.000	SCHWINGARM JUNIOR ADV.+LC 2002	SWING ARM JUNIOR ADV.+LC 2002	1
6	450.04.031.000	LAGERBÜCHSE L=30 MM	BEARING BUSH L=30 MM	2
7	450.04.039.000	DISTANZROHR 10X13X140 MM	SPACING TUBE 10X13X140 MM	1
8	0912 101603	ISK.SCHRAUBE DIN0912-M10X160	AH SCREW DIN0912-M10X160	1
9	490.09.082.000	STOVERFLANSCHMUTTER M10 FK10	SELF LOCKING NUT M10 WS=17	1
10	451.04.066.000	KETTENGLEITSCH. VO. MINI 2002	CHAIN SLID. GUARD FRO. MINI 02	1
11	0931 100453	SK.SCHRAUBE DIN0931-M10X45	HH SCREW DIN0931-M10X45	2
13	451.04.070.000	KETTENFÜHRUNG MINI 2002	CHAIN GUARD MINI 2002	1
14	450.10.083.000	KETTENSPIELER	CHAIN ADJUSTER	2
15	450.10.083.060	KETTENSPIELERSTÜTZBLECH	SUPPORTING BRACKET	2
16	0985 080003	SS.MUTTER DIN0985-M 8	SELF LOCKING NUT DIN0985-M 8	2
17	0991 060203	SENKSCHRAUBE DIN7991-M 6X20	FLAT HEAD SCREW DIN7991-M 6X20	1
18	0017 060203	SONDERSCHRAUBE T60 6X20 SW=6	SPECIAL SCREW T60 6X20	2
19	450.04.010.090	HAKENSCHLÜSSEL 50 SXR	HOOK WRENCH 50 SXR	1
20	550.03.139.900	BLINDNIETMUTTER M6 STAHL 4MM	BLIND RIVET INT.THREAD M6 STE.	1

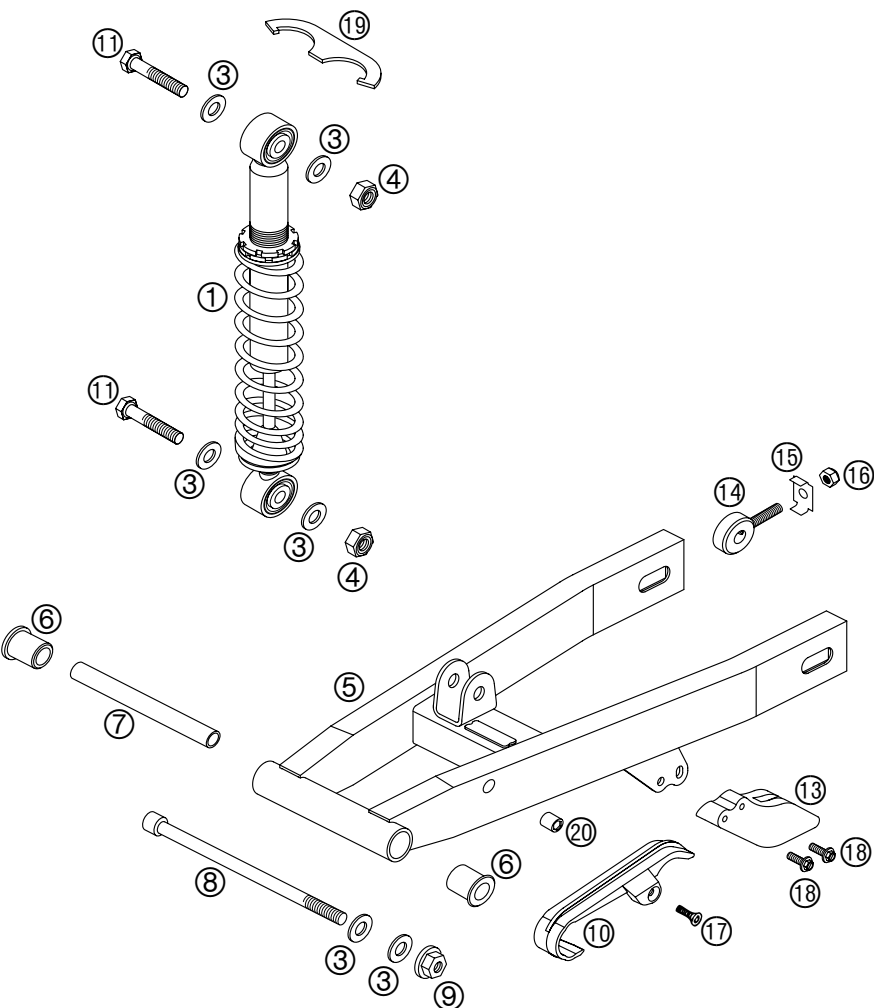

FIG	TEILNR/PARTNR	BEZEICHNUNG	DESCRIPTION	QTY
1	451.04.010.400	FEDERBEIN SX SEN. L=275MM 02	SHOCK ABSORBER SEN. L=275MM 02	1
3	0125 100003	UNTERLEGSCHIEBE DIN0125-A10,5	WASHER DIN0125-A10,5	6
4	0985 100003	SS.MUTTER DIN0985-M10	SELF LOCKING NUT DIN0985-M10	2
5	451.04.030.100	SCHWINGARM SENIOR ADV.+LC 02	SWING ARM SENIOR ADV.+LC 2002	1
6	450.04.031.000	LAGERBÜCHSE L=30 MM	BEARING BUSH L=30 MM	2
7	450.04.039.000	DISTANZROHR 10X13X140 MM	SPACING TUBE 10X13X140 MM	1
8	0912 101603	ISK.SCHRAUBE DIN0912-M10X160	AH SCREW DIN0912-M10X160	1
9	490.09.082.000	STOVERFLANSCHMUTTER M10 FK10	SELF LOCKING NUT M10 WS=17	1
10	451.04.066.000	KETTENGLEITSCH. VO. MINI 2002	CHAIN SLID. GUARD FRO. MINI 02	1
11	0931 100453	SK.SCHRAUBE DIN0931-M10X45	HH SCREW DIN0931-M10X45	2
13	451.04.070.000	KETTENFÜHRUNG MINI 2002	CHAIN GUARD MINI 2002	1
14	450.10.083.000	KETTENSANNER	CHAIN ADJUSTER	2
15	450.10.083.060	KETTENSANNERSTÜTZBLECH	SUPPORTING BRACKET	2
16	0985 080003	SS.MUTTER DIN0985-M 8	SELF LOCKING NUT DIN0985-M 8	2
17	0991 060203	SENKSCHEIBE DIN7991-M 6X20	FLAT HEAD SCREW DIN7991-M 6X20	1
18	0017 060203	SONDERSCHRAUBE T60 6X20 SW=6	SPECIAL SCREW T60 6X20	2
19	450.04.010.090	HAKENSCHLÜSSEL 50 SXR	HOOK WRENCH 50 SXR	1
20	550.03.139.900	BLINDNIETMUTTER M6 STAHL 4MM	BLIND RIVET INT.THREAD M6 STE.	1

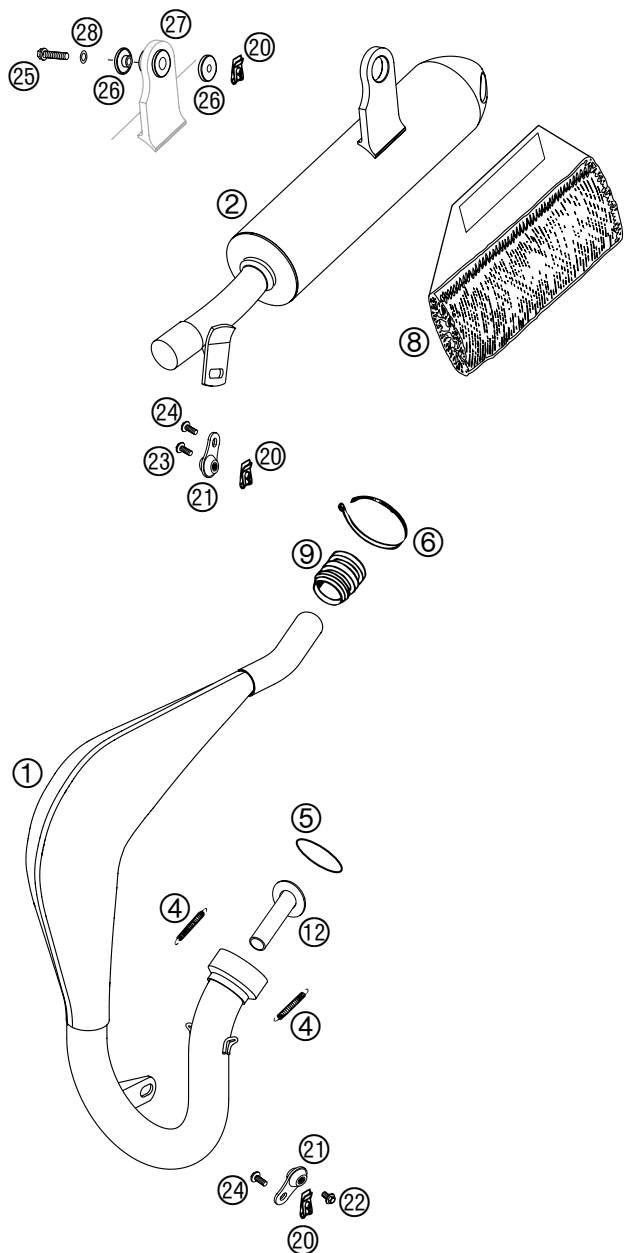

FIG	TEILNR/PARTNR	BEZEICHNUNG	DESCRIPTION	QTY
1	451.05.008.000	AUSPUFF 50 ADVENTURE 2002	EXHAUST PIPE 50 ADVENTURE 2002	1
2	451.05.079.100	ENDDÄMPFER SX JUNIOR 2002 MINI ADV., JUNIOR ADV.	SILENCER SX JUNIOR 2002 MINI ADV., JUNIOR ADV.	1
2	451.05.079.000	ENDDÄMPFER SX SENIOR 2001 SENIOR ADV.	SILENCER SX JUN/SEN 2001 SENIOR ADV.	1
4	503.05.016.000	ZUGFEDER L=55MM ÖSEN BEWEGLICH	TENSION SPRING L=55MM MOVEABLE	2
5	0770 320030	O-RING 32,00X3,00 VITON	O-RING 32,00X3,00 VITON	1
6	440.11.076.200	KABELBAND 200MM	CABLE TIE 200MM	2
8	451.05.079.056	DÄMMSTOFF FORMTEIL 50 2002 110 GRAMM GESAMTGEWICHT	ROCKWOOL PREFOMED 50 2002 110 GRAMM TOTAL WEIGHT	1
9	546.05.057.000	GUMMIMUFFE D=21/23MM '93	RUBBER SLEEVE D=21MM/23MM '93	1
12	451.05.083.000	AUSPUFFDROSSEL KPL. MINI 2002 MINI ADV.	EXHAUST THROTTLE CPL. MINI 02 MINI ADV.	1
20	546.03.048.100	MEHRBEREICHSBLECHMUTTER M6	RANGE CHANGE METAL NUT M6	3
21	503.05.012.000	SCHWINGELEMENT FÜR AUSPUFF '98	SWINGELEMENT FOR EX.PIPE '98	2
22	0014 060103	SK.BUNDSCHRAUBE M6X10 SW=8	HH COLLAR SCREW M6X10 WS=8	1
23	0015 060123	SK.BUNDSCHRAUBE M 6X12 SW=8	HH COLLAR SCREW M 6X12 WS=8	1
24	0014 060153	SK.BUNDSCHRAUBE M6X15,SW8	HH COLLAR SCREW M 6X15 WS=8	2
25	0015 060303	SK.BUNDSCHRAUBE M 6X30 SW=8	HH COLLAR SCREW M 6X30 WS=8	1
26	546.05.069.000	BÜCHSE 7,5X12X28X7,8 '96	BUSHING 7,5X12X28X7,8 '96	2
27	546.05.068.000	DÄMPFUNGELEMENT SCHWARZ	EXHAUST BRACKET RUBBER BLACK	1
28	0137 060003	FEDERSCHEIBE DIN0137-B 6	SPRING WASHER DIN0137-B 6	1

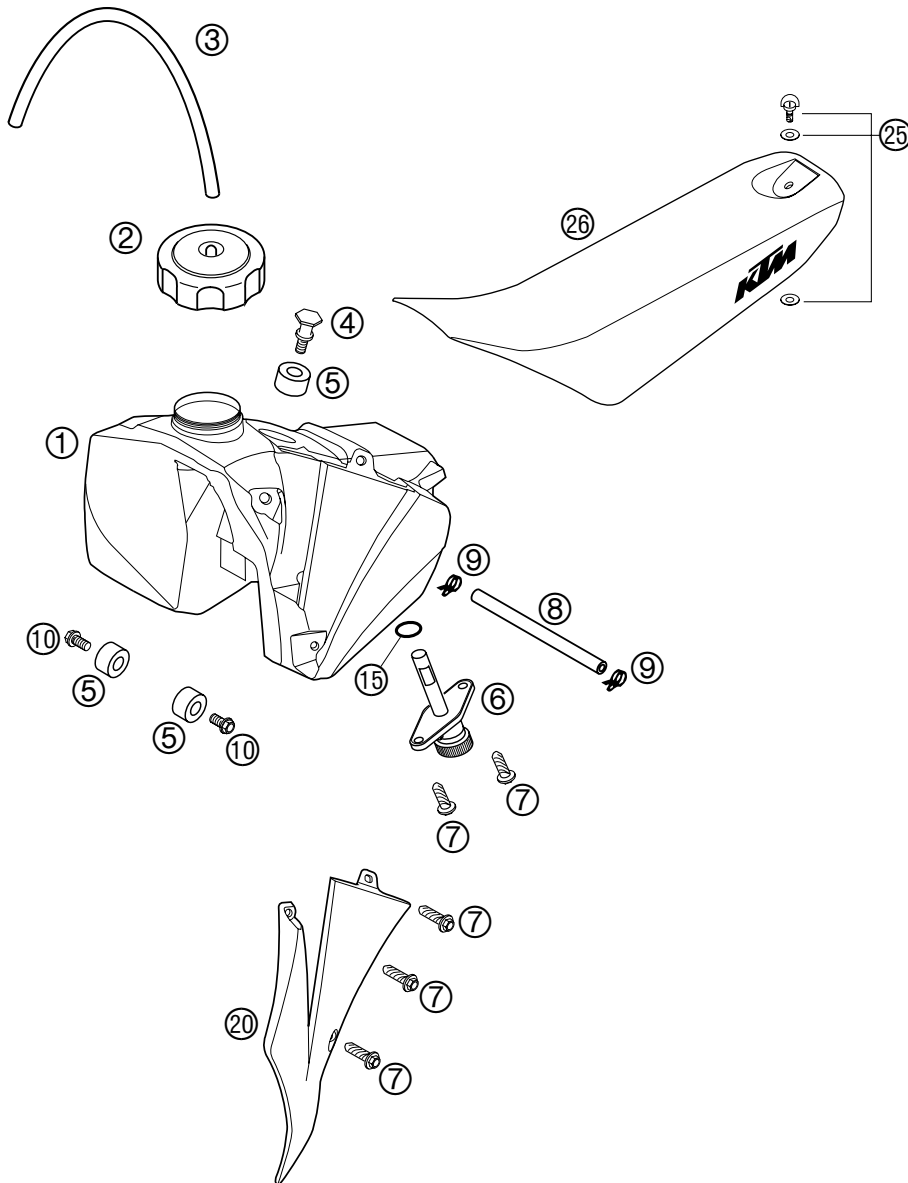

FIG	TEILNR/PARTNR	BEZEICHNUNG	DESCRIPTION	QTY
1	451.07.113.000	BENZINTANK 50 MINI AC 2002	FUEL TANK 50 MINI AC 2002	1
2	490.07.008.044	TANKVERSCHLUSS KPL. KLEIN	FILLER CAP CPL. SMALL	1
3	310.07.107.001	PVC-SCHLAUCH 6X9 MM PER METER	PVC-HOSE 6X9 MM PER METRE	0,32
4	451.07.011.000	SITZBANKBEF.SCHRAUBE 50 SX 01	TANK SCREW MINI 50 2001	1
5	503.07.014.000	TANKROLLE 12X26X12 '98	TANK ROLLER 12X26X12 '98	3
6	585.07.003.000	BENZINHAHN KPL.KLEIN RALLYE'96	FUEL COCK CPL. SMALL RALLYE'96	1
7	0017 060203	SONDERSCHRAUBE T60 6X20	SPECIAL SCREW T60 6X20	8
8	583.07.016.001	BENZINSCHL. VITON 6X1,5 PER/M	FUEL HOSE VITON 6X1,5 PER/M	0,37
9	580.07.017.000	YDNAC KLAMMER 10101 (9MM)	YDNAC CLAMP 10101 (9MM)	2
10	0015 060123	SK.BUNDSCHRAUBE M 6X12 SW=8	HH COLLAR SCREW M 6X12 WS=8	2
15	550.07.006.200	O-RING 11X1,8 NBR 70	O-RING 11X1,8 NBR 70	1
20	451.08.050.000/04	SPOILER LINKS SX JUN/SEN 2001	SPOILER LEFT SX JUN/SEN 2001	1
—	451.08.051.000/04	SPOILER RECHTS SX JUN/SEN 2001	SPOILER RIGHT SX JUN/SEN 2001	1
25	450.07.040.051	SCHNELLVERSCHLUSS KPL.50SXR'97	QUICK RELEASE CPL. 50 SXR '97	1
26	451.07.040.100	SITZBANK ADV JUN/SEN „AC“ 2002	SEAT ADV. JUN/SEN „AC“ 2002	1

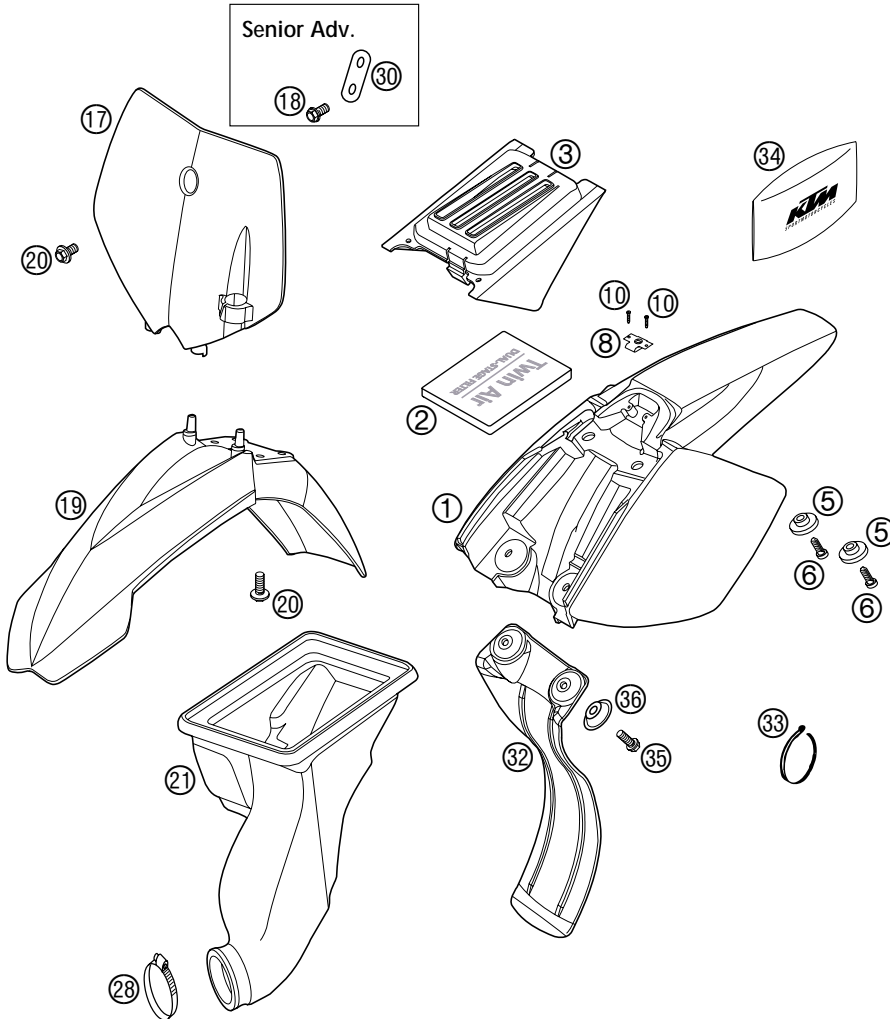
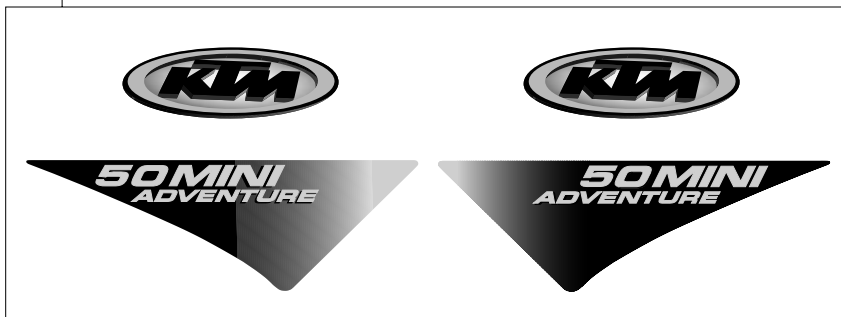

FIG	TEILNR/PARTNR	BEZEICHNUNG	DESCRIPTION	QTY
1	451.08.013.000/30	HECKTEIL 50 MINI SCHWARZ 02	REAR PART 50 MINI BLACK 02	1
2	451.06.015.000	FILTER 134 X 96 X 15 MM 2001	AIR FILTER 134X96X15 MM 2001	1
3	451.06.012.000	FILTERDECKEL JUN/SEN 2001	FILTER COVER JUN/SEN 2001	1
5	451.08.013.050	BÜCHSE F. HECK SX JUN/SEN 2001	BUSH F.REAR P. SX JUN/SEN 2001	2
6	0016 050153	PLASTITE SCHRAUBE Z 5X16	SPECIAL SCREW Z 5X16	2
8	450.07.040.050	WIDERLAGER SCHNELLVERSCHLUSS	THRUST BEARING QUICK RELEASE	1
10	0981 350163	LI.BLECHSCHR. DIN7981- 3,5X16	SHEET MET.SCR.DIN7981- 3,5X16	2
17	451.08.007.000/04	STARTNUMMERTAFEL SX JUN/SEN 01	NUMBER PLATE SX JUN/SEN 2001	1
18	0015 060123	SK.BUNDSCHRAUBE M 6X12 SW=8	HH COLLAR SCREW M 6X12 WS=8	1
19	451.08.010.000/04	KOTFLÜGEL VORNE SX JUN/SEN 01	FENDER FRONT SX JUN/SEN 2001	1
20	0014 060103	SK.BUNDSCHRAUBE M6X10 SW=8	HH COLLAR SCREW M6X10 WS=8	5
21	451.06.026.000	VERGASERMANSCHETTE SXR JUN. 02 MINI ADV., JUNIOR ADV.	CARBUR.CONNEC.BOOT SXR JUN. 02 MINI ADV., JUNIOR ADV.	1
21	451.06.026.100	VERGASERMANSCHETTE SXR SEN. 01 SENIOR ADV.	CARBUR.CONNEC.BOOT SXR SEN. 01 SENIOR ADV.	1
28	100.01.120.000	SCHLAUCHBINDER 25-40 SGT 4	CLAMP 25-40 SGT 4	1
30	451.08.007.050	HALTEBLECH F.STARTNUMMERNTAFEL	BRACKET FOR NUMBER PLATE	1
32	451.06.010.000	SPRITZSCHUTZ JUNIOR 2002 MINI ADV., JUNIOR ADV.	SPLASH PROTECTOR JUNIOR 2002 MINI ADV., JUNIOR ADV.	1
32	451.06.010.100	SPRITZSCHUTZ SENIOR 2001 SENIOR ADV.	SPLASH PROTECTOR SENIOR 2001 SENIOR ADV.	1
33	440.11.076.305	KABELBAND 290MM	CABLE TIE 290MM	2
34	450.29.099.000	BORDWERKZEUG 50 MINI, 60/65 SX	TOOL SET 50 MINI, 60/65 SX	1
35	0015 060163	SK.BUNDSCHRAUBE M 6X16 SW=8	HH COLLAR SCREW M 6X16 WS=8	2
36	722.10.079.000	STÜTZSCHALE	BUCKET	2

FIG	TEILNR/PARTNR	BEZEICHNUNG	DESCRIPTION	QTY
1	451.07.198.100	DEKORSATZ KPL. 50 MINI ADV. 02	DECAL SET CPL. 50 MINI ADV. 02	1
2	451.07.198.200	DEKORSATZ KPL. 50 JUN. ADV. 02	DECAL SET CPL. 50 JUN. ADV. 02	1
3	451.07.198.300	DEKORSATZ KPL. 50 SEN. ADV. 02	DECAL SET CPL. 50 SEN. ADV. 02	1

①



②

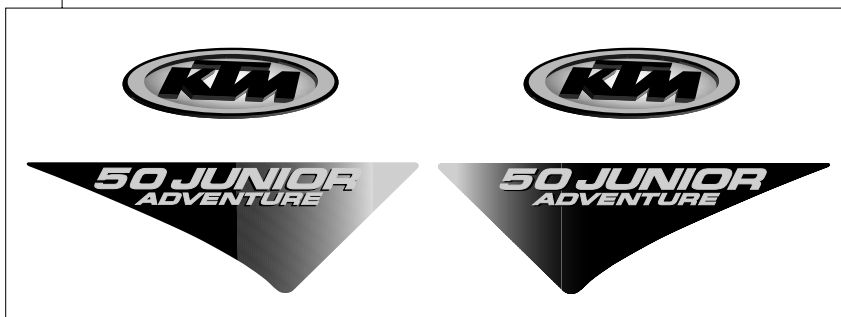

③

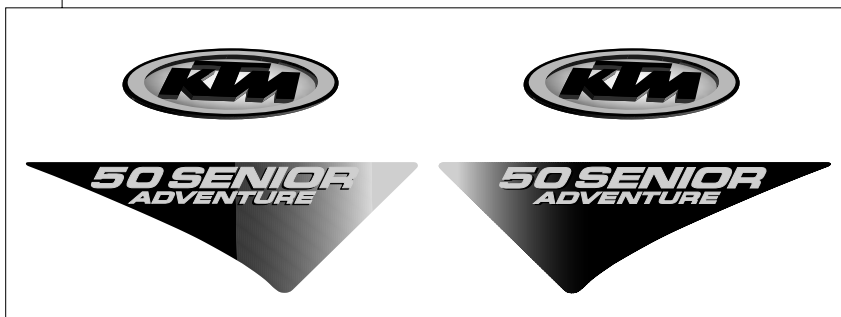

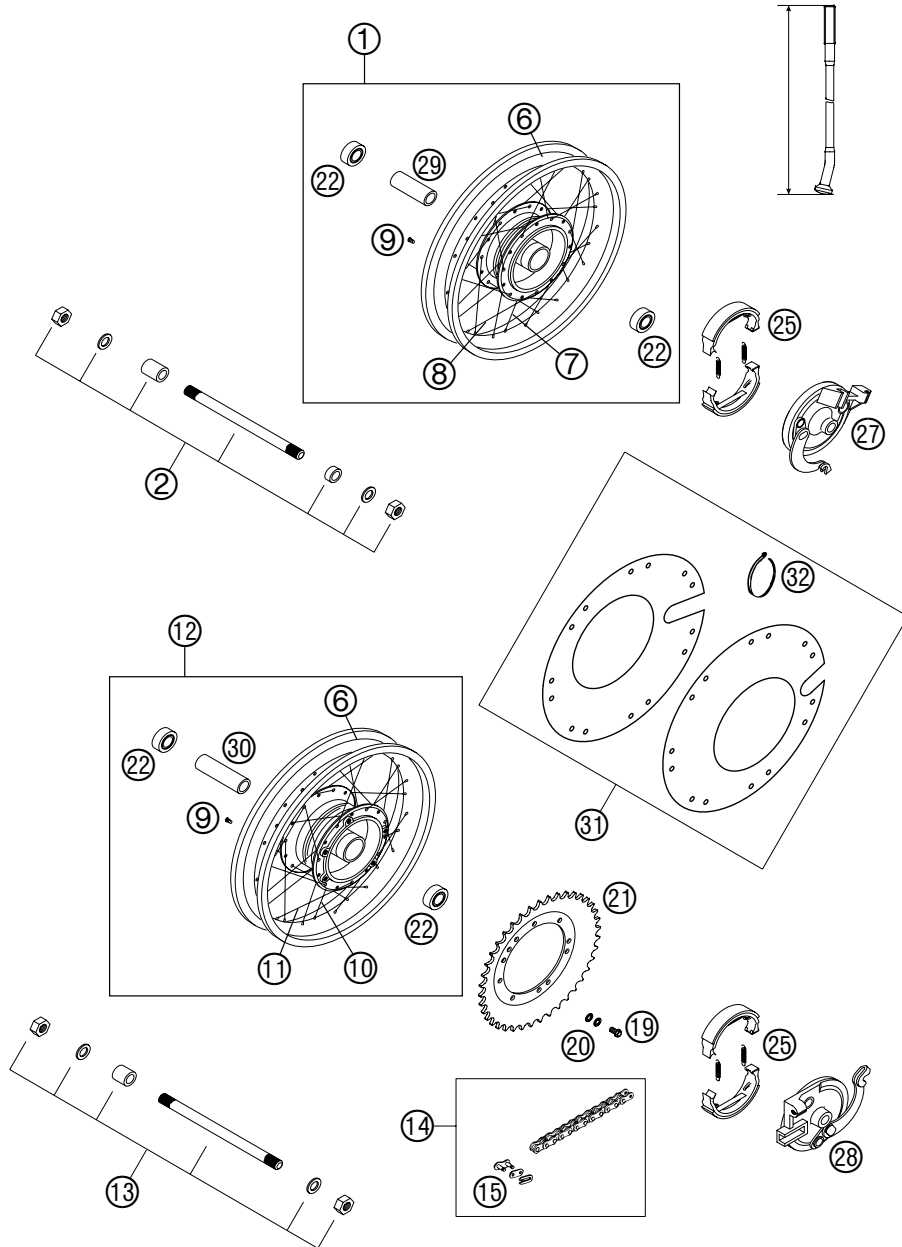
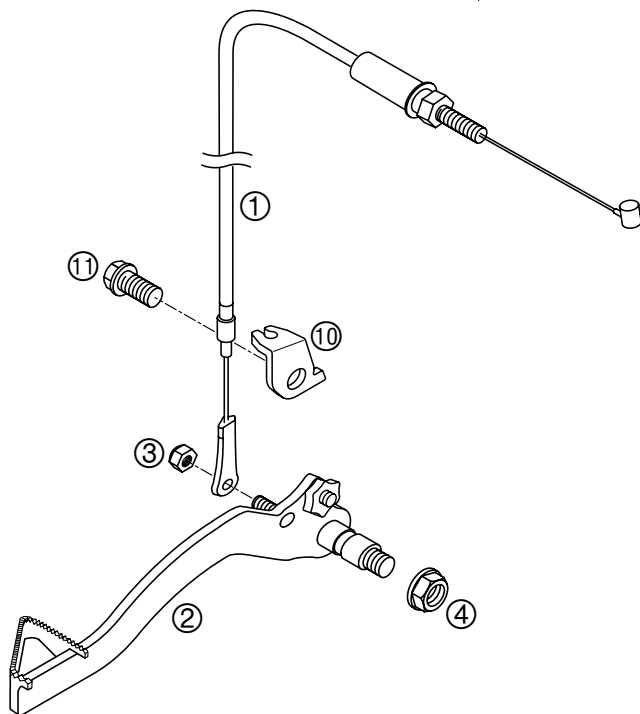
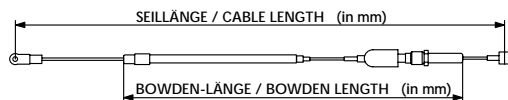

FIG	TEILNR/PARTNR	BEZEICHNUNG	DESCRIPTION	QTY
1	450.09.001.100	VORDERRAD KPL. 1,50X10" STAHL	FRONT WHEEL CPL. 1,50X10" STEEL	1
2	450.09.081.000	STECKACHSE VORNE KPL. L=202MM	AXLE FRONT CPL. L=202MM	1
6	450.09.070.000	FELGE 1,50X10" STAHL	RIM 1,50X10" STEEL	2
7	450.09.071.200	SPEICHE M3,4X70-115G 10" LI.	SPOKE M3,4X70-115G 10" L/S	14
8	450.09.171.200	SPEICHE M3,4X69-70G 10" RE.	SPOKE M3,4X69-70DG 10" R/S	14
9	451.09.072.000	SPEICHENNIPPEL M3,4 2001	SPOKE NIPPLE M3,4	56
10	450.10.071.200	SPEICHE M3,4X73-115G 10" LI.	SPOKE M3,4X73-115G 10" L/S	14
11	450.10.171.200	SPEICHE M3,4X72-70G 10" RE.	SPOKE M3,4X72-70DG 10" R/S	14
12	450.10.001.100	HINTERRAD KPL. 1,50X10" STAHL	REAR WHEEL CPL. 1,50X10" STEEL	1
13	450.10.081.000	STECKACHSE HINTEN KPL. L=214MM	AXLE REAR CPL. L=214MM	1
14	310.10.065.104	KETTE 1/2X3/16" 104 ROLLEN 104 ROLLEN	CHAIN 1/2X3/16" 104 ROLLS 104 ROLLS	1
15	310.10.066.000	KETTENSCHLOSS 1/2X3/16"	MASTER LINK 1/2X3/16"	1
19	0015 060163	SK.BUNDSCHRAUBE M 6X16 SW=8	HH COLLAR SCREW M 6X16 WS=8	5
20	502.33.041.000	NORDLOCK SCHEIBEN M 6 (PAAR)	PAIR OF WASHERS M 6 NORDLOCK	5
21	450.10.051.044	KETTENRAD 44-Z	SPROCKET 44-T	X
21	450.10.051.045	KETTENRAD 45-Z	SPROCKET 45-T	X
21	450.10.051.046	KETTENRAD 46-Z	SPROCKET 46-T	X
21	450.10.051.048	KETTENRAD 48-Z	SPROCKET 48-T	1
22	0625 060016	RILLENKUGELLAGER 6001.2RSR C3	GROOVED BALL BEARING 6001.2RSR	4
25	450.09.035.000	BREMSBACKEN-GARN.	BRAKE SHOES GARN.	2
27	450.09.030.000	TRAGPLATTE KPL. VORNE	SUPPORTING PLATE CPL. FRONT	1
28	450.10.030.000	TRAGPLATTE KPL. HINTEN	SUPPORTING PLATE CPL. REAR	1
29	450.09.011.000	DISTANZROHR VORNE	DISTANCE TUBE FRONT	1
30	450.10.011.000	DISTANZROHR HINTEN	DISTANCE TUBE REAR	1
31	450.10.092.000	RADABDECKUNG KPL. 50 SXR	WHEEL COVER CPL. 50 SXR	2
32	440.11.076.305	KABELBAND 290MM	CABLE TIE 290MM	7

FIG	TEILNR/PARTNR	BEZEICHNUNG	DESCRIPTION	QTY
1	451.13.070.200	FUSSBREMSSEIL HINTEN 810/660 SENIOR ADV.	FOOT BRAKE CABLE REAR 810/660 SENIOR ADV.	1
1	451.13.070.300	FUSSBREMSSEIL HINTEN 720/570 MINI ADV., JUN. ADV.	FOOT BRAKE CABLE REAR 720/570 MINI ADV., JUN. ADV.	1
2	451.13.050.044	FUSSBREMSHEBEL KPL. 2001	FOOT BRAKE LEVER CPL. 2001	1
3	0985 050003	SS.MUTTER DIN0985-M 5	SELF LOCKING NUT DIN0985-M 5	1
4	543.10.086.200	STOVER-FLANSCHMUTTER M8 10.9	SELF LOCKING NUT M8 10.9	1
10	451.13.052.000	BREMSWIDERLAGER MINI 2001	BRAKE THRUST BEARING MINI 2001	1
11	0015 080163	SK.BUNDSCHRAUBE M 8X16 SW=10	HH COLLAR SCREW M 8X16 WS=10	1



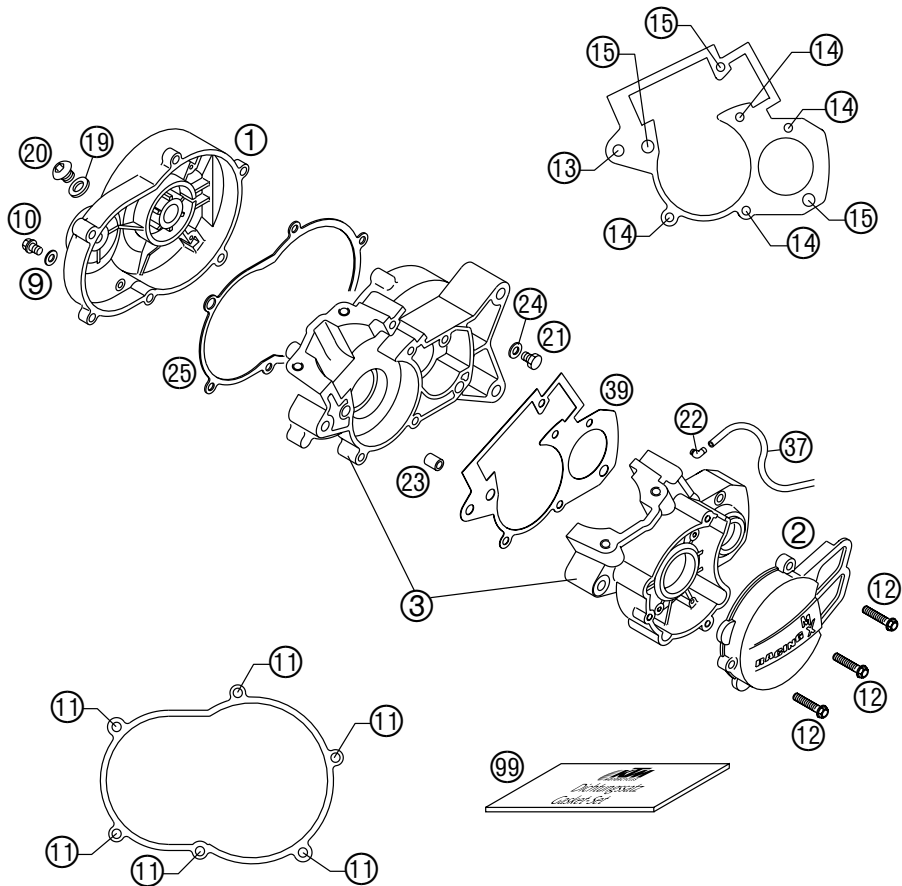
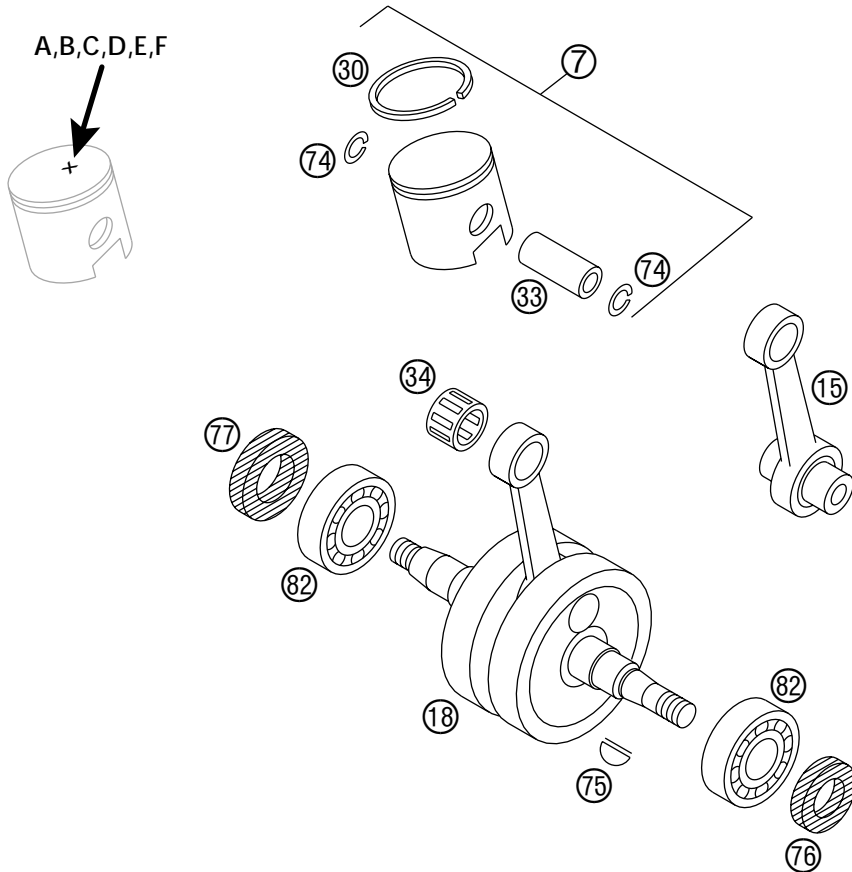

FIG	TEILNR/PARTNR	BEZEICHNUNG	DESCRIPTION	QTY
1	451.30.001.000	KUPPLUNGSDECKEL 50CCM LC 2001	CLUTCH COVER 50CCM LC 2001	1
2	451.30.502.000	ZÜNDUNGSDECKEL 50 AC 2002	IGNITION COVER 50 AC 2002	1
3	451.30.000.044	MOTERGEHÄUSE 50CCM LC 2001	ENGINE CASE 50CCM LC 2001	1
9	0603 061001	CU-DICHTRING DIN7603-6X10X1	CU-SEAL RING DIN7603-6X10X1	1
10	0015 060103	SK.BUNDSCHRAUBE M 6X10 SW=8	HH COLLAR SCREW M 6X10 WS=8	1
11	0015 060253	SK.BUNDSCHRAUBE M 6X25 SW=8	HH COLLAR SCREW M 6X25 WS=8	6
12	0015 060303	SK.BUNDSCHRAUBE M 6X30 SW=8	HH COLLAR SCREW M 6X30 WS=8	3
13	0015 080603	SK.BUNDSCHRAUBE M 8X60 SW=10	HH COLLAR SCREW M 8X60 WS=10	1
14	0912 060353	ISK.SCHRAUBE DIN0912-M 6X35	AH SCREW DIN0912-M 6X35	4
15	0912 060404	ISK.SCHRAUBE DIN0912-M 6X40	AH SCREW DIN0912-M 6X40	3
19	451.30.019.000	DICHTUNG F. ÖLEINFÜLLSCHRAUBE	GASKET FOR OIL PLUG	1
20	451.30.020.000	ÖLEINFÜLLSCHRAUBE 50 LC 2001	OIL PLUG 50 LC 2001	1
21	460.30.021.000	ÖLABLASSSCHRAUBE M10 SW=14	OIL DRAIN PLUG M10 WS=14	1
22	451.30.022.000	WINKELSTÜCK 50CCM LC 2001	ANGLE PIECE 50CCM LC 2001	1
23	451.30.023.000	PASSHÜLSE 7X9X10	DOWEL 7X9X10	4
24	0603 100141	CU-DICHTRING DIN7603-10X14X1	COPPERT GASKET 10X14X1	1
25	451.30.025.000	DICHTUNG F. KUPPL.DECKEL 2001	GASKET FOR CLUTCH COVER 2001	1
37	520.31.137.001	PVC-SCHLAUCH 3X5MM	PVC-HOSE 3X5MM	0,20
39	451.30.039.000	MOTERGEHÄUSEDICHTU. 50 LC 2001	ENGINE CASE GASKET 50 LC 2001	1
99	451.30.599.000	DICHTUNGSSATZ KPL. 50 AC 2002	GASKET SET CPL. 50 AC 2002	1

FIG	TEILNR/PARTNR	BEZEICHNUNG	DESCRIPTION	QTY
7	451.30.007.000/ A	KOLBEN KPL.39,5 „A“ 50 LC 2001	PISTON CPL.39,5 „A“ 50 LC 2001	X
7	451.30.007.000/ B	KOLBEN KPL.39,5 „B“ 50 LC 2001	PISTON CPL.39,5 „B“ 50 LC 2001	X
7	451.30.007.000/ C	KOLBEN KPL.39,5 „C“ 50 LC 2001	PISTON CPL.39,5 „C“ 50 LC 2001	X
7	451.30.007.000/ D	KOLBEN KPL.39,5 „D“ 50 LC 2001	PISTON CPL.39,5 „D“ 50 LC 2001	X
7	451.30.007.000/ E	KOLBEN KPL.39,5 „E“ 50 LC 2001	PISTON CPL.39,5 „E“ 50 LC 2001	X
7	451.30.007.000/ F	KOLBEN KPL.39,5 „F“ 50 LC 2001	PISTON CPL.39,5 „F“ 50 LC 2001	X
15	451.30.515.000	PLEUEL-REP.SATZ 50 AC 2002	CON.ROD REPAIR SET 50 AC 2002	1
18	451.30.518.000	KURBELWELLE 50 AC 2002	CRANKSHAFT 50 AC 2002	1
30	451.30.030.000	KOLBENRING 50CCM LC 2001	PISTON RING 50CCM LC 2001	1
33	451.30.033.000	KOLBENBOLZEN 50CCM LC 2001	PISTON PIN 50CCM LC 2001	1
34	451.30.034.000	NADELLAGER KOLBENBOLZ.12X15X15	NEEDLE BEARING PISTONPIN	1
74	460.30.074.000	DRAHTSPRENGRING 12X1	CIRCLIP 12X1	2
75	451.30.075.000	SCHEIBENFEDER 2,5X3,7	WOODRUFF KEY 2,5X3,7	1
76	451.30.076.000	WELLENDICHTRING 15X24X7	OIL SEAL RING 15X24X7	1
77	451.30.077.000	WELLENDICHTRING 17X35X7	OIL SEAL RING 17X35X7	1
82	451.30.082.100	KUGELLAGER 17X40X12 2002	BALL BEARING 17X40X12 2002	2

A,B,C,D,E,F



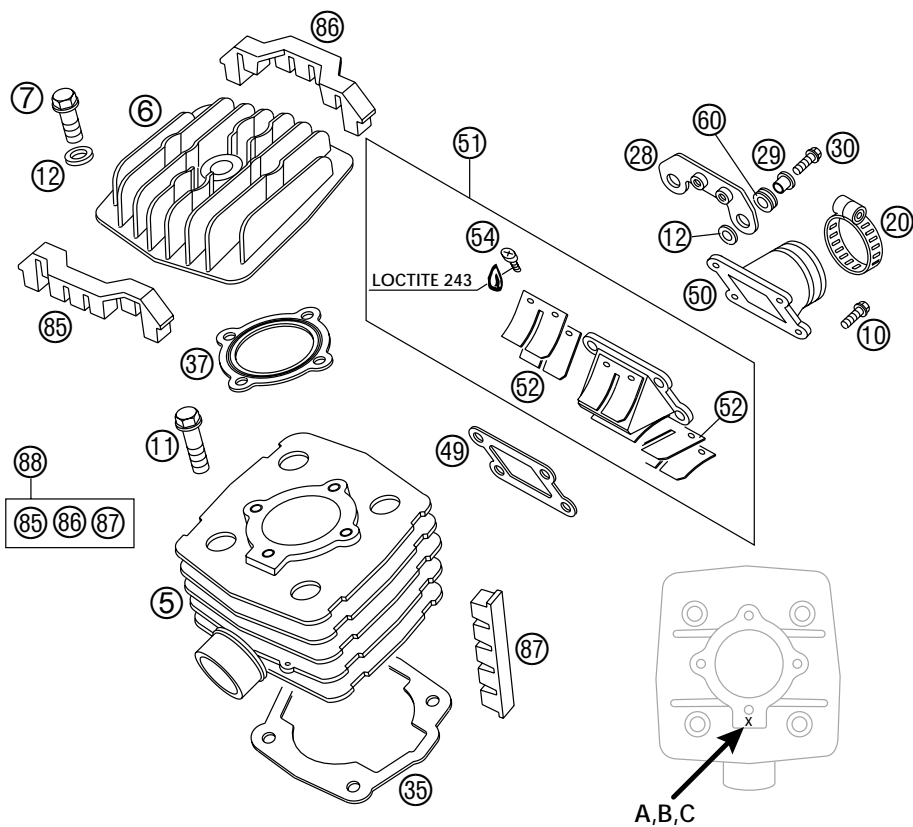

FIG	TEILNR/PARTNR	BEZEICHNUNG	DESCRIPTION	QTY
5	451.30.505.000/ A	ZYLINDER 39,5MM „A“ 50 2002	CYLINDER 39,5MM „A“ 50 2002	X
5	451.30.505.000/ B	ZYLINDER 39,5MM „B“ 50 2002	CYLINDER 39,5MM „B“ 50 2002	X
5	451.30.505.000/ C	ZYLINDER 39,5MM „C“ 50 2002	CYLINDER 39,5MM „C“ 50 2002	X
6	451.30.506.000	ZYLINDERKOPF 50 AC 2002	CYLINDER HEAD 50 AC 2002	1
7	0015 060253	SK.BUNDSCHRAUBE M 6X25 SW=8	HH COLLAR SCREW M 6X25 WS=8	4
10	0015 060203	SK.BUNDSCHRAUBE M 6X20 SW=8	HH COLLAR SCREW M 6X20 WS=8	2
11	0015 080203	SK.BUNDSCHRAUBE M 8X20 SW=10	HH COLLAR SCREW M 8X20 WS=10	4
12	0125 060003	UNTERLEGSCHIEBE DIN0125-A 6,4	WASHER DIN0125-A 6,4	6
20	100.01.120.000	SCHLAUCHBINDER 25-40 SGT 4	CLAMP 25-40 SGT 4	1
28	451.39.028.000	HALTEBLECH ZÜNDSPULE 50LC 2001	BRACKET IGNITI. COIL 50LC 2001	1
29	451.39.128.000	BUNDBÜCHSE 6,3X8X7,5	COLLAR BUSHING 6,3X8X7,5	2
30	0015 060303	SK.BUNDSCHRAUBE M 6X30 SW=8	HH COLLAR SCREW M 6X30 WS=8	2
35	460.30.035.020	ZYLINDERFUSSDICHTUNG 0,2 MM	CYLINDER BASE GASKET 0,2 MM	X
35	460.30.035.050	ZYLINDERFUSSDICHTUNG 0,5 MM	CYLINDER BASE GASKET 0,5 MM	X
37	451.30.537.000	ZYLINDERKOPFDICHTUNG 50 AC 02	CYLINDER HEAD GASKET 50 AC 02	1
49	460.30.049.000	ANSAUGFLANSCHDICHTUNG	INTAKE VALVE GASKET	1
50	451.30.050.000	ANSAUGFLANSCH 50CCM LC 2001	INLET MANIFOLD 50CCM LC 2001	1
51	451.30.051.044	MEMBRANGEHÄUSE KPL. 50 LC 2001	MEMBRANE HOUSING CPL.50LC 2001	1
52	460.30.052.000	MEMBRAN LOSE 60/65 CCM	MEMBRANE LOOSE 60/65 CCM	2
54	0985 030063	LINSENSCHRAUBE DIN7985-M 3X6	FLAT HEAD SCREW DIN7985-M 3X6	4
60	310.08.060.000	KABELTÜLLE D=8MM OFFEN	RUBBER SLEEVE D=8MM OPEN	2
88	451.30.588.000	DÄMPFERGUMMI-SET 2002	DAMPING RUBBER-SET 2002	1

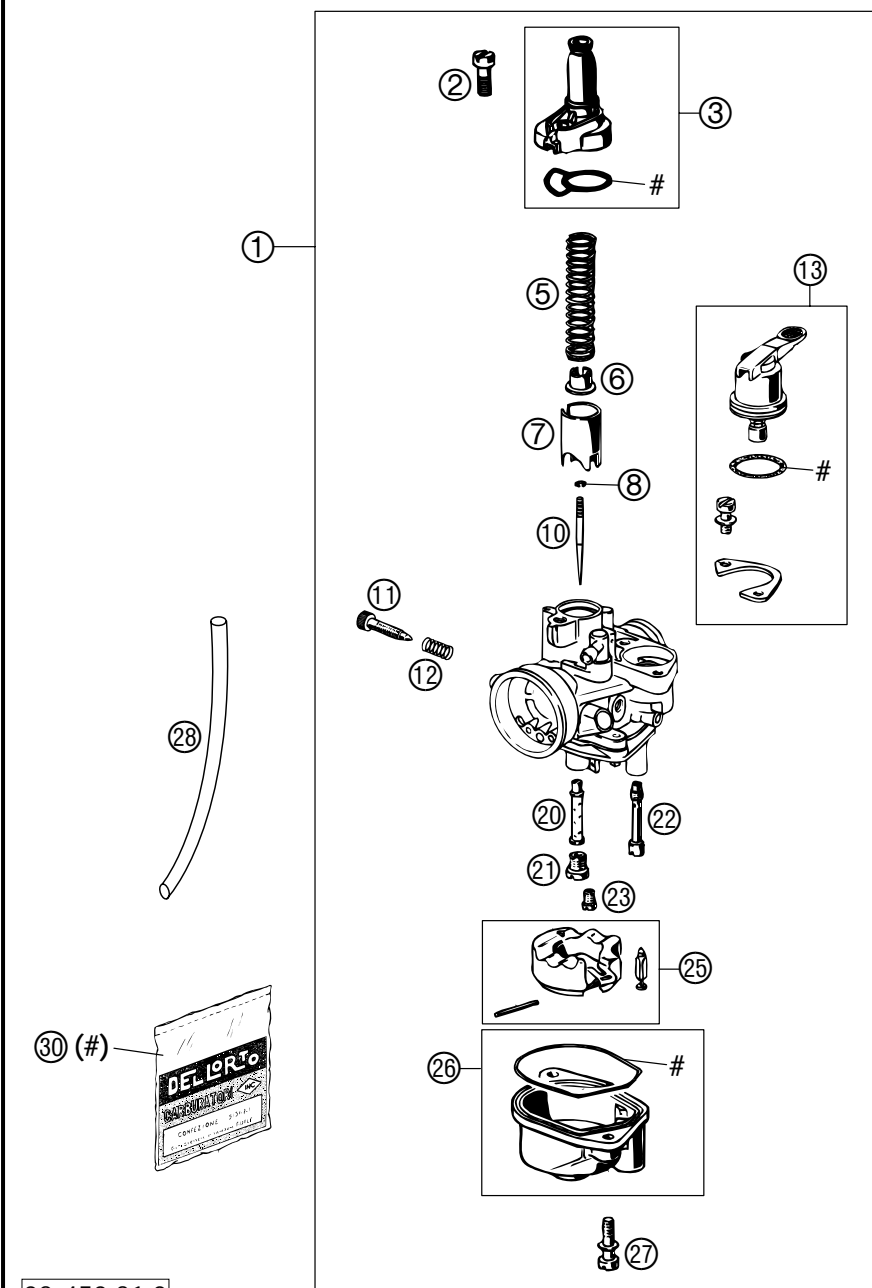

FIG	TEILNR/PARTNR	BEZEICHNUNG	DESCRIPTION	QTY
1	451.31.001.000	VERGASER KPL.DELLO. 14 PHVA DS	CARBURETOR CPL.DELLO.14PHVA DS	1
2	0084 050163	ZYL.SCHRAUBE DIN0084-M 5X16 A	CYL.HEAD SCREW DIN0084-M 5X16A	1
3	451.31.527.000	VERGASERDECKEL DELLORTO 14	CARBURETOR COVER DELLORTO 14	1
5	451.31.530.000	SCHIEBERFEDER	SPRING	1
6	451.31.531.000	FEDERTASSE	SPRING CAP	1
7	451.31.535.000	GASSCHIEBER 40	THROTTLE VALVE 40	1
8	451.31.545.000	KLEMMFEDER	CLAMP SPRING	1
10	451.31.534.010	DÜSENNADEL A10	JET NEEDLE A10	1
11	451.31.517.000	LEERLAUFREGULIERSCHRAUBE	IDLE ADJUST SCREW	1
12	451.31.516.000	FEDER F. LEERLAUFREGULIERSCHR.	SPRING FOR IDLE ADJUST SCREW	1
13	451.31.548.000	STARTHEBEL KPL. DELLORTO 14	STARTING LEVER CPL. DELLORT.14	1
20	451.31.536.000	ZERSTÄUBER 211FA	ATOMIZER 211FA	1
21	590.30.054.000	DÜSE 60 DELLORTO M6X0,75	JET 60 DELLORTO M6X0,75	X
21	451.31.023.070	HAUPTDÜSE 70 DELLORTO	MAIN JET 70 DELLORTO	X
21	451.31.023.080	HAUPTDÜSE 80 DELLORTO	MAIN JET 80 DELLORTO	1
22	451.31.551.060	STARTDÜSE 60	STARTING JET 60	1
23	451.31.507.035	LEERLAUFDÜSE 35	IDLING JET 35	X
23	451.31.507.045	LEERLAUFDÜSE 45	IDLING JET 45	1
25	451.31.509.000	SCHWIMMER KPL.	FLOAT CPL.	1
26	451.31.511.000	SCHWIMMERGEHÄUSE DELLORTO 14	FLOAT BOWL DELLORTO 14	1
27	0084 040203	ZYL.SCHRAUBE DIN0084-M 4X20 A	CYL.SCREW DIN0084-M 4X20 A	2
28	520.31.137.001	PVC-SCHLAUCH 3X5MM	PVC-HOSE 3X5MM	0,24
30	451.31.599.000	DICHTUNGSSATZ DELLO.14 PHVA DS	GASKET SET DELLORTO 14 PHVA DS	1

FIG	TEILNR/PARTNR	BEZEICHNUNG	DESCRIPTION	QTY
4	451.39.004.000	STATOR 50CCM LC 2001	FLYWHEEL STATOR 50CCM LC 2001	1
5	451.39.005.000	ROTOR 50CCM LC 2001	FLYWHEEL ROTOR 50CCM LC 2001	1
6	451.39.006.000	ZÜNDSPULE 50CCM LC 2001	IGNITION COIL 50CCM LC 2001	1
7	0015 060123	SK.BUNDSCHRAUBE M 6X12 SW=8	HH COLLAR SCREW M 6X12 WS=8	2
9	511.39.093.010	ZÜNDKERZE NGK BR8HS	SPARK PLUG NGK BR8HS	1
10	545.31.010.000	KERZENSTECKER LB05EMH NGK	SPARK PLUG CAP LB05EMH NGK	1
12	0912 050253	ISK.SCHRAUBE DIN0912-M 5X25	AH SCREW DIN0912-M 5X25	2
20	451.32.020.000	SCHEIBE 10,4X16,8X0,4	WASHER 10,4X16,8X0,4	1
28	451.30.028.000	SPEZIALMUTTER M10 (HÖHE 6MM)	SPECIAL NUT M10 (HEIGHT 6MM)	1

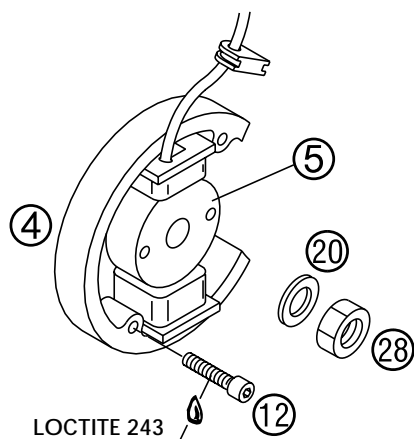

FIG	TEILNR/PARTNR	BEZEICHNUNG	DESCRIPTION	QTY
2	451.32.502.044	FLIEHKRAFTKUPPLUNG KPL.50 2002	CLUTCH CPL.50 2002	1
3	451.32.002.000	KUPPLUNGSNABE 50 LC 2002	CLUTCH HUB 50 LC 2002	1
4	451.32.504.000	DISTANZBÜCHSE 6X8,1X13,5 2002	SPACER 6X8,1X13,5 2002	3
5	451.32.005.000	KUPPLUNGSFEDER 2001	CLUTCH SPRING 2001	X
7	0933 060205	SK.SCHRAUBE DIN0933-M 6X20	HH SCREW DIN933 M6X20	3
11	451.32.011.100	KUPPLUNGSBACKE 50 LC 2002	CLUTCH BLOCK 50 LC 2002	3
15	451.32.015.000	NADELLAGER 15X18X17	NEEDLE BEARING 15X18X17	1
19	451.32.020.030	DISTANZSCHEIBE 15X25X0,3	SPACER WASHER 15X25X0,3	X
19	451.32.020.040	DISTANZSCHEIBE 15X25X0,4	SPACER WASHER 15X25X0,4	X
19	451.32.020.060	DISTANZSCHEIBE 15X25X0,6	SPACER WASHER 15X25X0,6	X
19	451.32.020.080	DISTANZSCHEIBE 15X25X0,8	SPACER WASHER 15X25X0,8	X
20	451.32.020.000	SCHEIBE 10,4X16,8X0,4	WASHER 10,4X16,8X0,4	1
21	451.32.120.000	SCHEIBE 8X15,3X0,5	WASHER 8X15,3X0,5	X
21	451.32.120.100	SCHEIBE 8X15,3X1	WASHER 8X15,3X1	X
23	451.32.023.016	KUPPLUNGSTROMMEL 16-Z	CLUTCH DRUM 16-T	1
29	451.30.029.000	SPEZIALMUTTER 10X1,25X8	SPECIAL NUT 10X1,25X8	1

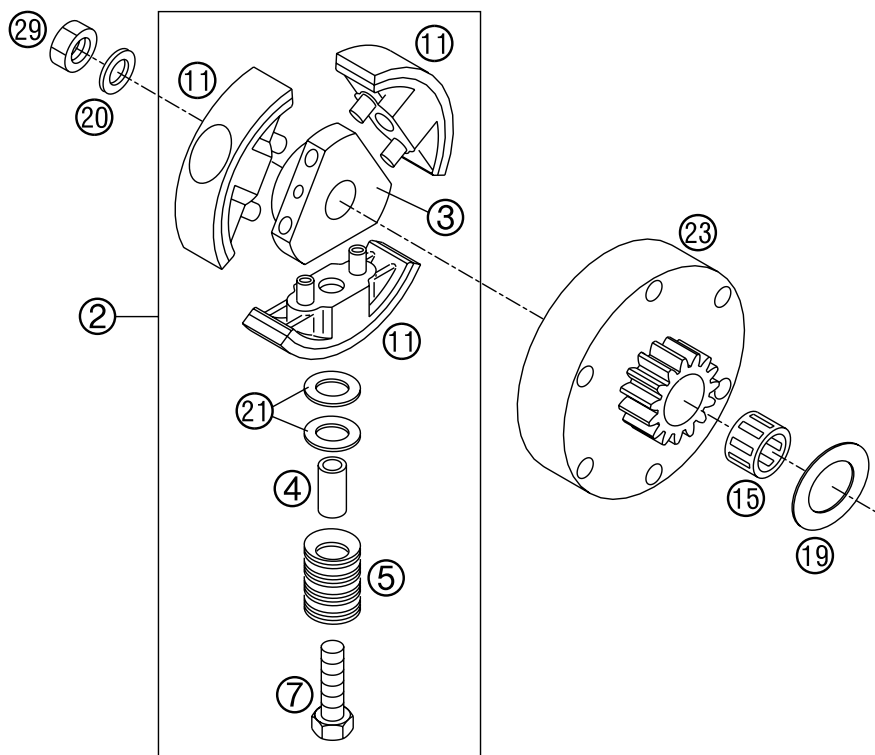

FIG	TEILNR/PARTNR	BEZEICHNUNG	DESCRIPTION	QTY
49	0471 150010	SICHERUNGSRING DIN0471-15X1	CIRCLIP DIN0471-15X1	1
50	451.33.050.000	KICKSTARTERWELLE 50 LC 2001	KICKSTARTER SHAFT 50 LC 2001	1
52	451.33.052.000	SPERRAD FÜR KICKSTARTER 2001	KICKSTARTER SLEEVE 2001	1
54	451.33.054.000	FEDER FÜR KICKSTARTER 2001	KICKSTARTER SPRING 2001	1
56	451.33.056.000	SPERRADFEDER 2001	KICKSTARTER SLEEVE SPRING 2001	1
57	451.33.057.000	O-RING 12,5X1,5	O-RING 12,5X1,5	1
58	451.33.058.000	LAGERBOLZEN FÜR SPERRAD 2001	PIN FOR KICKSTARTER SLEE. 2001	1
59	451.33.059.000	SCHEIBE 16X25X1	WASHER 16X25X1	1
69	0015 060203	SK.BUNDSCHRAUBE M 6X20 SW=8	HH COLLAR SCREW M 6X20 WS=8	1
70	451.33.070.000	KICKSTARTER 50CCM LC 2001	KICKSTARTER 50CCM LC 2001	1

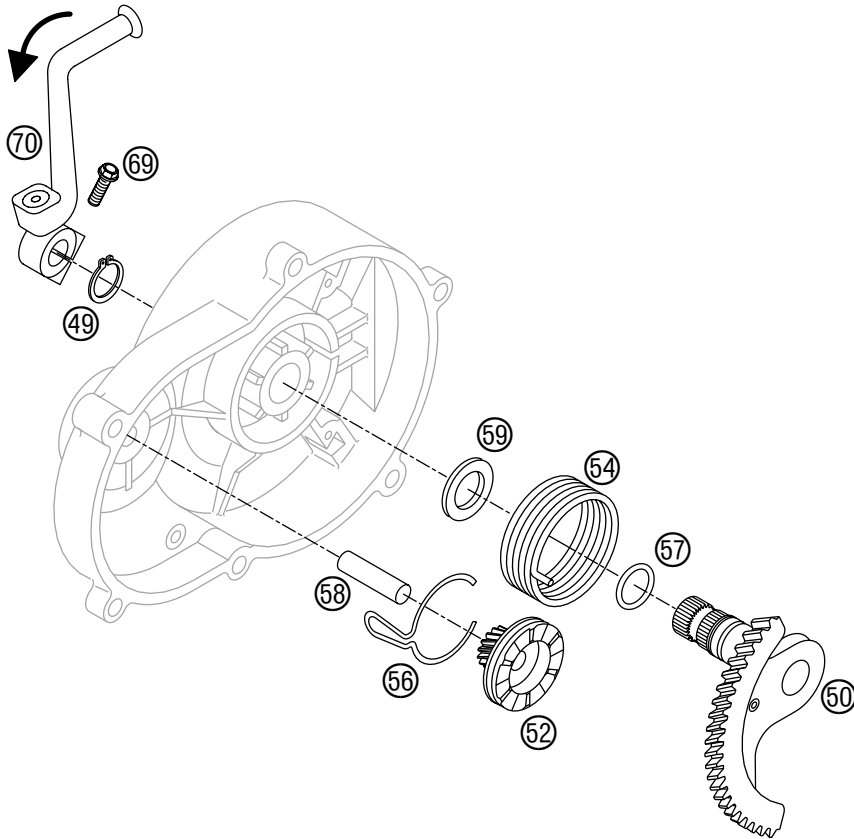

FIG	TEILNR/PARTNR	BEZEICHNUNG	DESCRIPTION	QTY
2	451.33.002.000	ABTRIEBSWELLE 50CCM LC 2001	COUNTER SHAFT 50CCM LC 2001	1
24	451.33.024.000	SCHEIBENFEDER 5X5X12	WOODRUFF KEY 5X5X12	1
25	451.32.024.057	PRIMÄRRAD 57-Z	PRIMARY GEAR 57-T	1
28	451.33.028.000	KUGELLAGER 15X35X11	BALL BEARING 15X35X11	2
29	451.33.029.009	KETTENRITZEL 9-Z 50 LC 2001	SPROCKET 9-T 50 LC 2001	X
29	451.33.029.010	KETTENRITZEL 10-Z 50 LC 2001	SPROCKET 10-T 50 LC 2001	X
29	451.33.029.011	KETTENRITZEL 11-Z 50 LC 2001	SPROCKET 11-T 50 LC 2001	1
29	451.33.029.012	KETTENRITZEL 12-Z 50 LC 2001	SPROCKET 12-T 50 LC 2001	X
29	451.33.029.013	KETTENRITZEL 13-Z 50 LC 2001	SPROCKET 13-T 50 LC 2001	X
30	0471 150010	SICHERUNGSRING DIN0471-15X1	CIRCLIP DIN0471-15X1	1
31	451.33.031.000	WELLENDICHTRING 15X24X5	OIL SEAL RING 15X24X5	1
77	460.30.029.000	SK.MUTTER 14X1,25X7 SW=22	HH NUT 14X1,25X7 WS=22	1
78	460.30.078.000	SICHERUNGSBLECH D=14MM	LOCKING PLATE D=14MM	1

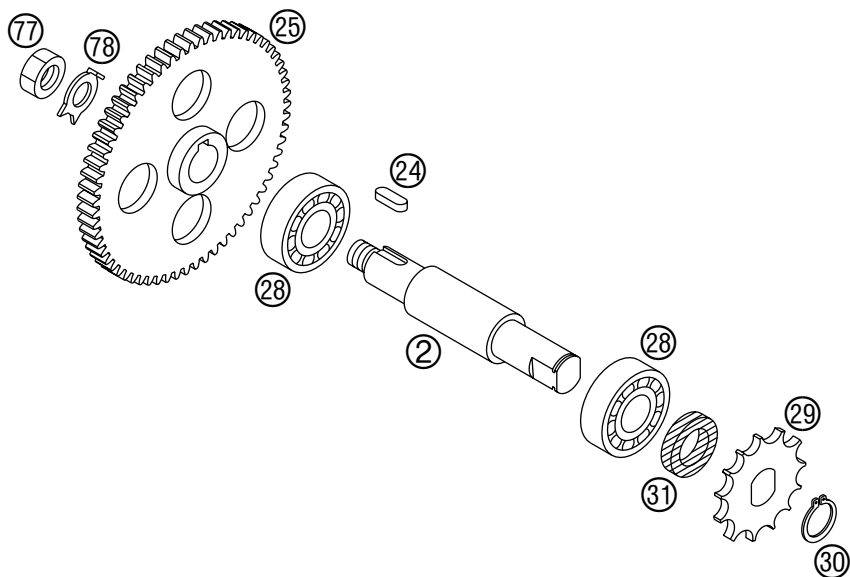

FIG	TEILNR/PARTNR	BEZEICHNUNG	DESCRIPTION	QTY
1	451.30.001.044	KUPPLUNGSDE.F.KICKSTART N.HIN.	CLUTCH C.F.KICK STARTER REAR	1
6	451.33.057.000	O-RING 12,5X1,5	O-RING 12,5X1,5	1
7	460.33.070.100	KICKSTARTER KPL. 60/65 2000	KICKSTARTER CPL. 60/65 2000	1
9	0015 060203	SK.BUNDSCHRAUBE M 6X20 SW=8	HH COLLAR SCREW M 6X20 WS=8	2
11	0603 061001	CU-DICHTRING DIN7603-6X10X1	CU-SEAL RING DIN7603-6X10X1	1
12	0015 060103	SK.BUNDSCHRAUBE M 6X10 SW=8	HH COLLAR SCREW M 6X10 WS=8	1
13	451.30.019.000	DICHTUNG F. ÖLEINFÜLLSCHRAUBE	GASKET FOR OIL PLUG	1
14	451.30.020.000	ÖLEINFÜLLSCHRAUBE 50 LC 2001	OIL PLUG 50 LC 2001	1
15	0015 060163	SK.BUNDSCHRAUBE M 6X16 SW=8	HH COLLAR SCREW M 6X16 WS=8	1

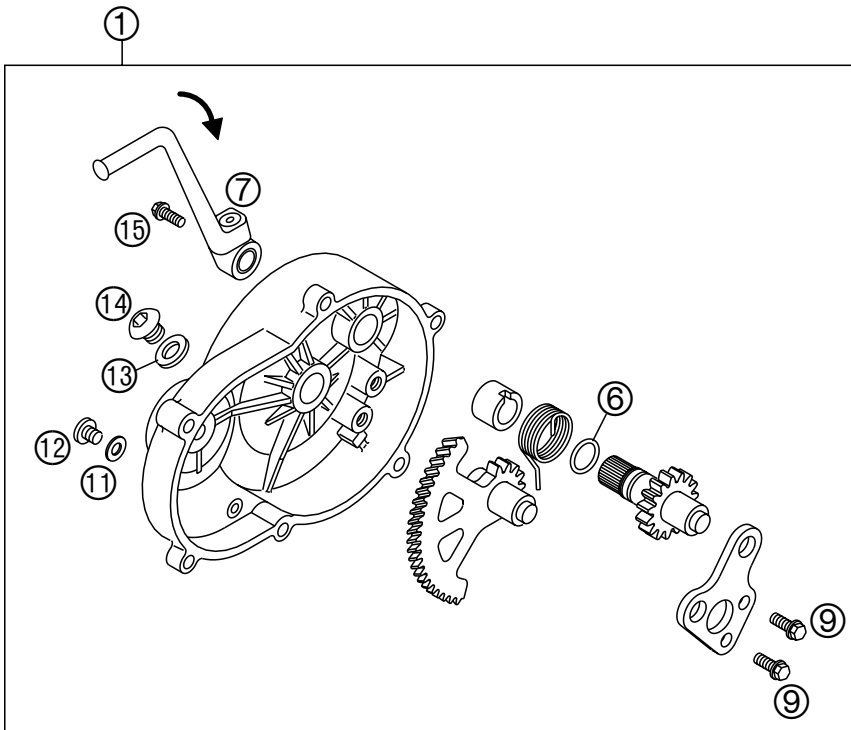
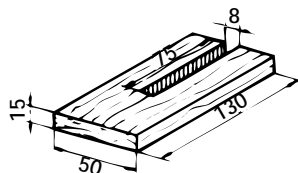
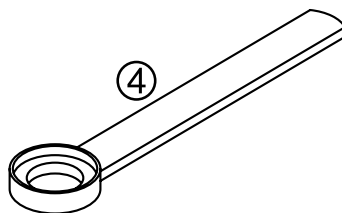
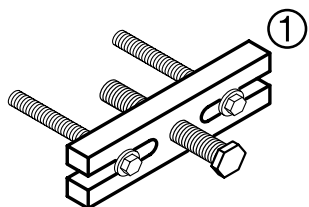

FIG	TEILNR/PARTNR	BEZEICHNUNG	DESCRIPTION	QTY
1	160.12.005.000	ABZIEHER	EXTRACTOR	1
2	6 899 785	LOCTITE 243 BLAU 6CCM	LOCTITE 243 BLUE 6CCM	1
4	451.12.021.000	HALTESCHLÜSSEL F. ROTOR 2002	HOLDING SPANNER F. FLYWHEEL 02	1
5	451.29.006.000	EINSTELLEHRE 50SX MINI 2001	ADJUSTING PLATE 50SX MINI 2001	1



HOLZPLATTE - SELBSTGEFERTIGT
WOODEN PLATE - HOME MADE





NOTIZEN

NOTES



KTM SPORTMOTORCYCLE AG
5230 Mattighofen
Austria
Internet: www.ktm.at

