

SPAREPARTSMANUAL2005

ERSATZTEILKATALOG: FAHRGESTELL + MOTOR
SPARE PARTS MANUAL: CHASSIS + ENGINE

50 MINI ADVENTURE

50 SENIOR ADVENTURE



KTM

TELEGABEL MINI ADVENTURE
FRONT FORK MINI ADVENTURE

4

TELEGABEL SENIOR ADVENTURE
FRONT FORK SENIOR ADVENTURE

5

LENKER, ARMATUREN
HANDLEBAR, CONTROLS

6

HANDBREMSZYLINDER SENIOR ADVENTURE
HAND BRAKE CYLINDER SENIOR ADVENTURE

7

RAHMEN, SEITENSTÄNDER MINI ADVENTURE
FRAME, SIDE STAND MINI ADVENTURE

8

RAHMEN, SEITENSTÄNDER SENIOR ADVENTURE
FRAME, SIDE STAND SENIOR ADVENTURE

9

SCHWINGARM, FEDERBEIN MINI ADVENTURE
SWINGARM, MONOSHOCK MINI ADVENTURE

10

SCHWINGARM, FEDERBEIN SENIOR ADVENTURE
SWINGARM, MONOSHOCK SENIOR ADVENTURE

11

AUSPUFFANLAGE
EXHAUST SYSTEM

12

TANK, SITZBANK, VERKLEIDUNG
TANK, SEAT, COVER

13

MASKE, KOTFLÜGEL
MASK, FENDERS

14

DEKOR
DECAL

15

VORDERRAD MINI ADVENTURE
FRONT WHEEL MINI ADVENTURE

16

VORDERRAD SENIOR ADVENTURE
FRONT WHEEL SENIOR ADVENTURE

17

BREMSZANGE VORNE SENIOR ADVENTURE
BRAKE CALIPER FRONT SENIOR ADVENTURE

18

HINTERRAD MINI ADVENTURE
REAR WHEEL MINI ADVENTURE

19

HINTERRAD SENIOR ADVENTURE
REAR WHEEL SENIOR ADVENTURE

20

ZUBEHÖR
ACCESSORIES

21

MOTORGEHÄUSE
ENGINE CASE

22

KURBELWELLE, KOLBEN
CRANKSHAFT, PISTON

23

ZYLINDER, ZYLINDERKOPF
CYLINDER, CYLINDER HEAD

24

FRISCHÖLSCHMIERUNG MINI ADVENTURE
FRESH OIL LUBRICATION MINI ADVENTURE

25

VERGASER DELLORTO
CARBURETOR DELLORTO

26

ZÜNDANLAGE
IGNITION SYSTEM

27

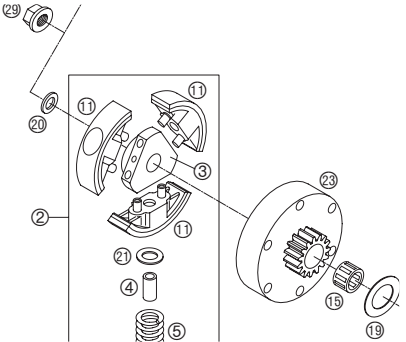
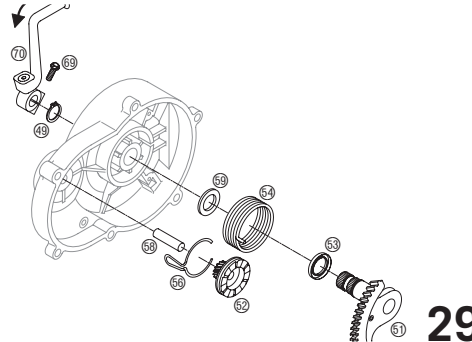
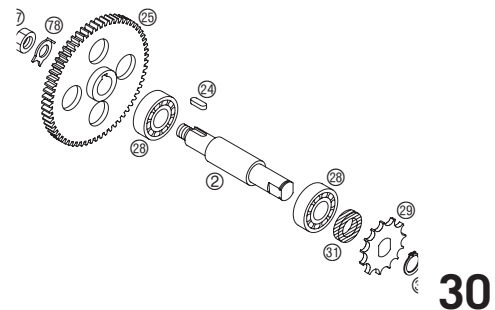
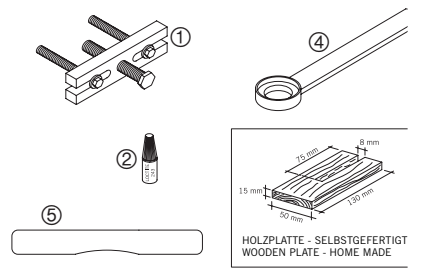
<p>KUPPLUNG CLUTCH</p>  <p>28</p>	<p>KICKSTARTER KICKSTARTER</p>  <p>29</p>	<p>GETRIEBE TRANSMISSION</p>  <p>30</p>	<p>SPEZIALWERKZEUGE SPECIAL TOOLS</p>  <p>31</p>
<div style="display: flex; align-items: center;"> <div style="background-color: #cccccc; width: 60px; height: 100px; display: flex; align-items: center; justify-content: center; margin-right: 20px;"> ! </div> <div> <p>Alle enthaltenen Angaben sind unverbindlich. Die KTM-Sportmotorcycle AG behält sich insbesondere das Recht vor, technische Angaben, Preise, Farben, Formen, Materialien, Dienst- und Serviceleistungen, Konstruktionen, Ausstattungen und ähnliches ohne vorheriger Ankündigung und ohne Angabe von Gründen zu ändern bzw. ersatzlos zu streichen, sie an lokale Gegebenheiten anzupassen sowie die Fertigung eines bestimmten Modells ohne vorherige Ankündigung einzustellen. KTM übernimmt keine Haftung für Liefermöglichkeiten, Abweichungen von Abbildungen und Beschreibungen sowie Druckfehler und Irrtümer. Die abgebildeten Modelle enthalten zum Teil Sonderausstattungen, die nicht zum serienmäßigen Lieferumfang gehören. © 2004 by KTM-SPORTMOTORCYCLE AG, Mattighofen AUSTRIA; Alle Rechte vorbehalten; Nachdruck, auch auszugsweise, nur mit schriftlicher Genehmigung von KTM-SPORTMOTORCYCLE AG, Mattighofen</p> <p><i>All information contained is without obligation. KTM-Sportmotorcycle AG particularly reserves the right to modify any equipment, technical specifications, prices, colors, shapes, materials, services, service work, constructions, equipment and the like so as to adapt them to local conditions or to cancel any of the above items, all without previous announcement and without giving reasons. KTM may stop manufacturing certain models without previous notice. KTM shall not be held liable for any deviations of availability and/or ability to deliver, illustrations, descriptions, printing and/or other errors. The illustrated models partly contain extra equipment, which is not applied to standard models.</i></p> <p>© 2004 by KTM-SPORTMOTORCYCLE AG, Mattighofen AUSTRIA; All rights reserved; Reprint, also in extracts, with written allowance of KTM-SPORTMOTORCYCLE AG, Mattighofen only.</p> </div> </div>			

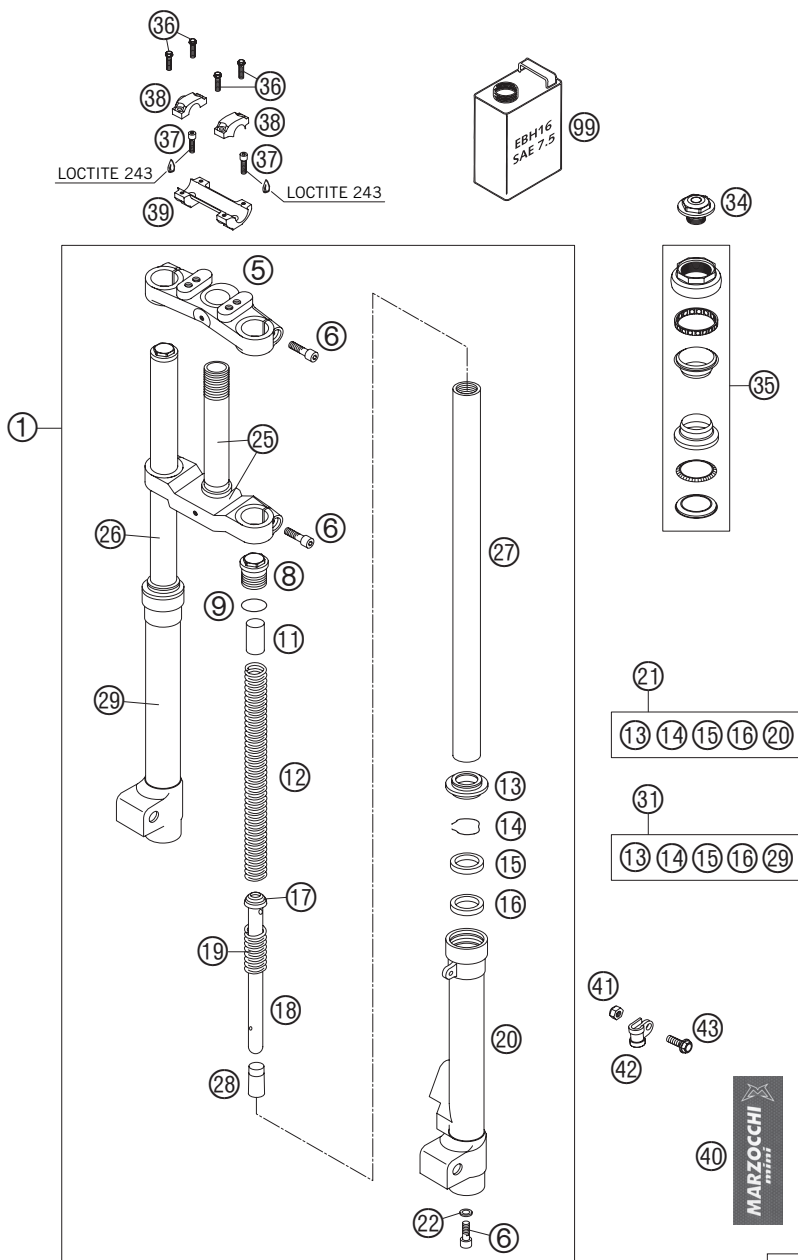

05-450.01.0

FIG	TEILNR/PARTNR	BEZEICHNUNG	DESCRIPTION	QTY
1	451.01.000.044	GABEL KPL. 50 ADV. MARZ. 2002	FORK CPL. 50 ADV. MARZ. 2002	1
5	7501476A	GABELBRÜCKE OBEN	TOP FORK PLATE	1
6	0912 080303	ISK.SCHRAUBE DIN0912-M 8X30	AH SCREW DIN0912-M 8X30	6
8	7504212AC	VERSCHLUSSKAPPE	PLUG CAP	2
9	7528010	O-RING	O-RING	2
11	7518031	VORSPANNBÜCHSE L=55MM 2002	PRE LOAD BUSH L=55MM 2002	2
12	75141169	DRUCKFEDER 2N/MM	SPRING 2N/MM	2
12	75141214	DRUCKFEDER 2,5N/MM	SPRING 2,5N/MM	X
13	7533297	STAUBMANSCHETTE	DUST SEAL	2
14	7523264	SICHERUNGSRING	STOP RING	2
15	7528230	SIMMERRING 32/42/6,5-9,5	OIL SEAL 32/42/6,5-9,5	2
16	7522166AA	SCHIBE D42X32,5X1,5	WASHER D42X32,5X1,5	2
17	7524157	KOLBENRING D32 NUR BEI ZUGSTUFE	PISTON RING D32 ONLY FOR REBOUND DAMPING	1
18	78031105	KOLBENSTANGE ZUGSTUFE MINI 02 ZUGSTUFE - LINKE SEITE	PISTON ROD REBOUND MINI 02 REBOUND DAMPING - LEFT SIDE	1
18	78031104	KOLBENSTANGE DRUCKSTU. MINI 02 DRUCKSTUFE - RECHTE SEITE	PISTON ROD COMPRESSION MINI 02 COMPRESSION DAMP.- RIGHT SIDE	1
19	75141015	FEDER RÜCKANSCHLAG	REBOUND SPRING	2
20	75031538A/A	GLEITROHR LINKS 2002	SLIDER LEFT SIDE 2002	1
21	75031538A/A/R	GLEITROHR LINKS KPL. 2002	SLIDER LEFT SIDE CPL. 2002	1
22	7522225	SCHIBE 14X8X1,5	WASHER 14X8X1,5	2
25	77051124	GABELBRÜCKE UNT. KPL. MINI/JUN	BOT. FORK PLATE CPL. MINI/JUN	1
26	7708247/R	GABELHOLM RECHTS MINI/JUN. 02	FORK TUBE R/S MINI/JUN. 02	1
27	7708248/R	GABELHOLM LINKS MINI/JUN. 02	FORK TUBE L/S MINI/JUN. 02	1
28	7512068	DÄMPFUNGSROLLE	FOOT BUFFER	2
29	75031366A/A	GLEITROHR RECHTS	SLIDER RIGHT SIDE	1
31	75031366A/K/R	GLEITROHR KPL. RECHTS	SLIDER CPL. RIGHT SIDE	1
34	503.01.036.000	STEUERKOPFSCHR. M20X1,5 SW=27	STEER.HEAD SCREW M20X1,5 WS=27	1
35	451.01.081.100	STEUERSATZ KPL. 50 SXR 2003	STEER.STEM B. CPL. 50 SXR 2003	1
36	0015 080303	SK.BUNDSCHRAUBE M 8X30 SW=10	HH COLLAR SCREW M 8X30 WS=10	4
37	0912 100250	ISK.SCHR.DIN6912 M10X25 10.9 S	AH SCREW DIN6912-M10X25,10.9,L	2
38	503.01.038.000	LENKERKLEMMBRÜCKE D=22MM 2001	HANDLEBAR CLAMP D=22MM 2001	2
39	451.01.039.000	LENKERAUFNABME D=22MM 2001	HANDLEBAR SUPPORT D=22MM 2001	1
40	7547325	AUFKLEBER LINKS MARZOCCHI	STICKER LEFT SIDE MARZOCCHI	1
40	7547331	AUFKLEBER RECHTS MARZOCCHI	STICKER RIGHT SIDE MARZOCCHI	1
41	0985 050003	SS.MÜTTER DIN 985 M5	SELF LOCKING NUT DIN0985-M 5	1
42	450.01.070.000	SCHELLE RSGU 9/12	BRAKE CABLE CLAMP RSGU 9/12	1
43	0015 050203	SK.BUNDSCHRAUBE M 5X20 SW=8	HH COLLAR SCREW M 5X20 WS=8	1
99	7550013	GABELÖL EBH16 SAE 7.5	FORKOIL EBH16 SAE 7.5	1

05-450.01.0

* NEUTEIL / NEW PART X NACH BEDARF / AS REQUIRED

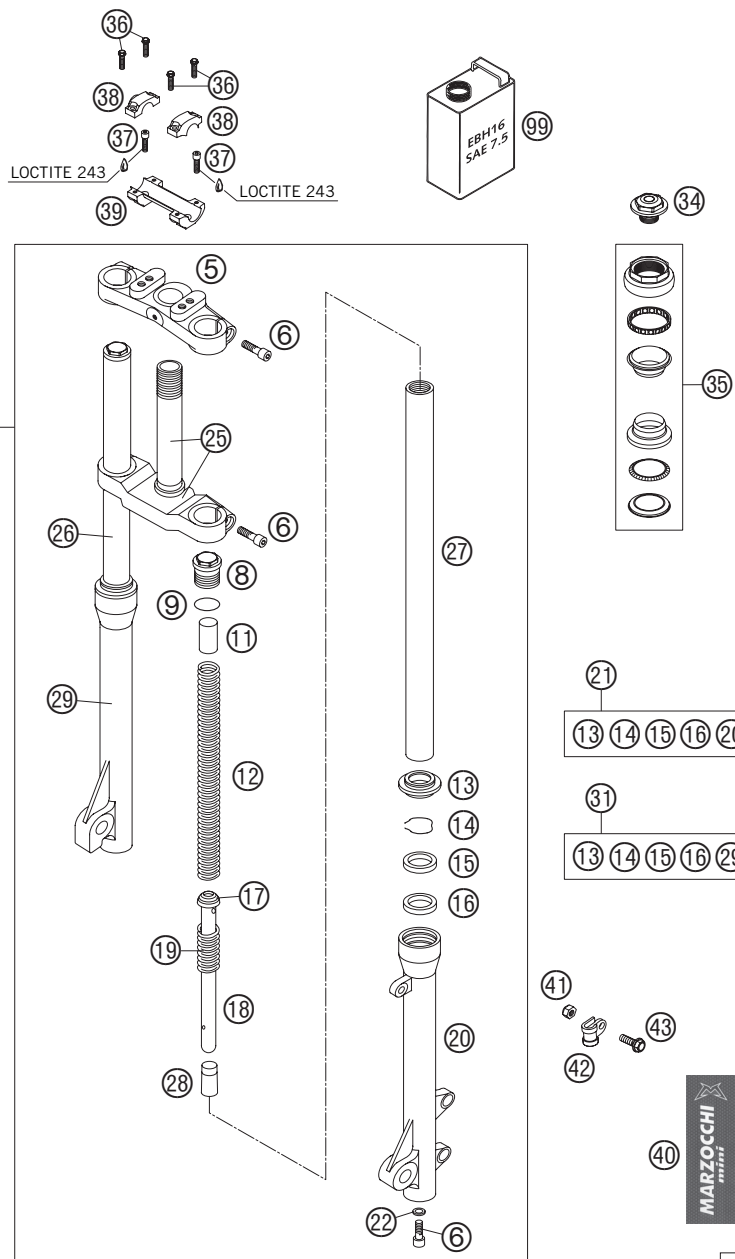

05-450.01.1

FIG	TEILNR/PARTNR	BEZEICHNUNG	DESCRIPTION	QTY
1	451.01.000.544	GABEL KPL. SX SEN. MARZ. 2002	FORK CPL. SX SEN. MARZ. 2002	1
5	7501476A	GABELBRÜCKE OBEN	TOP FORK PLATE	1
6	0912 080303	ISK.SCHRAUBE DIN0912-M 8X30	AH SCREW DIN0912-M 8X30	6
8	7504212AC	VERSCHLUSSKAPPE	PLUG CAP	2
9	7528010	O-RING	O-RING	2
11	7518076	VORSPANNBÜCHSE 25X2,5X100	PRE LOAD BUSH 25X2,5X100	2
12	75141169	DRUCKFEDER 2N/MM	SPRING 2N/MM	2
12	75141214	DRUCKFEDER 2,5N/MM	SPRING 2,5N/MM	X
13	7533297	STAUBMANSCHETTE	DUST SEAL	2
14	7523264	SICHERUNGSRING	STOP RING	2
15	7528230	SIMMERRING 32/42/6,5-9,5	OIL SEAL 32/42/6,5-9,5	2
16	7522166AA	SCHIBE D42X32,5X1,5	WASHER D42X32,5X1,5	2
17	7524157	KOLBENRING D32 NUR BEI ZUGSTUFE	PISTON RING D32 ONLY FOR REBOUND DAMPING	1
18	78031047	KOLBENSTANGE ZUGSTUFE SEN. 01 ZUGSTUFE - LINKE SEITE	PISTON ROD REBOUND SEN. 01 REBOUND DAMPING - LEFT SIDE	1
18	78031045	KOLBENSTANGE DRUCKSTUFE SEN.01 DRUCKSTUFE - RECHTE SEITE	PISTON ROD COMPRESSION SEN.01 COMPRESSION DAMP.- RIGHT SIDE	1
19	75141015	FEDER RÜCKANSCHLAG	REBOUND SPRING	2
20	75031570A	GLEITROHR LINKS 50 LC 2002	SLIDER L/S 50 LC 2002	1
21	75031570A/R	GLEITROHR KPL. LINKS 50LC 2002	SLIDER CPL. L/S 50LC 2002	1
22	7522225	SCHIBE 14X8X1,5	WASHER 14X8X1,5	2
25	77051095	GABELBRÜCKE UNTEN KPL. SEN. 01	BOT. FORK PLATE CPL. SEN. 01	1
26	7708249/R	GABELHOLM RECHTS SENIOR 02	FORK TUBE R/S SENIOR 02	1
27	7708250/R	GABELHOLM LINKS SENIOR 02	FORK TUBE L/S SENIOR 02	1
28	7512068	DÄMPFUNGSROLLE	FOOT BUFFER	2
29	75031571A	GLEITROHR RECHTS 50 LC 2002	SLIDER R/S 50 LC 2002	1
31	75031571A/R	GLEITROHR KPL.RECHTS 50LC 2002	SLIDER CPL. R/S 50LC 2002	1
34	503.01.036.000	STEUERKOPFSCHR. M20X1,5 SW=27	STEER.HEAD SCREW M20X1,5 WS=27	1
35	451.01.081.100	STEUERSATZ KPL. 50 SXR 2003	STEER.STEM B. CPL. 50 SXR 2003	1
36	0015 080303	SK.BUNDSCHRAUBE M 8X30 SW=10	HH COLLAR SCREW M 8X30 WS=10	4
37	0912 100250	ISK.SCHR.DIN6912 M10X25 10.9 S	AH SCREW DIN6912-M10X25,10.9,L	2
38	503.01.038.000	LENKERKLEMMBRÜCKE D=22MM 2001	HANDLEBAR CLAMP D=22MM 2001	2
39	451.01.039.000	LENKERAUFNAHME D=22MM 2001	HANDLEBAR SUPPORT D=22MM 2001	1
40	7547325	AUFKLEBER LINKS MARZOCCHI	STICKER LEFT SIDE MARZOCCHI	1
40	7547331	AUFKLEBER RECHTS MARZOCCHI	STICKER RIGHT SIDE MARZOCCHI	1
41	0985 050003	SS.MÜTTER DIN 985 M5	SELF LOCKING NUT DIN0985-M 5	1
42	450.01.070.000	SCHELLE RSGU 9/12	BRAKE CABLE CLAMP RSGU 9/12	1
43	0015 050203	SK.BUNDSCHRAUBE M 5X20 SW=8	HH COLLAR SCREW M 5X20 WS=8	1
99	7550013	GABELÖL EBH16 SAE 7.5	FORKOIL EBH16 SAE 7.5	1

05-450.01.1

* NEUTEIL / NEW PART X NACH BEDARF / AS REQUIRED

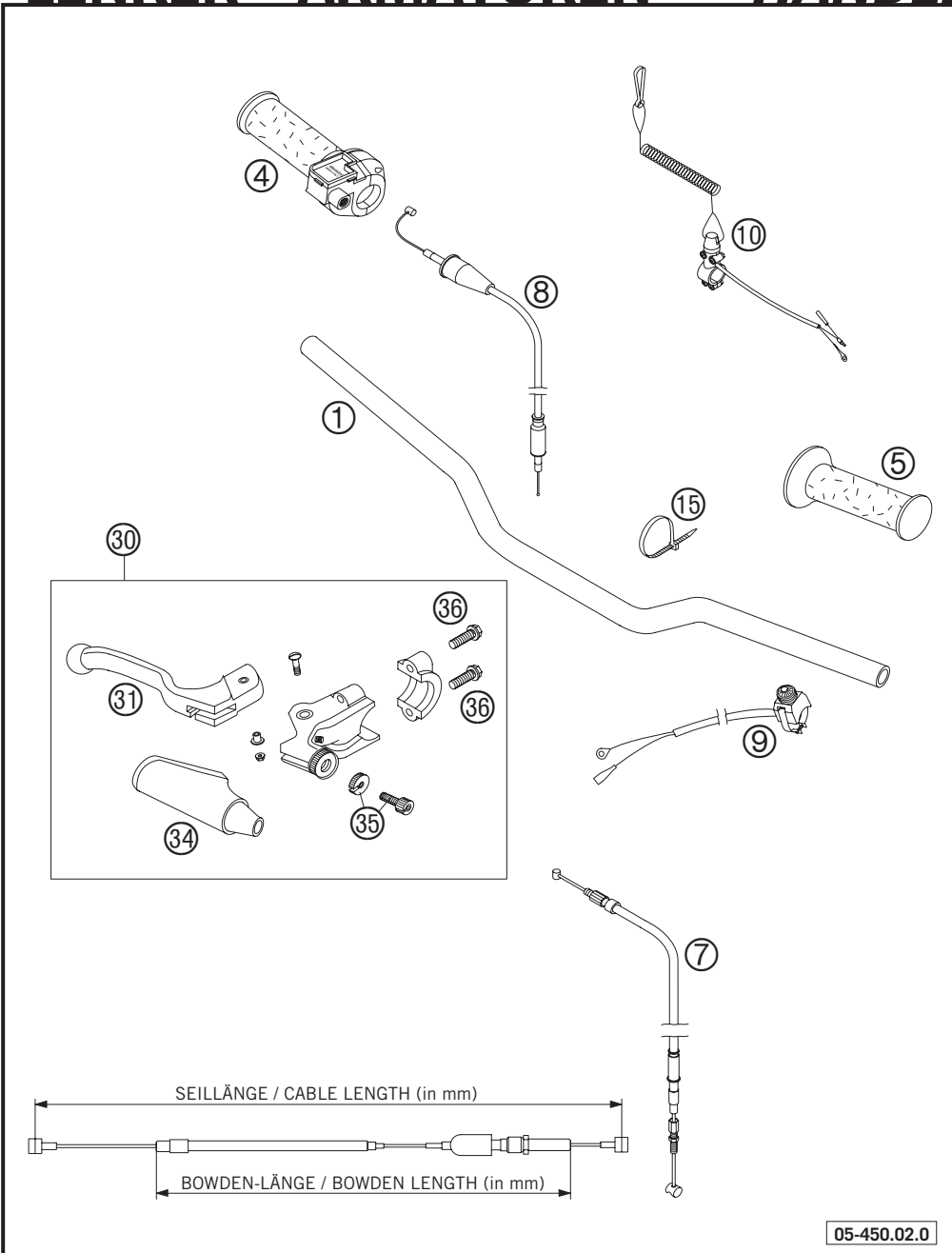

FIG	TEILNR/PARTNR	BEZEICHNUNG	DESCRIPTION	QTY
1*	451.02.001.000	LENKER 50 AC+LC 2005	HANDLEBAR 50 AC+LC 2005	1
4	450.02.010.000	GASDREHGRIF KPL. 50 SXR	TWIST GRIP CPL. 50 SXR	1
5	450.02.039.000	FESTGRIF	RUBBER GRIP	1
7	451.13.010.000	BREMSEIL VORNE 898/772 01 MINI ADV.	BRAKE CABLE FRONT 898/772 01 MINI ADV.	1
7	451.13.070.000	BREMSEIL HINTEN 1187/1052 01 MINI ADV.	BRAKE CABLE REAR 1187/1052 01 MINI ADV.	1
7	451.13.070.100	BREMSEIL HINTEN 1287/1152 01 SENIOR ADV.	BRAKE CABLE REAR 1287/1152 01 SENIOR ADV.	1
8	451.02.091.100	GASSEIL JUNIOR 762/644 2002 MINI ADV.	THROTTLE CABLE JUN.762/644 02 MINI ADV.	1
8	451.02.091.000	GASSEIL SENIOR 849/726 2001 SENIOR ADV.	THROTTLE CABLE SEN.849/726 01 SENIOR ADV.	1
9	503.11.089.200	KURZSCHLUSSSCHALTER 02	SHORT CIRCUIT BUTTON 02	1
10	450.11.089.044	KURZSCHL.SCHALTER M.REISSLEINE	S.CIRCUIT BUTTON W. RIP CORD	X
15	440.11.076.200	KABELBAND 200/3,6MM SCHWARZ	CABLE TIE 200/3,6MM BLACK	X
15	440.11.076.100	KABELBAND 100/2,5MM SCHWARZ	CABLE TIE 100/2,5MM BLACK	X
30	451.13.001.044	HANDBREMSHEBEL KPL. RE. 2001 MINI ADV.	HAND BRAKE LEVER CPL. R/S 2001 MINI ADV.	1
30	460.02.040.100	KUPPLUNGSH. KPL. 60/65 SX '99 HANDBREMSHEBEL LINKS	CLUTCH LEVER CPL. 60/65 SX '99 HAND BRAKE LEVER L/S	1
31	451.13.042.000	HANDBREMSHEBEL LOSE 2001 MINI ADV.	HAND BRAKE LEVER LOOSE 2001 MINI ADV.	1
31	460.02.042.100	KUPPLUNGSH. LOSE 60/65 SX '99 HANDBREMSHEBEL LINKS	CLUTCH LEVER LOOSE 60/65SX '99 HAND BRAKE LEVER L/S	1
34	460.02.048.000	SCHUTZKAPPE FÜR KUPPLUNGSH. 2000	PLASTIC CAP FOR CLUTCH LEVER	2(1)
35	460.02.043.100	STELLSCHRAUBE KUPPLUNGSH. 2000	ADJUST SCREW CLUTCH LEVER 2000	2(1)
36	0015 060203	SK.BUNDSCHRAUBE M 6X20 SW=8	HH COLLAR SCREW M 6X20 WS=8	4(2)

* NEUTEIL / NEW PART X NACH BEDARF / AS REQUIRED

HANDBREMSZYLINDER » *HAND BRAKE CYLINDER*

50 SENIOR ADV. / 2005

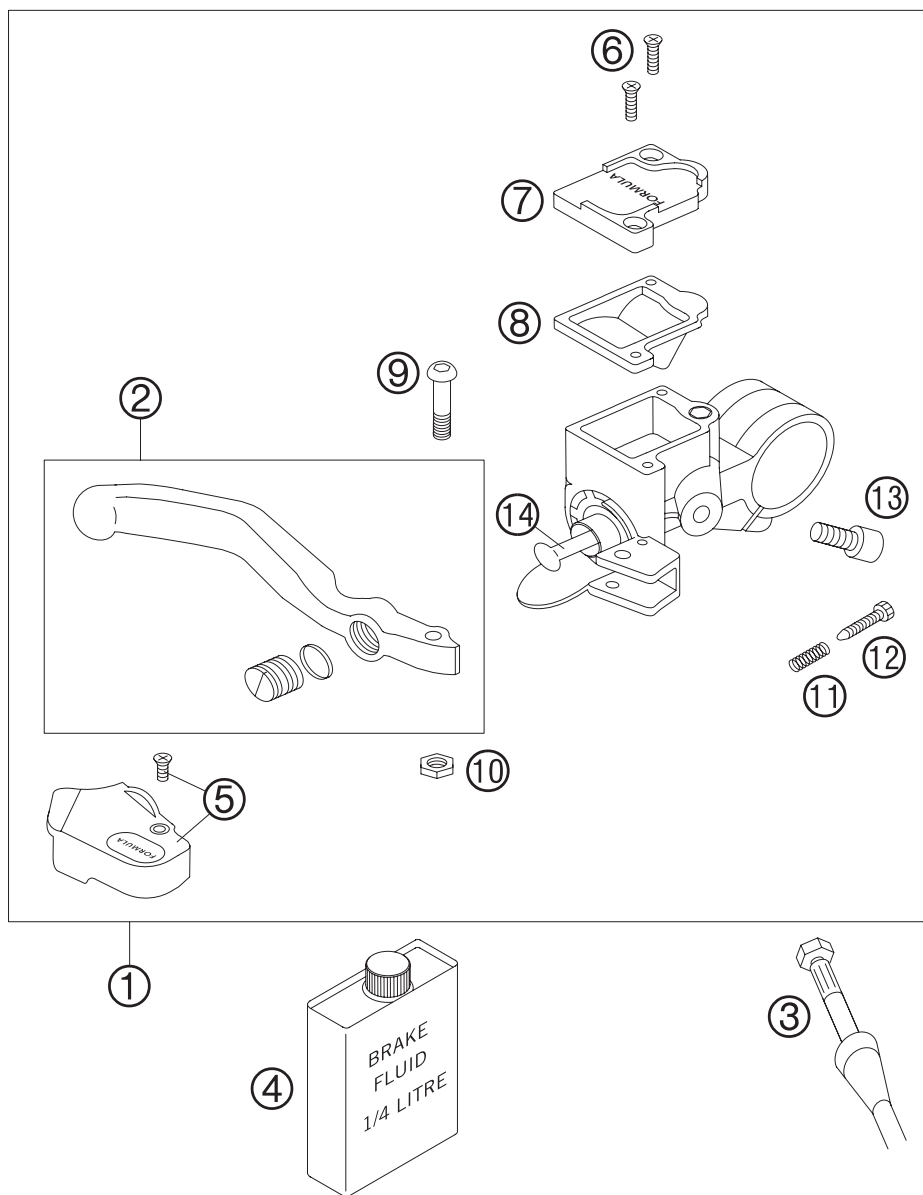

FIG	TEILNR/PARTNR	BEZEICHNUNG	DESCRIPTION	QTY
1	451.13.101.044	HANDBREMSZYLINDER KPL.50 LC 02	HAND BRAKE CYLIND.CPL.50 LC 02	1
2	451.13.002.000	HANDBREMSHEBEL KPL. RECHTS 02	HANDBRAKE LEVER CPL. R/S 02	1
3	451.13.012.100	BREMSSCHL.VO. SX SEN. LC 2002	BRAKE HOSE FR. SX SEN. LC 2002	1
4	306054	BREMSSCHL.VO. SX SEN. LC 2002	BRAKE HOSE FR. SX SEN. LC 2002	1
5	451.13.004.000	SCHUTZKAPPE HANDBREMSZ. 50 LC	PROT.CAP HAND BRAKE CYL. 50 LC	1
6	0966 030083	LI.SENKSCHRAUBE DIN0966-M 3X8	OVAL HEAD SCREW DIN0966-M 3X8	2
7	451.13.003.000	HANDBREMSZYLINDERDECKEL 50 04	HAND BRAKE CYLINDER COVER 04	1
8	451.13.009.000	DICHTUNG HANDBREMSZYLINDER 04	GASKET HAND BRAKE CYLINDER 04	1
9	451.13.006.000	SPEZIAL-ISK.SCHRAUBE M 5X18	SPECIAL-AH SCREW M 5X18	1
10	451.13.013.000	MUTTER M5 DIN 6334	NUT M5 DIN 6334	1
11	451.13.021.000	FEDER FÜR HANDBREMSHEBEL 04	SPRING FOR HAND BRAKE LEVER 04	1
12	451.13.007.000	EINSTELLSCHRAUBE M 3X16 04	ADJUSTING SCREW M 3X16 04	1
13	0912 050103	ISK.SCHRAUBE DIN 912 M5X10	AH SCREW DIN0912-M 5X10	1
14	451.13.008.000	REP.SATZ KOLBEN VORNE 50 04	REP.KIT PISTON FRONT 50 04	1

05-450.13.0

05-450.13.0

* NEUTEIL / NEW PART X NACH BEDARF / AS REQUIRED

RAHMEN · SEITENSTÄNDER » FRAME · SIDE STAND

50 MINI ADV. / 2005

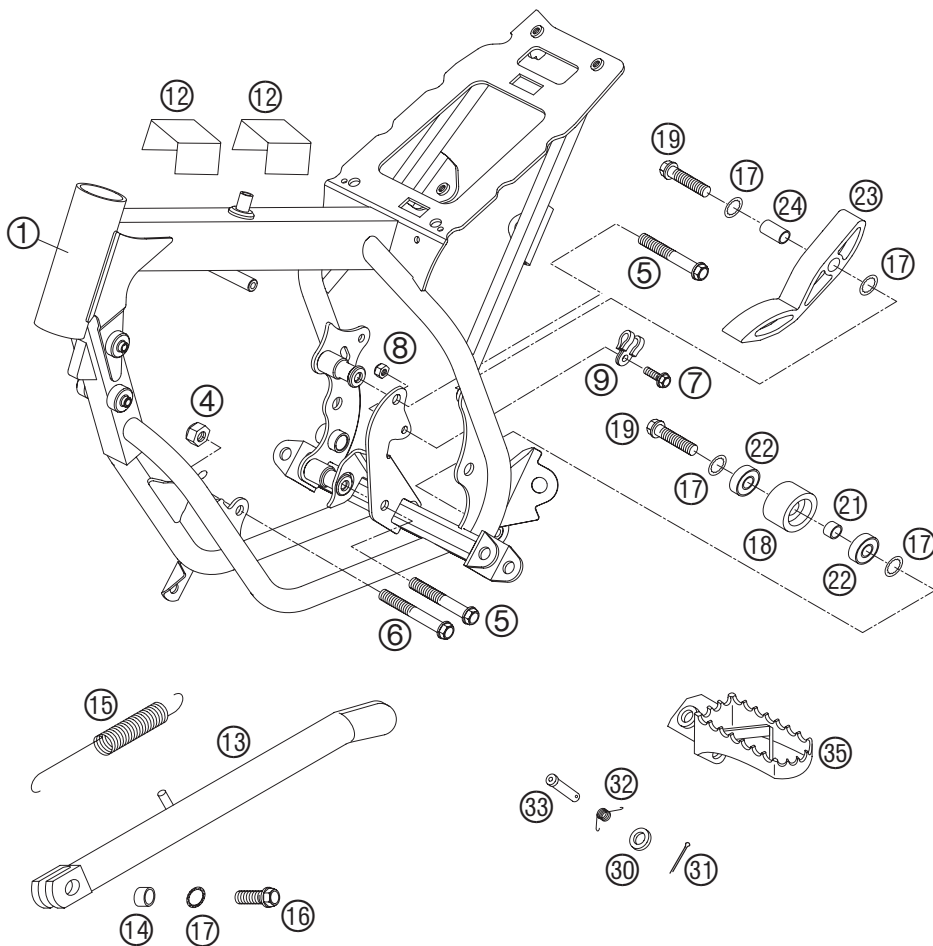

04-450.03.0

04-450.03.0

FIG	TEILNR/PARTNR	BEZEICHNUNG	DESCRIPTION	QTY
1	451.03.001.500	RAHMEN ADVENTURE GS "MF3R" 03	FRAME ADVENTURE GS "MF3R" 03	1
4	543.10.086.200	STOVER-FLANSMUTTER M8 10.9	SELF LOCKING NUT M8 10.9	1
5	0015 080603	SK.BUNDSCHRAUBE M 8X60 SW=10	HH COLLAR SCREW M 8X60 WS=10	2
6	0015 080653	SK.BUNDSCHRAUBE M 8X65 SW=10	HH COLLAR SCREW M 8X65 WS=10	1
7	0015 050123	SK.BUNDSCHRAUBE M 5X12 SW=8	HH COLLAR SCREW M 5X12 WS=8	1
8	0985 050003	SS.MUTTER DIN 985 M5	SELF LOCKING NUT DIN0985-M 5	1
9	450.01.070.000	SCHELLE RSGU 9/12	BRAKE CABLE CLAMP RSGU 9/12	1
12	587.11.054.050	METAMOLL F. BATTERIEHALTEBÜGEL	METAMOLL FOR BATTERY BRACKET	2
13	451.03.023.100/90	SEITENSTÄND.L=270MM SILBER 02	SIDE STAND L=270MM SILVER 02	1
14	451.03.023.250	BÜCHSE F. SEITENSTÄNDER 02	BUSHING FOR SIDE STAND 02	1
15	510.03.021.000	STÄNDERFEDER L=118 MM	SIDESTAND SPRING LONG	1
16	0015 080203	SK.BUNDSCHRAUBE M 8X20 SW=10	HH COLLAR SCREW M 8X20 WS=10	1
17	360.03.014.000	SCHNORR-SICHERUNGSSCHEIBE 8MM	LOCK WASHER 8MM	5
18	502.03.053.000	KETTENROLLE D=30MM	CHAIN ROLL D=30MM	1
19	0015 080303	SK.BUNDSCHRAUBE M 8X30 SW=10	HH COLLAR SCREW M 8X30 WS=10	2
21	740.03.021.000	BÜCHSE 8.2 X 12 X 6	BUSHING 8.2 X 12 X 6	1
22	0625 006087	RILLENKUGELLAGER 608 2RS C3	GROOVED BALL BEAR. 608 2RS C3	2
23	511.03.053.000	KETTENGLEITSTÜCK UNTEN '97	CHAIN SLIDING PIECE BELOW '97	1
24	511.03.053.051	BÜCHSE 8,2X10X20	BUSHING 8,2X10X20	1
30	0125 100003	UNTERLEGSSCHEIBE DIN 125 A 10,5	WASHER DIN0125-A10,5	2
31	0094 032253	SPLINT DIN0094-3,2X25 STAHL	PIN DIN0094-3,2X25 STEEL	2
32	546.03.041.000	FUSSRASTENFEDER LINKS & RECHTS	FOOTREST SPRING L/S & R/S	2
33	548.03.044.000	BOLZEN FÜR FUSSRASTE 03	BOLT FOR FOOT PED 03	2
35	546.03.040.000/90	FUSSRASTE LINKS SILBER	FOOT REST L/S SILVER	1
35	546.03.140.000/90	FUSSRASTE RECHTS SILBER '98	FOOT REST R/S SILVER '98	1

* NEUTEIL / NEW PART X NACH BEDARF / AS REQUIRED

RAHMEN · SEITENSTÄNDER » FRAME · SIDE STAND

50 SENIOR ADV. / 2005

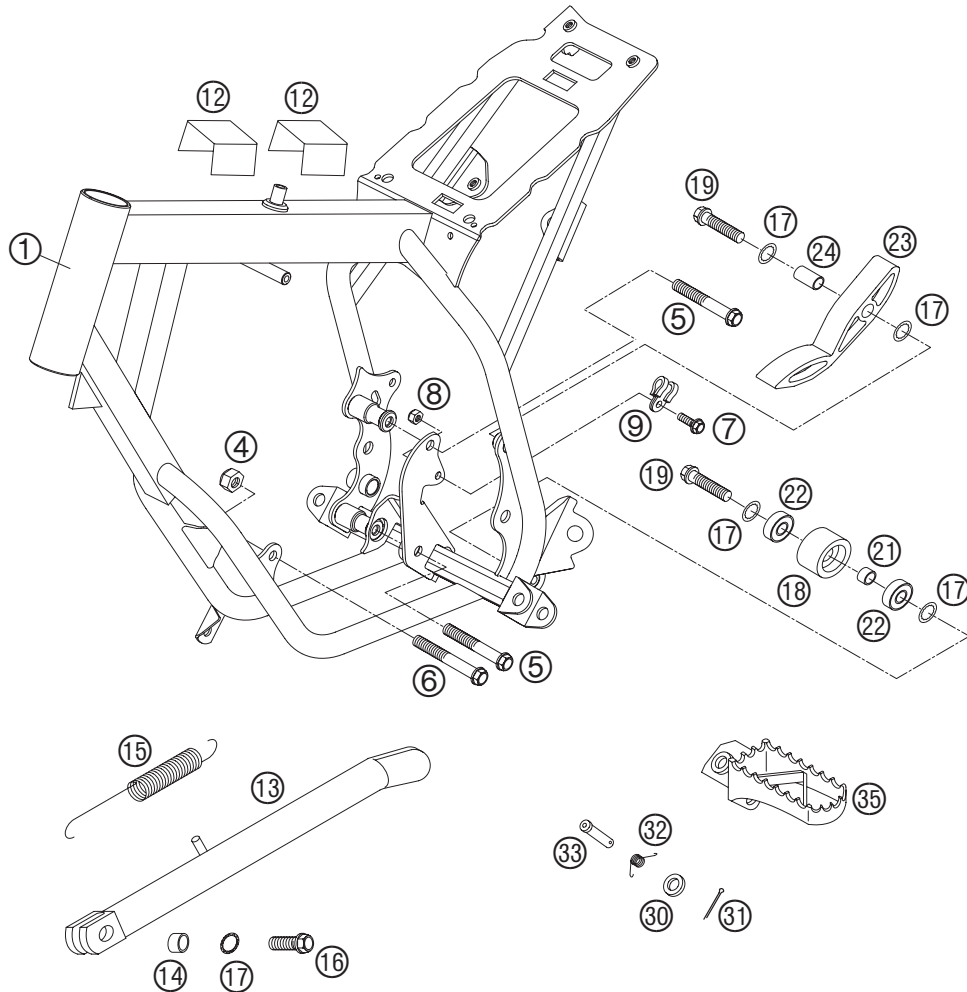

04-450.03.1

FIG	TEILNR/PARTNR	BEZEICHNUNG	DESCRIPTION	QTY
1	451.03.001.300	RAHMEN SENIOR ADV. "MB2R" 2002	FRAME SENIOR ADV. "MB2R" 2002	1
4	543.10.086.200	STOVER-FLANSMUTTER M8 10.9	SELF LOCKING NUT M8 10.9	1
5	0015 080603	SK.BUNDSCHRAUBE M 8X60 SW=10	HH COLLAR SCREW M 8X60 WS=10	2
6	0015 080653	SK.BUNDSCHRAUBE M 8X65 SW=10	HH COLLAR SCREW M 8X65 WS=10	1
7	0015 050123	SK.BUNDSCHRAUBE M 5X12 SW=8	HH COLLAR SCREW M 5X12 WS=8	1
8	0985 050003	SS.MUTTER DIN 985 M5	SELF LOCKING NUT DIN0985-M 5	1
9	450.01.070.000	SCHELLE RSGU 9/12	BRAKE CABLE CLAMP RSGU 9/12	1
12	587.11.054.050	METAMOLL F. BATTERIEHALTEBÜGEL	METAMOLL FOR BATTERY BRACKET	2
13	451.03.023.000/90	SEITENSTÄND.L=319MM SILBER 01	SIDE STAND L=319MM SILVER 2001	1
14	451.03.023.250	BÜCHSE F. SEITENSTÄNDER 02	BUSHING FOR SIDE STAND 02	1
15	510.03.021.000	STÄNDERFEDER L=118 MM	SIDESTAND SPRING LONG	1
16	0015 080203	SK.BUNDSCHRAUBE M 8X20 SW=10	HH COLLAR SCREW M 8X20 WS=10	1
17	360.03.014.000	SCHNORR-SICHERUNGSSCHEIBE 8MM	LOCK WASHER 8MM	5
18	502.03.053.000	KETTENROLLE D=30MM	CHAIN ROLL D=30MM	1
19	0015 080303	SK.BUNDSCHRAUBE M 8X30 SW=10	HH COLLAR SCREW M 8X30 WS=10	2
21	740.03.021.000	BÜCHSE 8.2 X 12 X 6	BUSHING 8.2 X 12 X 6	1
22	0625 006087	RILLENKUGELLAGER 608 2RS C3	GROOVED BALL BEAR. 608 2RS C3	2
23	511.03.053.000	KETTENGLEITSTÜCK UNTEN '97	CHAIN SLIDING PIECE BELOW '97	1
24	511.03.053.051	BÜCHSE 8,2X10X20	BUSHING 8,2X10X20	1
30	0125 100003	UNTERLEGSSCHEIBE DIN 125 A 10,5	WASHER DIN0125-A10,5	2
31	0094 032253	SPLINT DIN0094-3,2X25 STAHL	PIN DIN0094-3,2X25 STEEL	2
32	546.03.041.000	FUSSRASTENFEDER LINKS & RECHTS	FOOTREST SPRING L/S & R/S	2
33	548.03.044.000	BOLZEN FÜR FUSSRASTE 03	BOLT FOR FOOT PED 03	2
35	546.03.040.000/90	FUSSRASTE LINKS SILBER	FOOT REST L/S SILVER	1
35	546.03.140.000/90	FUSSRASTE RECHTS SILBER '98	FOOT REST R/S SILVER '98	1

04-450.03.1

* NEUTEIL / NEW PART X NACH BEDARF / AS REQUIRED

SCHWINGARM · FEDERBEIN » SWINGARM · MONOSHOCK

50 MINI ADV. / 2005

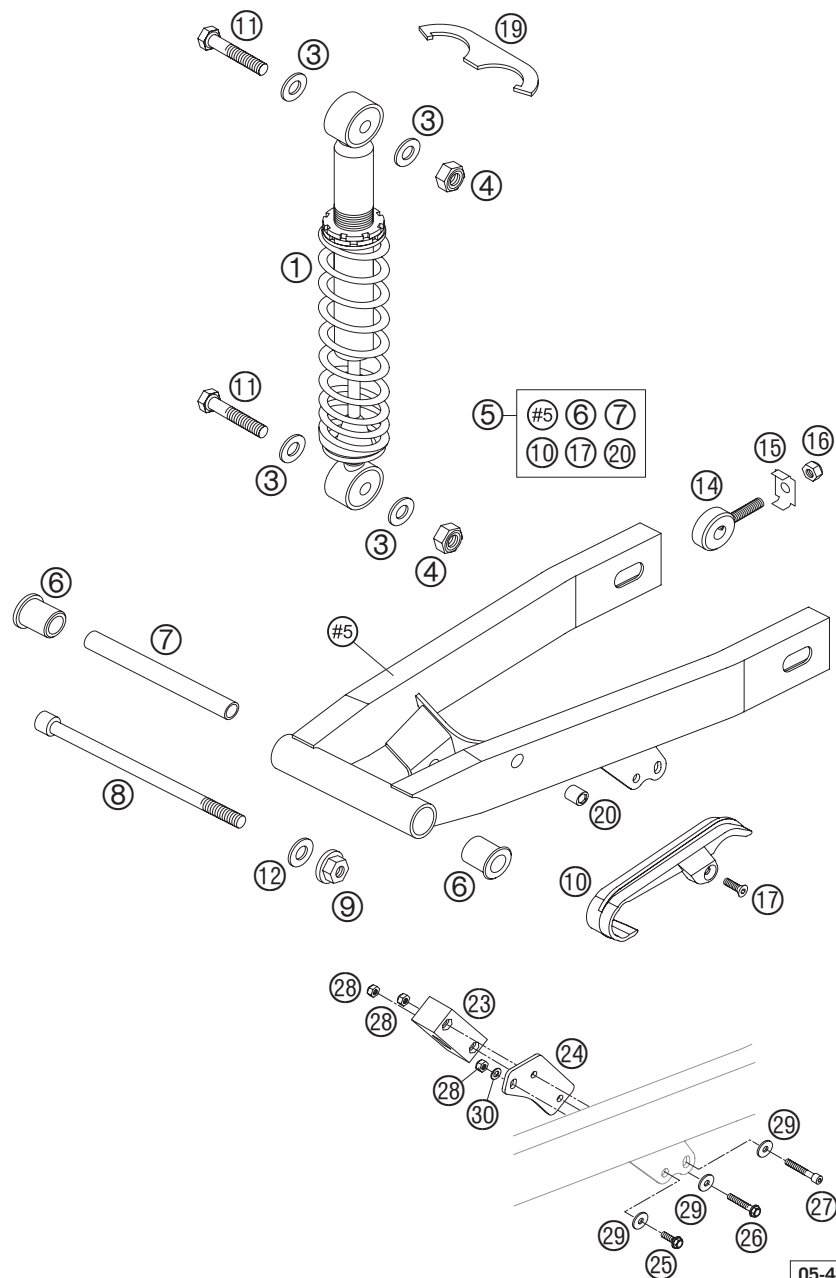

05-450.04.0

FIG	TEILNR/PARTNR	BEZEICHNUNG	DESCRIPTION	QTY
1*	451.04.010.700	MONOSHOCK ADV GS L=245MM 05	SHOCK ABSORB.ADV GS L=245MM 05	1
3	0125 100003	UNTERLEGSCHIBE DIN 125 A 10,5	WASHER DIN0125-A10,5	4
4	0982 100003	SS.MUTTER DIN0982-M10 HOCH	SELF LOCK.NUT DIN0982-M10 HIGH	2
5	451.04.030.044	SCHWINGE KPL. JUN. ADV.+LC 02	SWINGARM CPL. JUN. ADV.+LC 02	1
6	450.04.031.000	LAGERBÜCHSE L=30 MM	BUSHING BOX L=30 MM	2
7	450.04.039.000	DISTANZROHR 10X13X140 MM	SPACING TUBE 10X13X140 MM	1
8	451.03.014.000	SCHWINGARMBOLZEN M10X158,5 02	SWING ARM BOLT M10X158,5 02	1
9	490.09.082.000	STOVERFLANSCHMUTTER M10 FK8	SELF LOCKING NUT M10 FK8	1
10	451.04.066.000	KETTENGLEITSCH. VO. MINI 2002	CHAIN SLID. GUARD FRO. MINI 02	1
11	0931 100453	SK.SCHRAUBE DIN 931 M10X45	HH SCREW DIN0931-M10X45	2
12	310.04.001.100	SCHEIBE 10,5 X 21 X 3	WASHER 10,5 X 21 X 3	1
14	450.10.083.000	KETTENSANNER	CHAIN ADJUSTER	2
15	450.10.083.060	KETTENSANNERSTÜTZBLECH	SUPPORTING BRACKET	2
16	0985 080003	SS.MUTTER DIN0985-M 8	SELF LOCKING NUT DIN0985-M 8	2
17	0991 060203	SENKSCHRAUBE DIN7991 M6X20 8.8	FLAT H.SCREW DIN7991-M6X20 8.8	1
19	450.04.010.090	HAKENSCHLÜSSEL 50 SXR	HOOK WRENCH 50 SXR	1
20	550.03.139.900	BLINDNIETMUTTER M6 STAHL 4MM	BLIND RIVET THREAD M6 STE. 4MM	1
23	450.04.070.000	KETTENFÜHRUNG HINTEN	CHAIN GUIDE REAR	1
24	451.04.170.000	KETTENFÜHRUNGS BEF.BLECH 02	BRACKET FOR CHAIN GUARD 02	1
25	0015 050163	SK.BUNDSCHRAUBE M 5X16 SW=8	HH COLLAR SCREW M 5X16 WS=8	1
26	0015 050303	SK.BUNDSCHRAUBE M 5X30 SW=8	HH COLLAR SCREW M 5X30 WS=8	1
27	0912 050353	ISK.SCHRAUBE DIN0912-M 5X35	AH SCREW DIN912 M5X35	1
28	0985 050003	SS.MUTTER DIN 985 M5	SELF LOCKING NUT DIN0985-M 5	3
29	0021 050003	SCHEIBE DIN 9021 A 5,3	WASHER DIN9021-A 5,3	3
30	0125 050003	UNTERLEGSCHIBE DIN 125 A 5,3	WASHER DIN0125-A 5,3	1

05-450.04.0

* NEUTEIL / NEW PART X NACH BEDARF / AS REQUIRED

SCHWINGARM · FEDERBEIN » SWINGARM · MONOSHOCK

50 SENIOR ADV. / 2005

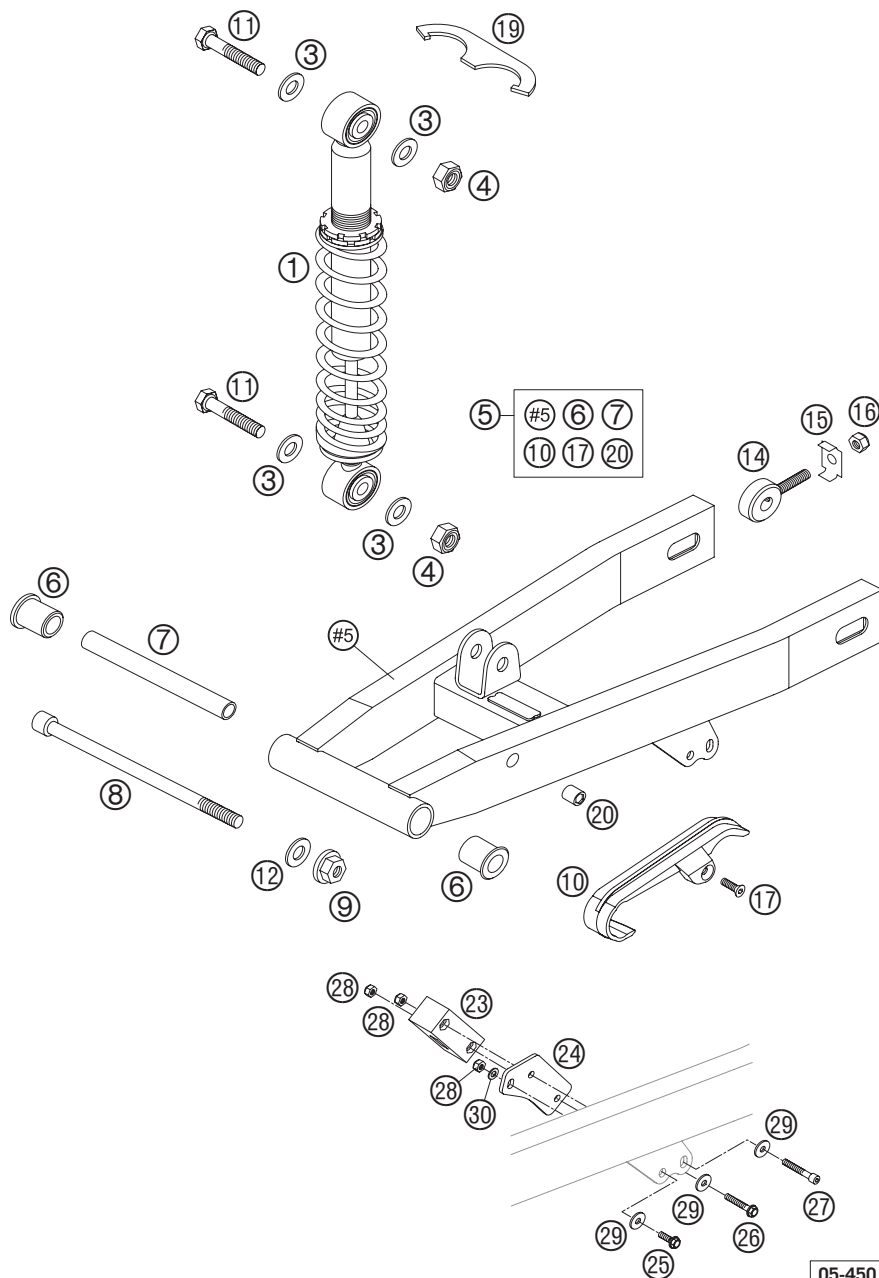

FIG	TEILNR/PARTNR	BEZEICHNUNG	DESCRIPTION	QTY
1	451.04.010.400	MONOSHOCK SX SEN. L=275MM 02	SHOCK ABSORBER SEN. L=275MM 02	1
3	0125 100003	UNTERLEGSCHIBE DIN 125 A 10,5	WASHER DIN0125-A10,5	4
4	0982 100003	SS.MUTTER DIN0982-M10 HOCH	SELF LOCK NUT DIN0982-M10 HIGH	2
5	451.04.030.144	SCHWINGE KPL. SEN. ADV.+LC 02	SWINGARM CPL. SEN. ADV.+LC 02	1
6	450.04.031.000	LAGERBÜCHSE L=30 MM	BUSHING BOX L=30 MM	2
7	450.04.039.000	DISTANZROHR 10X13X140 MM	SPACING TUBE 10X13X140 MM	1
8	451.03.014.000	SCHWINGARMBOLZEN M10X158,5 02	SWING ARM BOLT M10X158,5 02	1
9	490.09.082.000	STOVERFLANSCHMUTTER M10 FK8	SELF LOCKING NUT M10 FK8	1
10	451.04.066.000	KETTENGLEITSCH. VO. MINI 2002	CHAIN SLID. GUARD FRO. MINI 02	1
11	0931 100453	SK.SCHRAUBE DIN 931 M10X45	HH SCREW DIN0931-M10X45	2
12	310.04.001.100	SCHEIBE 10,5 X 21 X 3	WASHER 10,5 X 21 X 3	1
14	450.10.083.000	KETTENSPELLER	CHAIN ADJUSTER	2
15	450.10.083.060	KETTENSPELLERSTÜTZBLECH	SUPPORTING BRACKET	2
16	0985 080003	SS.MUTTER DIN0985-M 8	SELF LOCKING NUT DIN0985-M 8	2
17	0991 060203	SENKSCHRAUBE DIN7991 M6X20 8.8	FLAT H.SCREW DIN7991-M6X20 8.8	1
19	450.04.010.090	HAKENSCHLÜSSEL 50 SXR	HOOK WRENCH 50 SXR	1
20	550.03.139.900	BLINDNIETMUTTER M6 STAHL 4MM	BLIND RIVET THREAD M6 STE. 4MM	1
23	450.04.070.000	KETTENFÜHRUNG HINTEN	CHAIN GUIDE REAR	1
24	451.04.170.000	KETTENFÜHRUNGS BEF.BLECH 02	BRACKET FOR CHAIN GUARD 02	1
25	0015 050163	SK.BUNDSCHRAUBE M 5X16 SW=8	HH COLLAR SCREW M 5X16 WS=8	1
26	0015 050303	SK.BUNDSCHRAUBE M 5X30 SW=8	HH COLLAR SCREW M 5X30 WS=8	1
27	0912 050353	ISK.SCHRAUBE DIN0912-M 5X35	AH SCREW DIN912 M5X35	1
28	0985 050003	SS.MUTTER DIN 985 M5	SELF LOCKING NUT DIN0985-M 5	3
29	0021 050003	SCHEIBE DIN 9021 A 5,3	WASHER DIN9021-A 5,3	3
30	0125 050003	UNTERLEGSCHIBE DIN 125 A 5,3	WASHER DIN0125-A 5,3	1

05-450.04.1

05-450.04.1

* NEUTEIL / NEW PART X NACH BEDARF / AS REQUIRED

AUSPUFFANLAGE » EXHAUST SYSTEM

50 AC / 2005

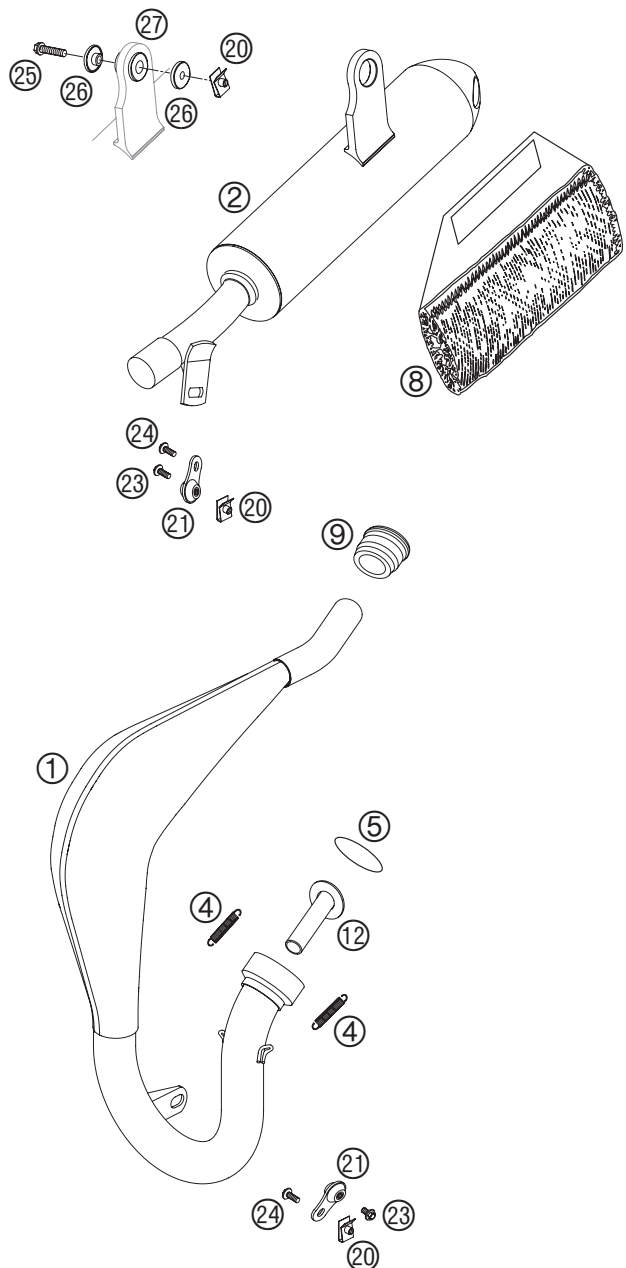

05-450.05.0

04-450.05.0

FIG	TEILNR/PARTNR	BEZEICHNUNG	DESCRIPTION	QTY
1	451.05.008.000	AUSPUFF 50 ADVENTURE 2002	EXHAUST PIPE 50 ADVENTURE 2002	1
2	451.05.079.100	ENDDÄMPFER SX JUNIOR MINI ADV.	SILENCER SX JUNIOR 2002 MINI ADV.	1
2	451.05.079.000	ENDDÄMPFER SX SENIOR SENIOR ADV.	SILENCER SX SENIOR 2001 SENIOR ADV.	1
4	503.05.016.000	ZUGFEDER L=55MM ÖSEN BEWEGLICH	TEN.SPRING L=55MM EY.MOVEABLE	2
5	0770 320030	O-RING 32,00X3,00 VITON	O-RING 32,00X3,00 VITON	1
8	451.05.079.056	DÄMMSTOFF FORMTEIL 50 110 GRAMM GESAMTGEWICHT	ROCKWOOL PREFOMED 50 2002 110 GRAMM TOTAL WEIGHT	1
9	451.05.057.000	AUSPUFFGUMMI MINI 2002	EXHAUST RUBBER MINI 2002	1
12	451.05.083.000	AUSPUFFDROSSEL KPL. MINI MINI ADV.	EXHAUST THROTTLE CPL. MINI 02 MINI ADV.	1
20	546.03.048.100	MEHRBEREICHBLECHMUTTER M6	RANGE CHANGE METAL NUT M6	3
21	503.05.012.000	SCHWINGELEMEN FÜR AUSPUFF	SWINGELEMEN FOR EXHAUST PIPE	2
23	0015 060123	SK.BUNDSCHRAUBE M 6X12 SW=8	HH COLLAR SCREW M 6X12 WS=8	2
24	0014 060153	SK.BUNDSCHRAUBE M 6X15 SW=8	HH COLLAR SCREW M 6X15 WS=8	2
25	0015 060303	SK.BUNDSCHRAUBE M 6X30 SW=8	HH COLLAR SCREW M 6X30 WS=8	1
26	546.05.069.000	BÜCHSE 7,5X12X28X7,8 '96	BUSHING 7,5X12X28X7,8 '96	2
27	546.05.068.000	DÄMPFUNGSSELEMAN SCHWARZ	EXHAUST BRACKET RUBBER BLACK	1

* NEUTEIL / NEW PART X NACH BEDARF / AS REQUIRED

TANK · SITZBANK · VERKLEIDUNG » *TANK · SEAT · COVER*

50 AC / 2005

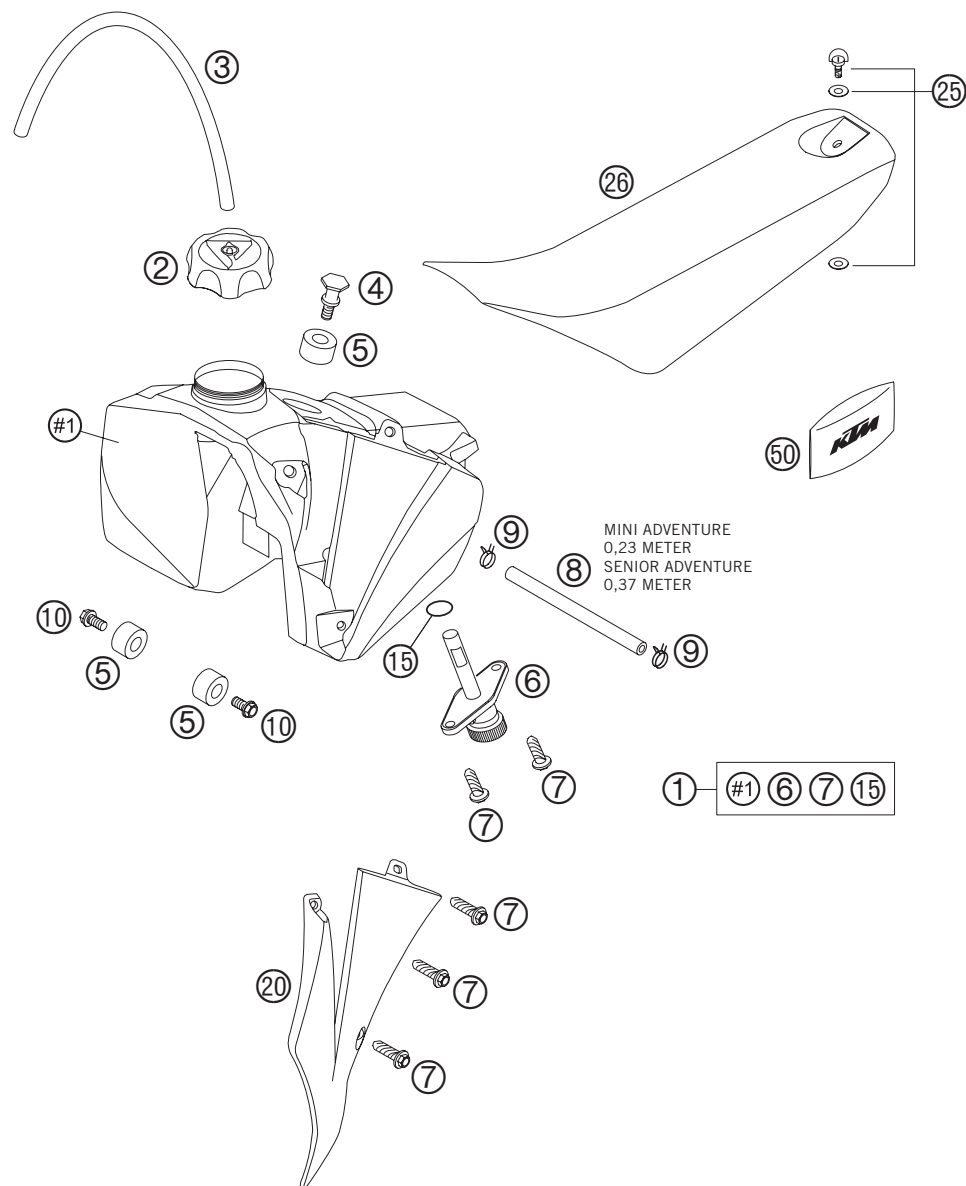

05-450.07.0

FIG	TEILNR/PARTNR	BEZEICHNUNG	DESCRIPTION	QTY
1	451.07.113.000/04	BENZINTANK 50 MINI AC 2003	FUEL TANK 50 MINI AC 2003	1
2	490.07.008.044	TANKVERSCHLUSS KPL. KLEIN	FILLER CAP CPL. SMALL	1
3	310.07.107.001	PVC-SCHLAUCH 6X9 MM PER METER	PVC-HOSE 6X9 MM PER METRE	0,32
4	451.07.011.000	SITZBANKBEF.SCHRAUBE 50 2001	TANK SCREW MINI 50 2001	1
5	503.07.014.000	TANKROLLE 12X26X12 '98	TANK ROLLER 12X26X12 '98	3
6	585.07.003.000	BENZINHAHN KPL.KLEIN RALLYE'96	FUEL COCK CPL. SMALL RALLYE'96	1
7	0017 060203	SONDERSCHRAUBE T60 6X20 SW=6	SPECIAL SCREW T60 6X20 WS=6	8
8	583.07.016.001	BENZINSCHL. VITON 6X1,5 PER/M	FUEL HOSE VITON 6X1,5 PER/M	X
9	450.31.005.000	YDNAC-KLAMMER BENZINSCHL.(8MM)	YDNAC-CLAMP FUEL HOSE (8MM)	2
10	0015 060123	SK.BUNDSCHRAUBE M 6X12 SW=8	HH COLLAR SCREW M 6X12 WS=8	2
15	550.07.006.200	O-RING 11X1,8 NBR 70	O-RING 11X1,8 NBR 70	1
20	451.08.050.000/04	SPOILER LINKS SX JUN/SEN 2001	SPOILER LEFT SX JUN/SEN 2001	1
20	451.08.051.000/04	SPOILER RECHTS SX JUN/SEN 2001	SPOILER RIGHT SX JUN/SEN 2001	1
25	450.07.040.051	SCHNELLVERSCHLUSS KPL.50SXR'97	QUICK RELEASE CPL. 50 SXR '97	1
26*	451.07.040.500	SITZBANK 50 AC+LC 2005 SENIOR ADVENTURE	SEAT 50 AC+LC 2005 SENIOR ADVENTURE	1
26*	451.07.040.600	SITZBANK MINI ADV. NIEDER 2005 MINI ADVENTURE	SEAT MINI ADV. LOW 2005 MINI ADVENTURE	1
50	450.29.099.000	BORDWERKZEUG 50 MINI, 60/65 SX	TOOL SET 50 MINI, 60/65 SX	1

05-450.07.0

* NEUTEIL / NEW PART X NACH BEDARF / AS REQUIRED

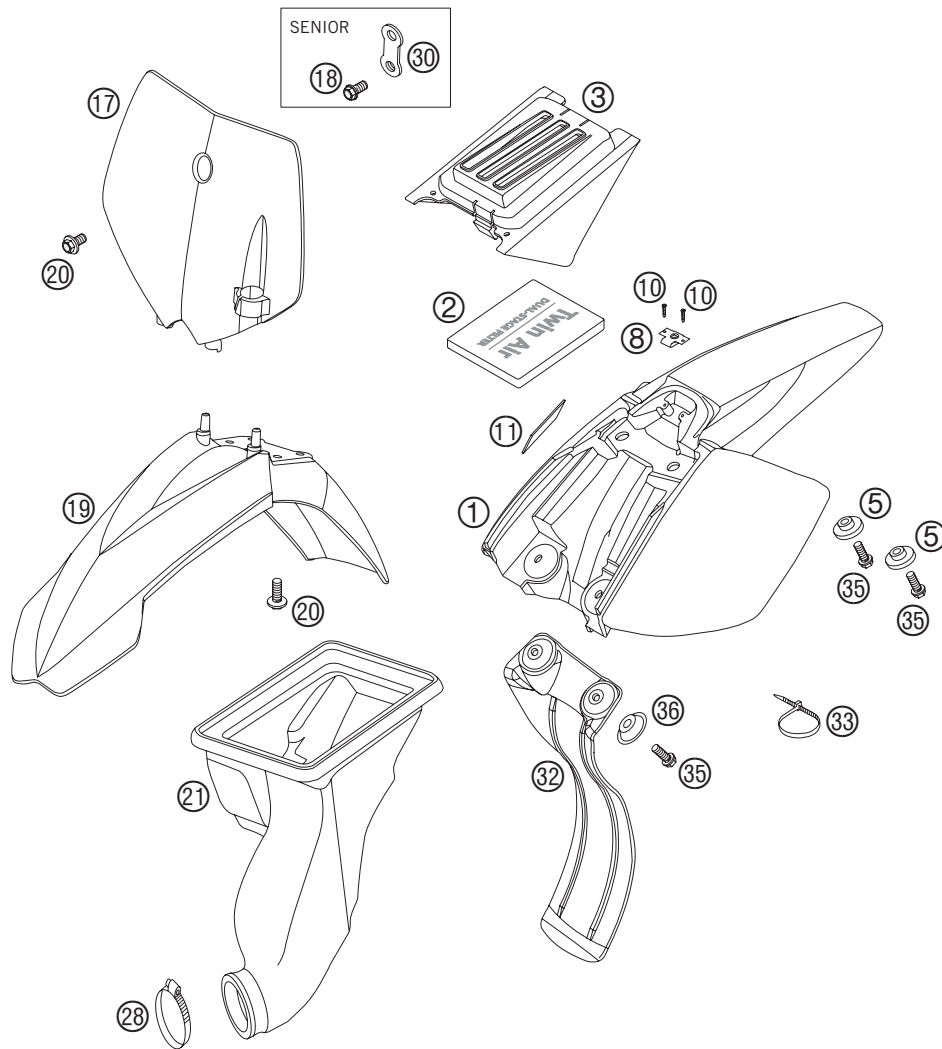

05-450.08.0

05-450.08.0

FIG	TEILNR/PARTNR	BEZEICHNUNG	DESCRIPTION	QTY
1	451.08.013.000/04	HECKTEIL 50 MINI ORANGE 2003	REAR PART 50 MINI ORANGE 2003	1
2	451.06.015.000	LUFTFILTER 134X96X15MM 01	AIR FILTER 134X96X15MM 01	1
3	451.06.012.000	FILTERDECKEL JUN/SEN 2001	FILTER COVER JUN/SEN 2001	1
5	451.08.013.050	BÜCHSE F. HECK SX JUN/SEN 2001	BUSH F.REAR P. SX JUN/SEN 2001	2
8	450.07.040.050	WIDERLAGER SCHNELLVERSCHLUSS	QUICK RELEASE LATCHPLATE	1
10	0981 350163	LI.BLECHSCHR. DIN7981- 3,5X16	SHEET MET.SCR.DIN7981- 3,5X16	2
11*	590.03.001.099	METAMOLL 90X45X3MM 03	METAMOLL 90X45X3MM 03	1
17	451.08.007.000/04	STARTNUMMERTAFEL SX JUN/SEN 01	NUMBER PLATE SX JUN/SEN 2001	1
18	0015 060103	SK.BUNDSCHRAUBE M 6X10 SW=8	HH COLLAR SCREW M 6X10 WS=8	1
19	451.08.010.000/04	KOTFLÜGEL VORNE SX JUN/SEN 01	FENDER FRONT SX JUN/SEN 2001	1
20	0014 060103	SK.BUNDSCHRAUBE M 6X10 SW=8	HH COLLAR SCREW M 6X10 WS=8	5
21	451.06.026.000	VERGASERMANSCHETTE SXR JUN. 02 MINI ADV.	CARBUR.CONNEC.BOOT SXR JUN. 02 MINI ADV.	1
21	451.06.026.100	VERGASERMANSCHETTE SXR SEN. 01 SENIOR ADV.	CARBUR.CONNEC.BOOT SXR SEN. 01 SENIOR ADV.	1
28	543.05.058.000	SCHLAUCHBINDER 30-45 SGT	HOSE CLAMP 30-45 SGT	1
30	451.08.007.050	HALTEBLECH F.STARTNUMMERTAFEL	BRACKET FOR NUMBER PLATE	1
32	451.06.010.000	SPRITZSCHUTZ JUNIOR 2002 MINI ADV.	SPLASH PROTECTOR JUNIOR 2002 MINI ADV.	1
32	451.06.010.100	SPRITZSCHUTZ SENIOR 2001 SENIOR ADV.	SPLASH PROTECTOR SENIOR 2001 SENIOR ADV.	1
33	440.11.076.305	KABELBAND 300/4,8MM SCHWARZ	CABLE TIE 300/4,8MM BLACK	2
35	0015 060163	SK.BUNDSCHRAUBE M 6X16 SW=8	HH COLLAR SCREW M 6X16 WS=8	4
36	722.10.079.000	STÜTZSCHALE	BUCKET	2

* NEUTEIL / NEW PART X NACH BEDARF / AS REQUIRED

FIG	TEILNR/PARTNR	BEZEICHNUNG	DESCRIPTION	QTY
1*	451.08.199.400	DEKORSATZ KPL. 50 MINI ADV. 05	DECAL SET CPL. 50 MINI ADV. 05	1
2*	451.08.199.500	DEKORSATZ KPL. 50 SEN. ADV. 05	DECAL SET CPL. 50 SEN. ADV. 05	1

①

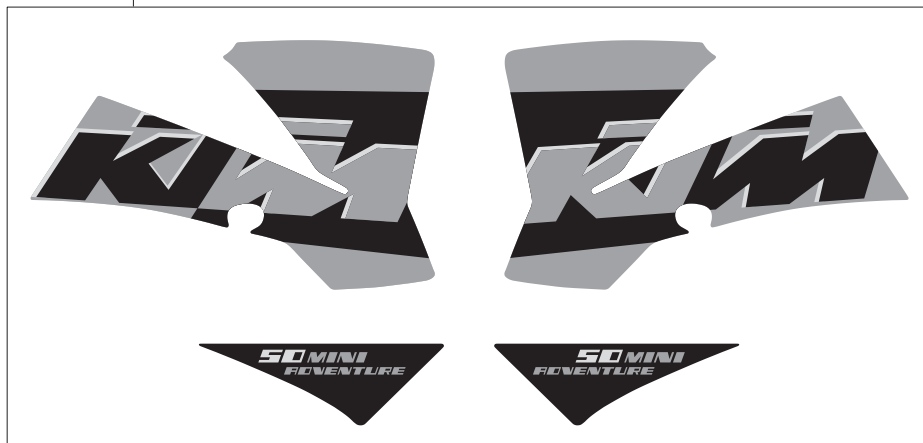

②

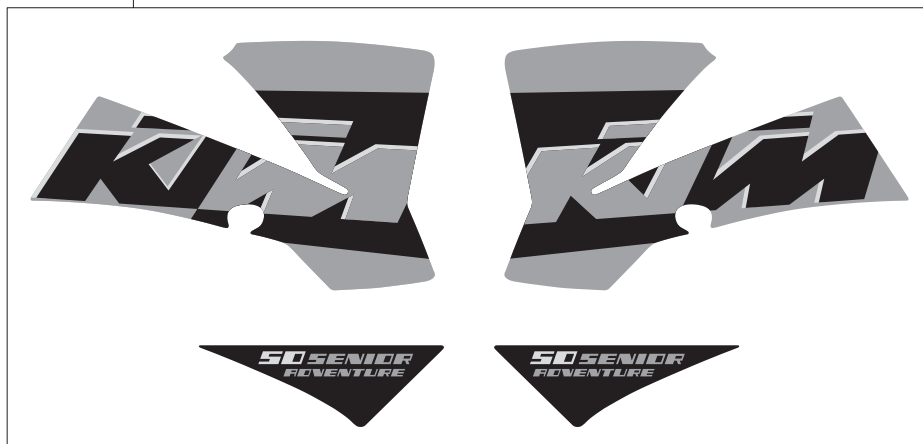

05-450.08.1

05-450.08.1

* NEUTEIL / NEW PART X NACH BEDARF / AS REQUIRED

VORDERRAD » FRONT WHEEL

50 MINI ADV. / 2005

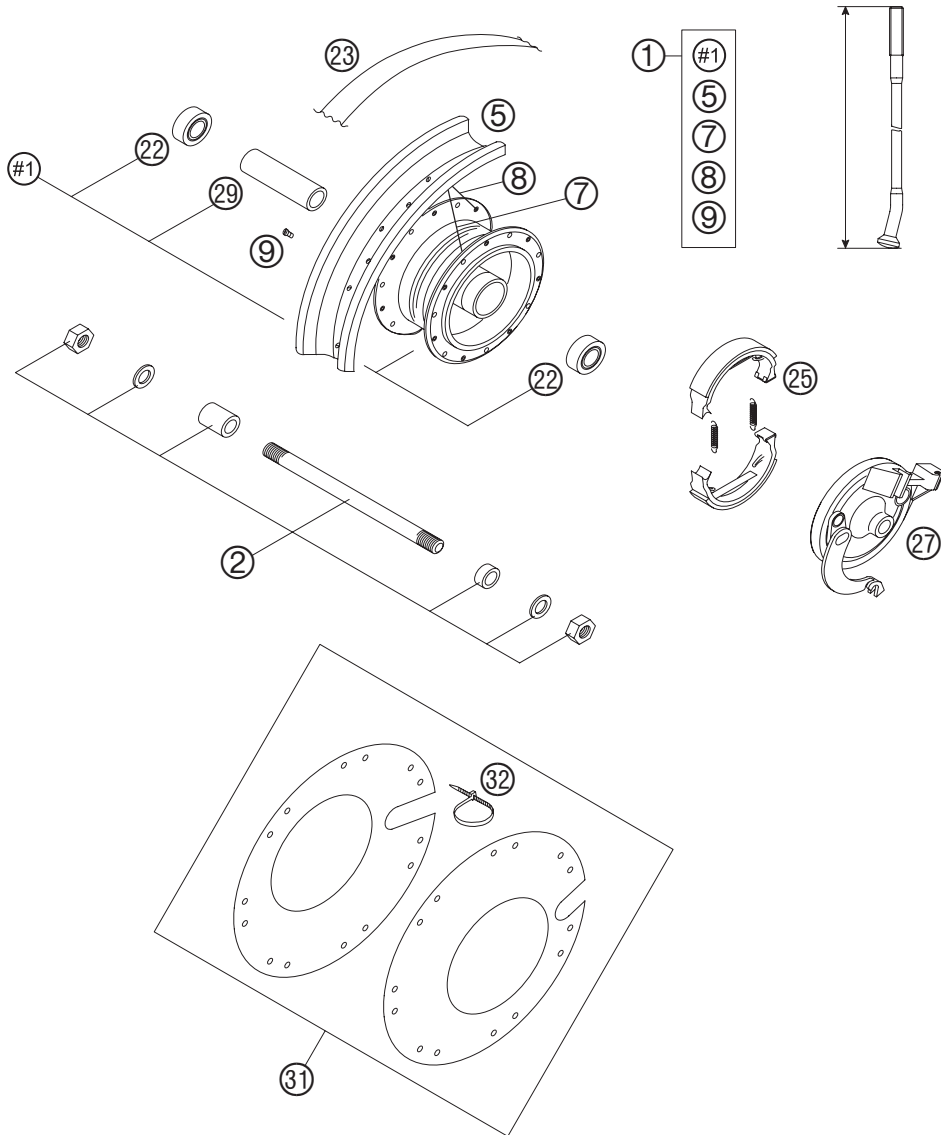

FIG	TEILNR/PARTNR	BEZEICHNUNG	DESCRIPTION	QTY
1	451.09.001.344	VORDERRAD-ET KPL.1,5X10" STAHL	REAR WHEEL-SP CPL.1,5X10"STEEL	1
2	450.09.081.000	STECKACHSE VORNE KPL. L=207MM	AXLE FRONT CPL. L=202MM	1
5	450.09.070.000	FELGE 1,50X10" STAHL	RIM 1,50X10" STEEL	2
7	450.09.071.200	SPEICHE 3X70X3,5MM-95°	SPOKE 3X70X3,5MM-95°	14
8	450.09.171.200	SPEICHE 3X69X4,5MM-80°	SPOKE 3X69X4,5MM-80°	14
9	451.09.072.000	SPEICHENNIPPEL 3MM	SPOKE NIPPLE 3MM	28
22	0625 060016	RILLENKUGELLAGER 6001.2RSR C3	GROOV.BALL BEAR. 6001.2RSR C3	2
23*	450.09.073.000	FELGENBAND 10" 22MM	RIM BAND 10" 22MM	1
25	450.09.035.000	BREMSBACKEN-GARN.	BRAKE SHOES GARN.	1
27	450.09.030.000	TRAGPLATTE KPL. VORNE	SUPPORTING PLATE CPL. FRONT	1
29	450.09.011.000	DISTANZROHR VORNE	DISTANCE TUBE FRONT	1
31	451.10.092.000	RADABDECKUNG KPL. 50SX LC 03	WHEEL COVER CPL. 50SX LC 03	1
32	440.11.076.305	KABELBAND 300/4,8MM SCHWARZ	CABLE TIE 300/4,8MM BLACK	7

05-450.09.0

05-450.09.0

* NEUTEIL / NEW PART X NACH BEDARF / AS REQUIRED

VORDERRAD » FRONT WHEEL

50 SENIOR ADV. / 2005

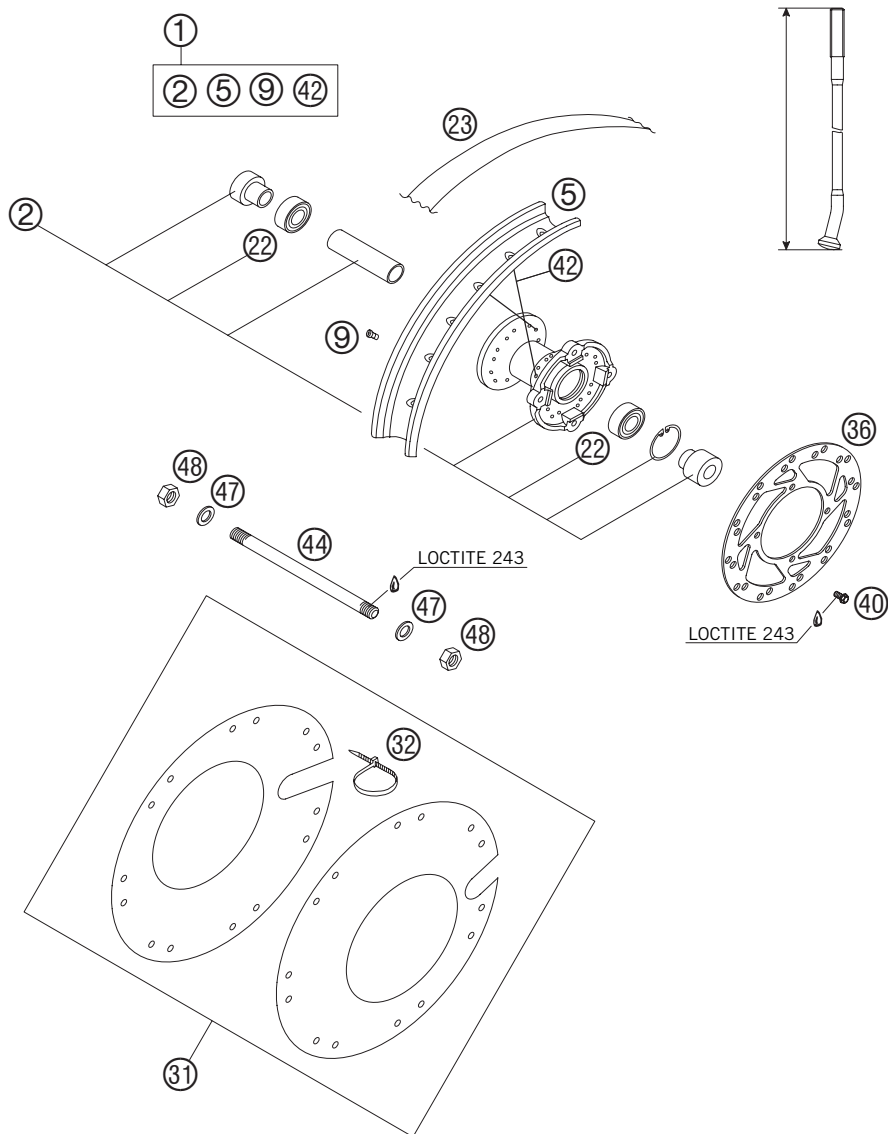

FIG	TEILNR/PARTNR	BEZEICHNUNG	DESCRIPTION	QTY
1	451.09.001.244	VORDERRAD-ET KPL. 1,5X12" ALU	FRONT WHEEL-SP CPL.1,5X12" ALU	1
2	451.09.010.044	VORDERRADNABE KPL. 2002	FRONT WHEEL HUB CPL. 2002	1
5	451.09.070.000	FELGE VORNE 1,5X12" ALUMINIUM	RIM FRONT 1,5X12" ALUMINIUM	1
9	451.09.072.000	SPEICHENNIPPEL 3MM	SPOKE NIPPLE 3MM	28
22	0625 062027	RILLENKUGELLAGER 6202 2RS1 C3	BALL BEARING 6202 2RS1 C3	2
23*	451.09.073.100	FELGENBAND 12"	RIM BAND 12"	1
31	451.10.092.000	RADABDECKUNG KPL. 50SX LC 03	WHEEL COVER CPL. 50SX LC 03	1
32	440.11.076.305	KABELBAND 300/4,8MM SCHWARZ	CABLE TIE 300/4,8MM BLACK	7
36	451.09.060.000	BREMSSCHEIBE VORNE JUN/SEN 02	BRAKE DISC FRONT JUN/SEN 02	1
40	590.09.062.013	SONDERSCHRAUBE M6X13 SW=8 10.9	SPECIAL SCREW M6X13 WS=8 10.9	4
42	451.09.071.129	SPEICHE 3X124X5MM-110° 02	SPOKE 3X124X5MM-110° 02	28
44	460.10.085.000	STECKACHSE 207MM M12X1	AXLE 207MM M12X1	1
47	0125 120003	UNTERLEGSCHLEIBE DIN 125 A 13	FLAT WASHER DIN0125-A13	2
48	0934 120103	SK.MUTTER DIN 934 M12X1	HEXAGON NUT DIN0934-M12X1	2

05-450.09.1

05-450.09.1

* NEUTEIL / NEW PART X NACH BEDARF / AS REQUIRED

BREMSZANGE VORNE » BRAKE CALIPER FRONT

50 SENIOR ADV. / 2005

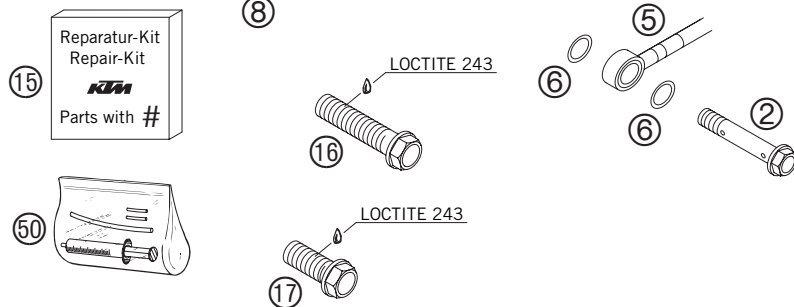
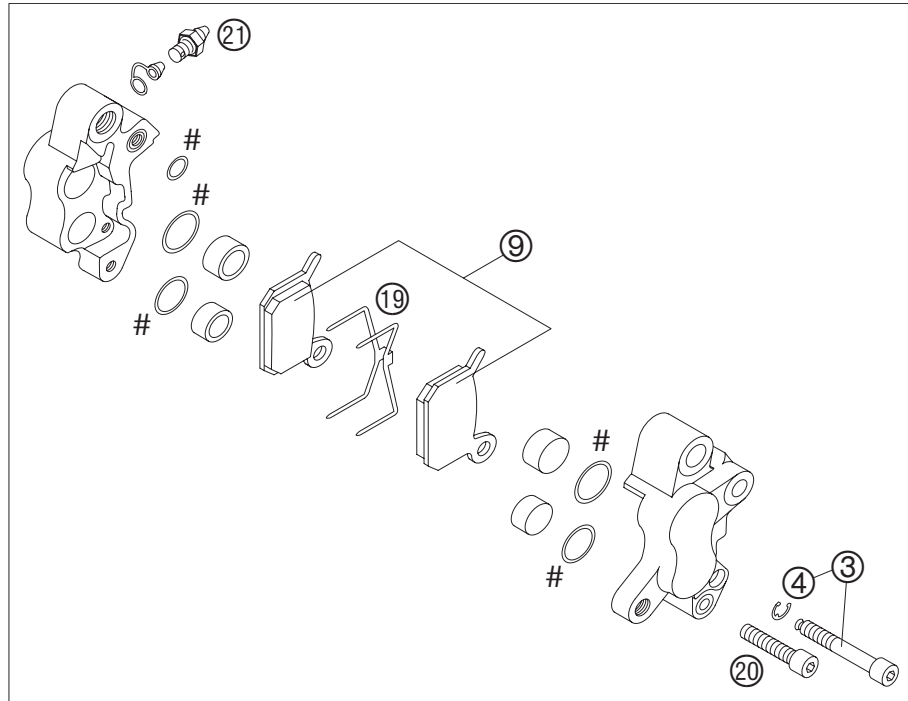

FIG	TEILNR/PARTNR	BEZEICHNUNG	DESCRIPTION	QTY
2	451.13.025.000	HOHLSCHRAUBE M6X34 LC 50 2002	HOLLOW SCREW M6X34 50 LC 2002	1
3	451.13.125.000	ISK.SCHRAUBE + S-RING 50 LC 02	AH SCREW+CIRCLIP LC 50 02	1
4	0799 025000	SICH.SCHEIBE DIN6799-RS 2,5	TAB WASHER DIN6799 RS2,5	1
5	451.13.012.100	BREMSSCHL.VO. SX SEN. LC 2002	BRAKE HOSE FR. SX SEN. LC 2002	1
6	0770 080019	O-RING 8,00X1,00 EPDM	O-RING 8,00X1,00 EPDM	2
8	451.13.015.000	BREMSZANGE KPL. VORNE 50 LC 02	BRAKE CALIPER CPL.FR. 50 LC 02	1
9	451.13.030.000	GARN. BREMSKLÖTZE 50 LC 2002	BRAKE PAD SET 50 LC 2002	1
15	451.13.019.000	REP.SATZ DICHRING 50LC 2002	REP.KIT SEAL RING 50LC 2002	1
16	0015 080350	SK.BUNDSCHRAUBE M8X35 SW=10 SS	HH COLLAR SCREW M8X35 W.L.WS10	1
17	0015 080203	SK.BUNDSCHRAUBE M 8X20 SW=10	HH COLLAR SCREW M 8X20 WS=10	1
19	451.13.018.000	HALTEFEDER 50 LC	RETAINING SPRING 50 LC	1
20	0912 050203	ISK.SCHRAUBE DIN 912 M5X20	AH SCREW DIN0912-M 5X20	1
21	451.13.020.000	ENTLÜFTUNGSSCHRAUBE 50 2002	BREATHER SCREW 50 2002	1
50*	451.19.050.000	ENTLÜFTUNGSSPRITZEN-SET 50-65	BLEEDER INJECTION-SET 50-65	1

05-450.13.1

05-450.13.1

* NEUTEIL / NEW PART X NACH BEDARF / AS REQUIRED

HINTERRAD » REAR WHEEL

50 MINI ADV. / 2005

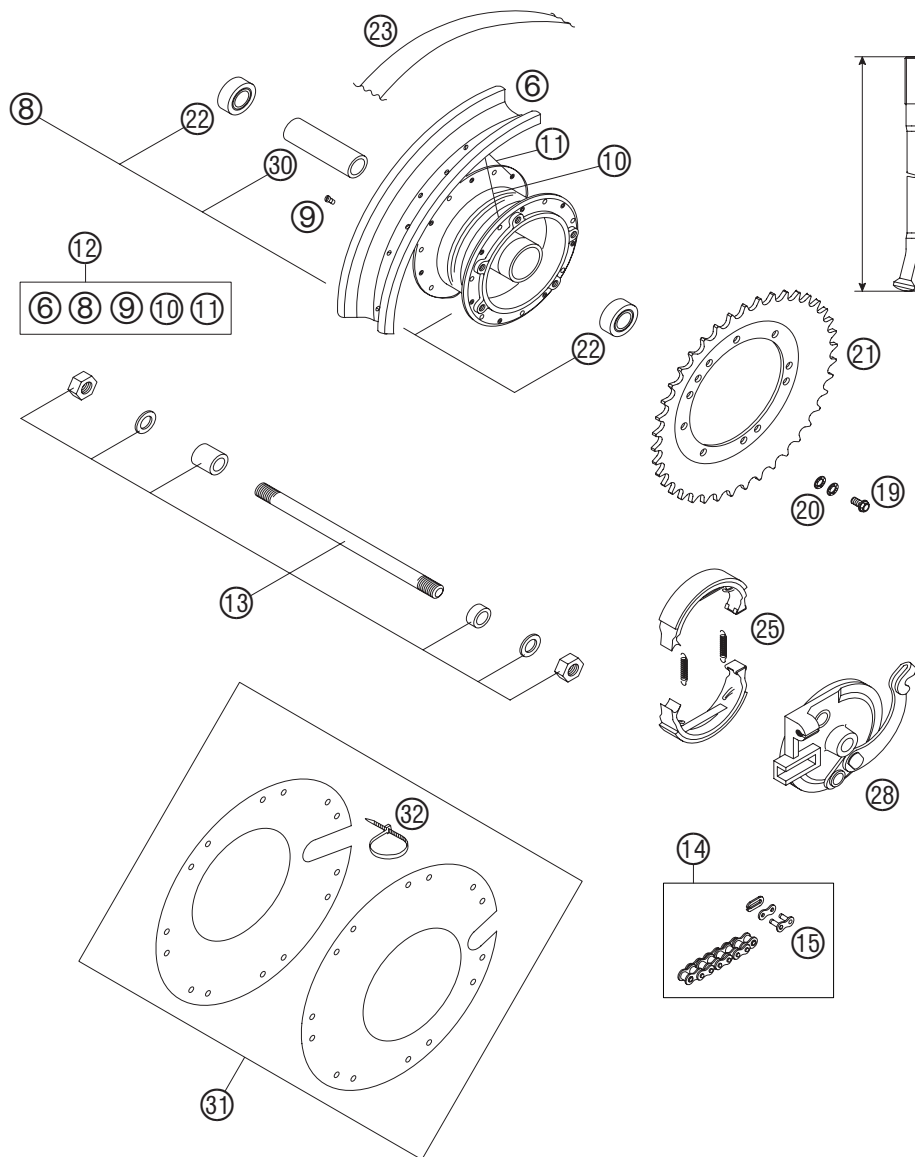

FIG	TEILNR/PARTNR	BEZEICHNUNG	DESCRIPTION	QTY
6	450.09.070.000	FELGE 1,50X10" STAHL	RIM 1,50X10" STEEL	1
8	451.10.010.044	HINTERRADNABE KPL. 2003	REAR WHEEL HUB CPL. 2003	1
9	451.09.072.000	SPEICHENNIPPEL 3MM	SPOKE NIPPLE 3MM	28
10	450.10.071.200	SPEICHE 3X72X4,2MM-100°	SPOKE 3X72X4,2MM-100°	14
11	450.10.171.200	SPEICHE 3X72X5MM-65°	SPOKE 3X72X5MM-65°	14
12	451.10.001.244	HINTERRAD-ET KPL.1,5X10" STAHL	REAR WHEEL-SP CPL.1,5X10"STEEL	1
13	450.10.081.000	STECKACHSE HINTEN KPL. L=210MM	AXLE REAR CPL. L=210MM	1
14	451.10.165.104	KETTE 1/2X3/16" MIT K. SCHLOSS 104 ROLLEN	CHAIN 1/2X3/16" WITH M.LINK 104 ROLLS	1
15	451.10.166.000	KETTENSCHLOSS 1/2X3/16"	MASTER LINK 1/2X3/16"	1
19	0015 060163	SK.BUNDSCHRAUBE M 6X16 SW=8	HH COLLAR SCREW M 6X16 WS=8	5
20	502.33.041.000	NORDLOCKSCHLEIBEN M6 (PAAR) DAC	PAIR OF WASHERS M 6 NORDLOCK	5
21	450.10.051.044	KETTENRAD 44-Z	SPROCKET 44-T	X
21	450.10.051.045	KETTENRAD 45-Z	SPROCKET 45-T	X
21	450.10.051.046	KETTENRAD 46-Z	SPROCKET 46-T	X
21	450.10.051.048	KETTENRAD 48-Z	SPROCKET 48-T	1
22	0625 060016	RILLENKUGELLAGER 6001.2RSR C3	GROOV.BALL BEAR. 6001.2RSR C3	2
23*	450.09.073.000	FELGENBAND 10" 22MM	RIM BAND 10" 22MM	1
25	450.09.035.000	BREMSBACKEN-GARN.	BRAKE SHOES GARN.	1
28	450.10.030.000	TRAGPLATTE KPL. HINTEN	SUPPORTING PLATE CPL. REAR	1
30	450.10.011.000	DISTANZROHR HINTEN	DISTANCE TUBE REAR	1
31	451.10.092.000	RADABDECKUNG KPL. 50SX LC 03	WHEEL COVER CPL. 50SX LC 03	1
32	440.11.076.305	KABELBAND 300/4,8MM SCHWARZ	CABLE TIE 300/4,8MM BLACK	7

05-450.10.0

05-450.10.0

* NEUTEIL / NEW PART X NACH BEDARF / AS REQUIRED

HINTERRAD » REAR WHEEL

50 SENIOR ADV. / 2005

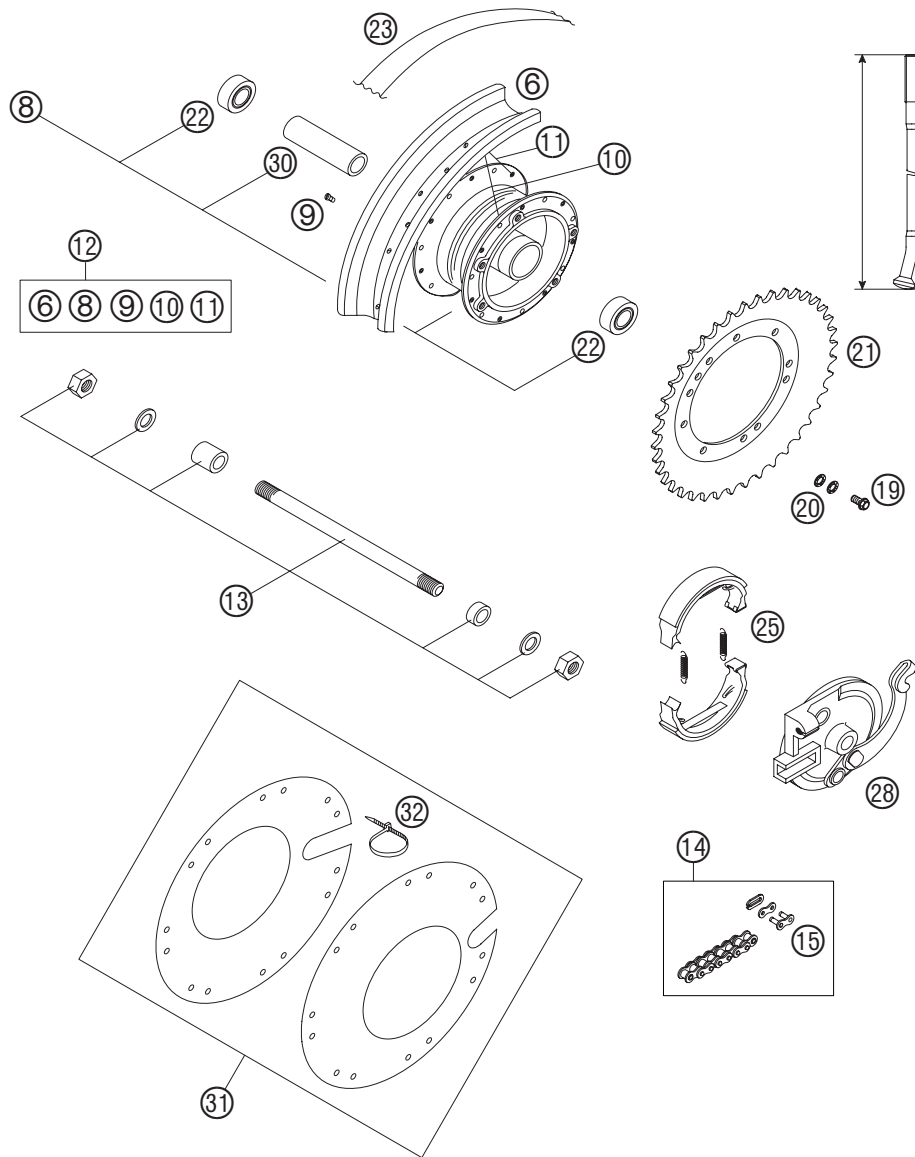

FIG	TEILNR/PARTNR	BEZEICHNUNG	DESCRIPTION	QTY
6	451.10.070.100	FELGE HINTEN 1,6X10" ALU	RIM REAR 1,6X10" ALU	1
8	451.10.010.244	HINTERRADNABE KPL. 2004	REAR WHEEL HUB CPL. 2004	1
9	451.09.072.100	SPEICHENNIPPEL M 4	SPOKE NIPPLE M 4	28
10	451.10.071.072	SPEICHE M3,97X72X70° 04	SPOKE M3,97X72X70° 04	14
11	451.10.171.072	SPEICHE M3,97X72X115° 04	SPOKE M3,97X72X115° 04	14
12	451.10.001.444	HINTERRAD-ET KPL. 1,60X10" ALU	REAR WHEEL-SP CPL.1,60X10" ALU	1
13	450.10.081.000	STECKACHSE HINTEN KPL. L=210MM	AXLE REAR CPL. L=210MM	1
14	451.10.165.104	KETTE 1/2X3/16" MIT K. SCHLOSS 104 ROLLEN	CHAIN 1/2X3/16" WITH M.LINK 104 ROLLS	1
15	451.10.166.000	KETTENSCHLOSS 1/2X3/16"	MASTER LINK 1/2X3/16"	1
19	0015 060163	SK.BUNDSCHRAUBE M 6X16 SW=8	HH COLLAR SCREW M 6X16 WS=8	5
20	502.33.041.000	NORDLOCKSCHLEIBEN M6 (PAAR) DAC	PAIR OF WASHERS M 6 NORDLOCK	5
21	450.10.051.044	KETTENRAD 44-Z	SPROCKET 44-T	X
21	450.10.051.045	KETTENRAD 45-Z	SPROCKET 45-T	X
21	450.10.051.046	KETTENRAD 46-Z	SPROCKET 46-T	X
21	450.10.051.048	KETTENRAD 48-Z	SPROCKET 48-T	1
22	0625 060016	RILLENKUGELLAGER 6001.2RSR C3	GROOV.BALL BEAR. 6001.2RSR C3	2
23*	450.09.073.000	FELGENBAND 10" 22MM	RIM BAND 10" 22MM	1
25	450.09.035.000	BREMSBACKEN-GARN.	BRAKE SHOES GARN.	1
28	450.10.030.000	TRAGPLATTE KPL. HINTEN	SUPPORTING PLATE CPL. REAR	1
30	450.10.011.000	DISTANZROHR HINTEN	DISTANCE TUBE REAR	1
31	451.10.092.000	RADABDECKUNG KPL. 50SX LC 03	WHEEL COVER CPL. 50SX LC 03	1
32	440.11.076.305	KABELBAND 300/4,8MM SCHWARZ	CABLE TIE 300/4,8MM BLACK	7

05-450.10.0

05-450.10.1

* NEUTEIL / NEW PART X NACH BEDARF / AS REQUIRED

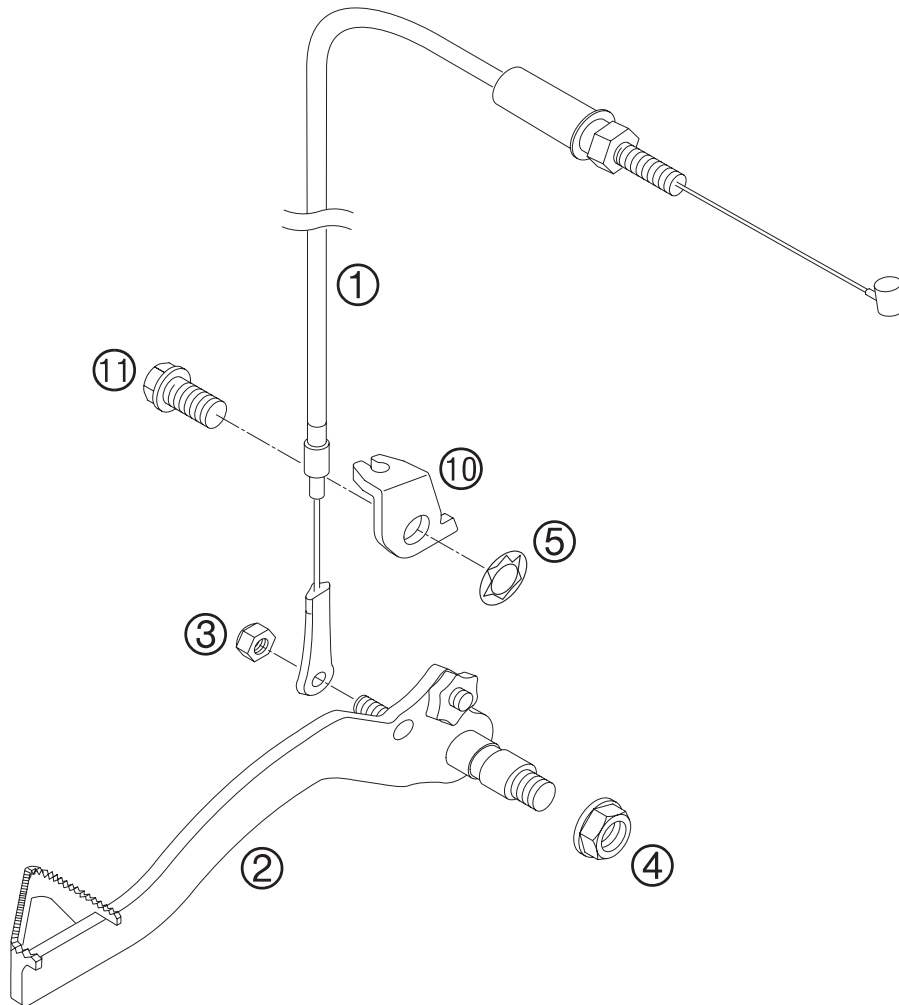
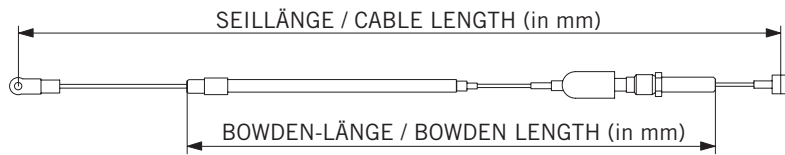

FIG	TEILNR/PARTNR	BEZEICHNUNG	DESCRIPTION	QTY
1	451.13.070.200	FUSSBREMSSEIL HINTEN 810/660 SENIOR ADV.	FOOT BRAKE CABLE REAR 810/660 SENIOR ADV.	1
1	451.13.070.300	FUSSBREMSSEIL HINTEN 720/570 MINI ADV.	FOOT BRAKE CABLE REAR 720/570 MINI ADV.	1
2	451.13.050.044	FUSSBREMSHEBEL KPL. 2001	FOOT BRAKE LEVER CPL. 2001	1
3	0985 050003	SS.MUTTER DIN 985 M5	SELF LOCKING NUT DIN0985-M 5	1
4	543.10.086.200	STOVER-FLANSCHMUTTER M8 10.9	SELF LOCKING NUT M8 10.9	1
5	0797 080003	ZAHNSCHEIBE DIN6797-J 8,4	TOOTHLOCK WASHER DIN6797-J 8,4	1
10	451.13.052.000	BREMSWIDERLAGER MINI 2001	BRAKE THRUST BEARING MINI 2001	1
11	0015 080163	SK.BUNDSCHRAUBE M 8X16 SW=10	HH COLLAR SCREW M 8X16 WS=10	1

05-450.12.0

04-450.12.0

* NEUTEIL / NEW PART X NACH BEDARF / AS REQUIRED

MOTORGEHÄUSE » ENGINE CASE

50 AC / 2005

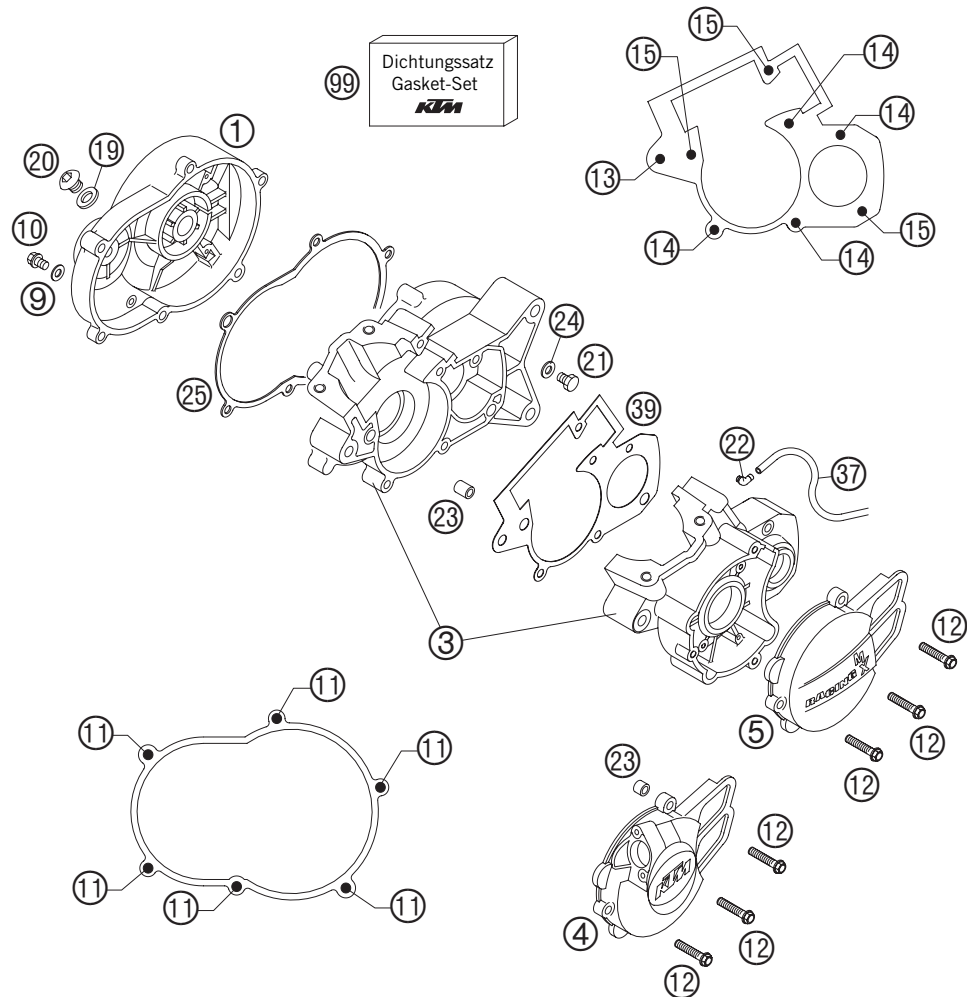

FIG	TEILNR/PARTNR	BEZEICHNUNG	DESCRIPTION	QTY
1	451.30.001.100	KUPPLUNGSDECKEL 50 2004	CLUTCH COVER 50 2004	1
3	451.30.000.044	MOTORGEHÄUSE 50CCM LC 2001	ENGINE CASE 50CCM LC 2001	1
4	451.30.502.100	ZÜNDUNGSDECKEL 50 GS 2002 MINI ADV.	IGNITION COVER 50 GS 2002 MINI ADV.	1
5	451.30.502.000	ZÜNDUNGSDECKEL 50 AC 2002 SENIOR ADV.	IGNITION COVER 50 AC 2002 SENIOR ADV.	1
9	0603 061001	CU-DICHRING DIN7603-6X10X1	CU-SEAL RING DIN7603-6X10X1	1
10	0015 060103	SK.BUNDSCHRAUBE M 6X10 SW=8	HH COLLAR SCREW M 6X10 WS=8	1
11	0015 060253	SK.BUNDSCHRAUBE M 6X25 SW=8	HH COLLAR SCREW M 6X25 WS=8	6
12	0015 060303	SK.BUNDSCHRAUBE M 6X30 SW=8	HH COLLAR SCREW M 6X30 WS=8	3
13	0015 080603	SK.BUNDSCHRAUBE M 8X60 SW=10	HH COLLAR SCREW M 8X60 WS=10	1
14	0912 060353	ISK.SCHRAUBE DIN 912 M6X35	AH SCREW DIN0912-M 6X35	4
15	0912 060404	ISK.SCHRAUBE DIN0912-M 6X40 A2	AH SCREW DIN0912-M 6X40 A2	3
19	451.30.019.000	DICHTUNG F. ÖLEINFÜLLSCHRAUBE	GASKET FOR OIL PLUG	1
20	451.30.020.000	ÖLEINFÜLLSCHRAUBE 50 LC 2001	OIL PLUG 50 LC 2001	1
21*	460.30.021.100	ÖLABLASSSCHRAUBE M10 SW=13	OIL DRAIN PLUG M10 WS=13	1
22	451.30.022.000	WINKELSTÜCK 50CCM LC 2001	ANGLE PIECE 50CCM LC 2001	1
23	451.30.023.000	PASSHÜLSE 7X9X10	DOWEL 7X9X10	6(4)
24	0603 100141	CU-DICHRING DIN7603-10X14X1	COPPER GASKET DIN7603-10X14X1	1
25	451.30.025.000	DICHTUNG F. KUPPL.DECKEL 2001	GASKET FOR CLUTCH COVER 2001	1
37	520.31.137.001	PVC-SCHLAUCH 3X5MM	PVC-HOSE 3X5MM	0,20
39	451.30.039.000	MOTORGEHÄUSEDICHTU. 50 LC 2001	ENGINE CASE GASKET 50 LC 2001	1
99	451.30.599.000	DICHTUNGSSATZ KPL. 50 AC 2002	GASKET SET CPL. 50 AC 2002	1

05-450.30.0

05-450.30.0

* NEUTEIL / NEW PART X NACH BEDARF / AS REQUIRED

KURBELWELLE · KOLBEN » CRANKSHAFT · PISTON

50 AC / 2005

AB, CD, EF

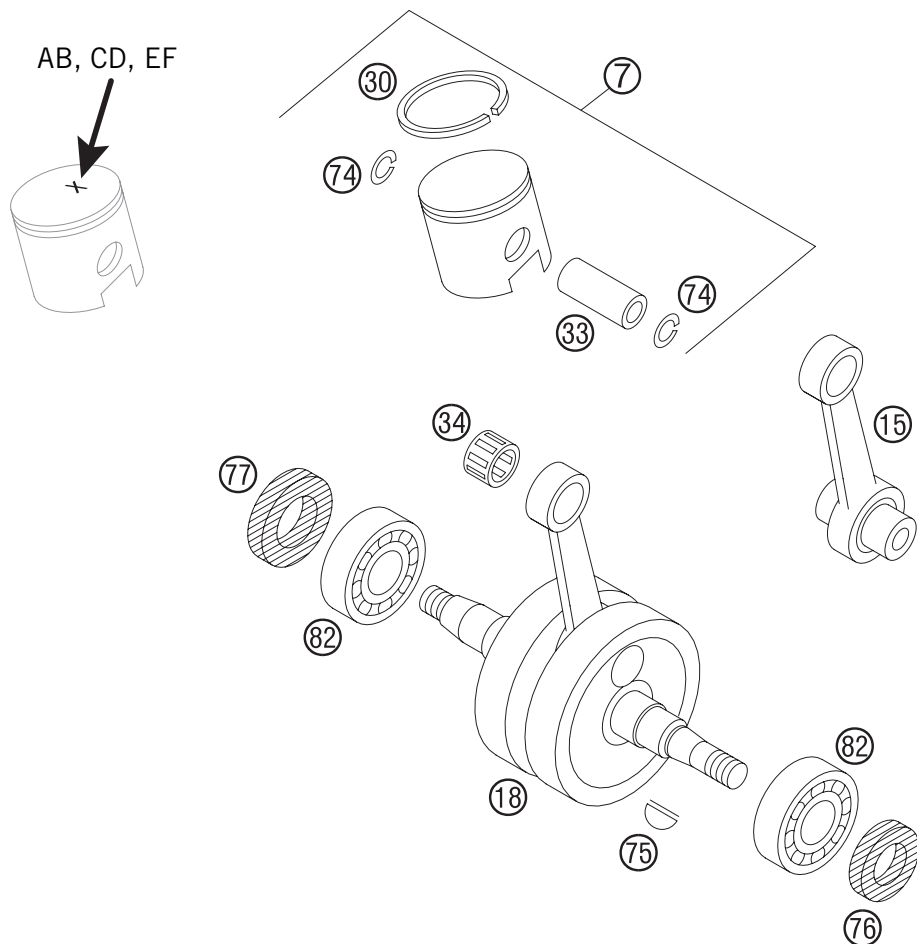

FIG	TEILNR/PARTNR	BEZEICHNUNG	DESCRIPTION	QTY
7	451.30.007.000/ A	KOLBEN KPL.39,5 "AB" 50 LC 01	PISTON CPL.39,5 "AB" 50 LC 01	X
7	451.30.007.000/ C	KOLBEN KPL.39,5 "CD" 50 LC 01	PISTON CPL.39,5 "CD" 50 LC 01	X
7	451.30.007.000/ E	KOLBEN KPL.39,5 "EF" 50 LC 01	PISTON CPL.39,5 "EF" 50 LC 01	X
15	451.30.515.000	PLEUEL-REP.SATZ 50 AC 2002	CON.ROD REPAIR SET 50 AC 2002	1
18	451.30.518.100	KURBELWELLE 50 GS 2002 MINI ADV.	CRANKSHAFT 50 GS 2002 MINI ADV.	1
18	451.30.518.000	KURBELWELLE 50 AC 2002 SENIOR ADV.	CRANKSHAFT 50 AC 2002 SENIOR ADV.	1
30	451.30.030.000	KOLBENRING 50CCM LC 2001	PISTON RING 50CCM LC 2001	1
33	451.30.033.000	KOLBENBOLZEN 50CCM LC 2001	PISTON PIN 50CCM LC 2001	1
34	451.30.034.000	NADELLAGER KOLBENBOLZ.12X15X15	NEEDLE BEAR.PISTONPIN 12X15X15	1
74*	451.30.074.000	KOLBENBOLZENSICHERUNG 2001	CIRCLIP 2001	2
75	451.30.075.000	SCHEIBENFEDER 2,5X3,7	WOODRUFF KEY 2,5X3,7	1
76	451.30.076.000	WELLENDICHRING 15X24X7	OIL SEAL RING 15X24X7	1
77	451.30.077.000	WELLENDICHRING 17X35X7	OIL SEAL RING 17X35X7	1
82	451.30.082.100	KUGELLAGER 17X40X12 2002	BALL BEARING 17X40X12 2002	2

05-450.30.6

05-450.30.6

* NEUTEIL / NEW PART X NACH BEDARF / AS REQUIRED

ZYLINDER · ZYLINDERKOPF » CYLINDER · CYLINDER HEAD

50 AC / 2005

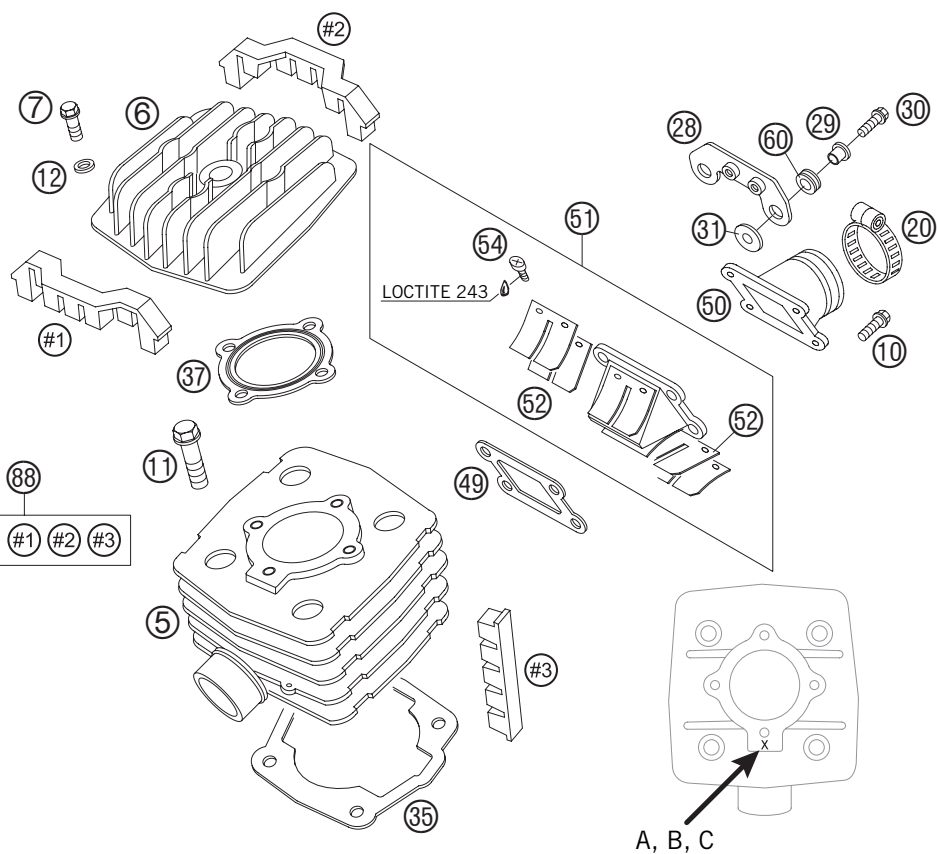

FIG	TEILNR/PARTNR	BEZEICHNUNG	DESCRIPTION	QTY
5	451.30.505.000/ A	ZYLINDER 39,5MM "A" 50 2002	CYLINDER 39,5MM "A" 50 2002	X
5	451.30.505.000/ B	ZYLINDER 39,5MM "B" 50 2002	CYLINDER 39,5MM "B" 50 2002	X
5	451.30.505.000/ C	ZYLINDER 39,5MM "C" 50 2002	CYLINDER 39,5MM "C" 50 2002	X
6	451.30.506.100	ZYLINDERKOPF 50 GS 2002	CYLINDER HEAD 50 GS 2002	1
7	0015 060253	SK.BUNDSCHRAUBE M 6X25 SW=8	HH COLLAR SCREW M 6X25 WS=8	4
10	0015 060203	SK.BUNDSCHRAUBE M 6X20 SW=8	HH COLLAR SCREW M 6X20 WS=8	2
11	0015 080203	SK.BUNDSCHRAUBE M 8X20 SW=10	HH COLLAR SCREW M 8X20 WS=10	4
12	0125 060003	UNTERLEGSCHIBE DIN 125 A 6,4	WASHER DIN0125-A 6,4	4
20	100.01.120.000	SCHLAUCHBINDER 25-40 SGT 4	CLAMP 25-40 SGT 4	1
28	451.39.028.000	HALTEBLECH ZÜNDSPULE 50LC 2001	BRACKET IGNITI. COIL 50LC 2001	1
29	451.39.128.000	BUNDBÜCHSE 6,3X8X7,5	COLLAR BUSHING 6,3X8X7,5	2
30	0015 060303	SK.BUNDSCHRAUBE M 6X30 SW=8	HH COLLAR SCREW M 6X30 WS=8	2
31	0021 060003	SCHEIBE DIN 9021 A 6,4	WASHER DIN9021-A 6,4	2
35	460.30.035.020	ZYLINDERFUSSDICHTUNG 0,2 MM	CYLINDER BASE GASKET 0,2 MM	X
35	460.30.035.050	ZYLINDERFUSSDICHTUNG 0,5 MM	CYLINDER BASE GASKET 0,5 MM	X
37	451.30.537.000	ZYLINDERKOPFDICHTUNG 50 AC 02	CYLINDER HEAD GASKET 50 AC 02	1
49	460.30.049.000	ANSAUGFLANSCHDICHTUNG	INTAKE VALVE GASKET	1
50	451.30.050.000	ANSAUGFLANSCH 50CCM LC 2001	INLET MANIFOLD 50CCM LC 2001	1
51	460.30.051.144	MEMBRANGEHÄUSE KPL. 65SX 2001	MEMBRANE HOUSING CPL.65SX 2001	1
52	460.30.052.000	MEMBRAN LOSE 60/65 CCM	MEMBRANE LOOSE 60/65 CCM	2
54	0985 030063	LINSENSCHRAUBE DIN7985-M 3X6	FLAT HEAD SCREW DIN7985-M 3X6	4
60	310.08.060.000	KABELTÜLLE D=8MM OFFEN	RUBBER SLEEVE D=8MM OPEN	2
88	451.30.588.000	DÄMPFERGUMMI-SET 2002	DAMPING RUBBER-SET 2002	1

05-450.30.7

04-450.30.7

* NEUTEIL / NEW PART X NACH BEDARF / AS REQUIRED

FRISCHÖLSCHMIERUNG » FRESH OIL LUBRICATION

50 MINI ADV. / 2005

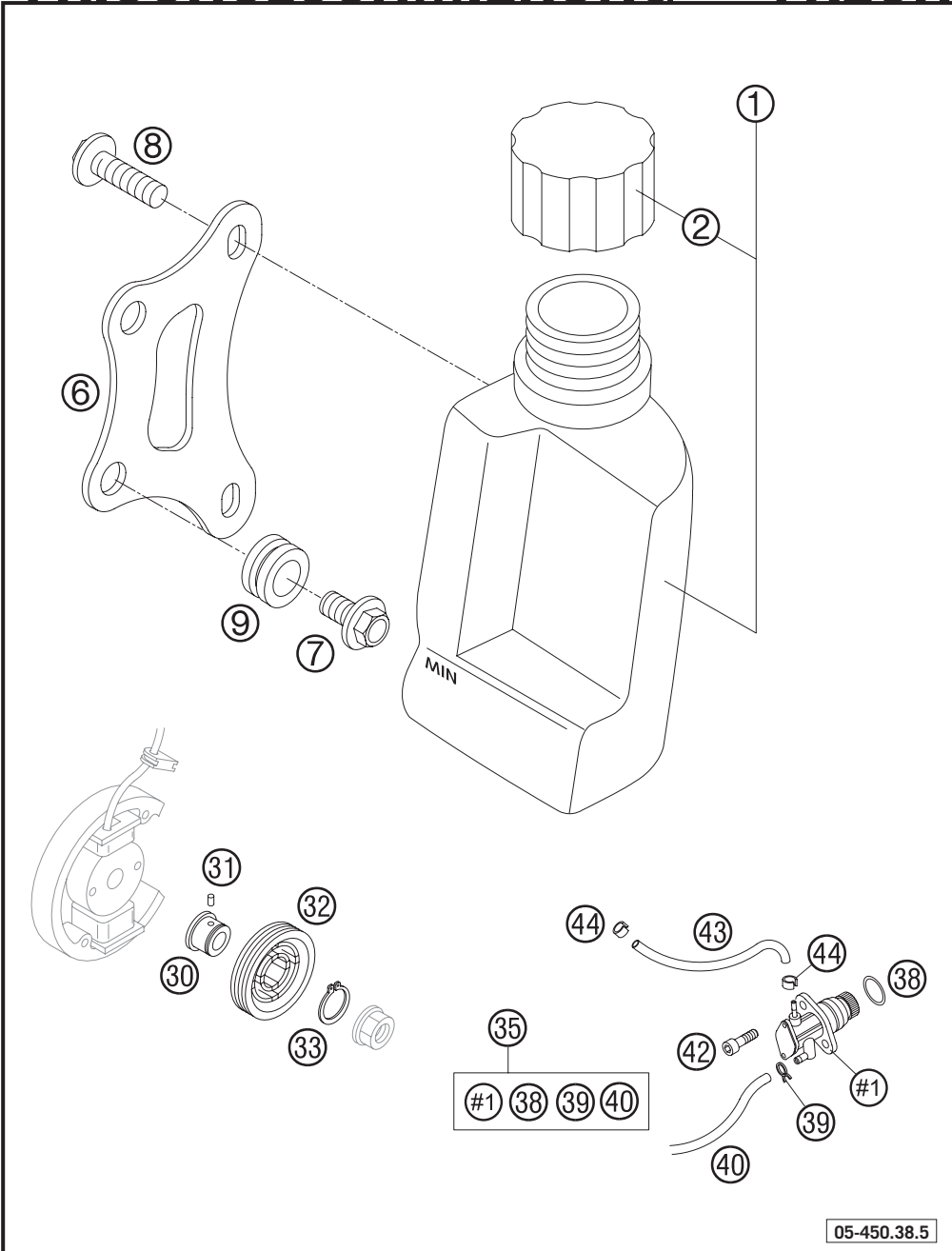

FIG	TEILNR/PARTNR	BEZEICHNUNG	DESCRIPTION	QTY
1	451.38.061.000	ÖLTANK 50 ADV. 'GS' 2002	OIL TANK 50 ADV. 'GS' 2002	1
2	451.38.062.000	ÖLTANKDECKEL 50 GS 2002	OIL TANK COVER 50 GS 2002	1
6	451.38.061.050	HALTEBLECH FÜR ÖLTANK 2002	BRACKET FOR OIL TANK 2002	1
7	0014 060103	SK.BUNDSCHRAUBE M 6X10 SW=8	HH COLLAR SCREW M 6X10 WS=8	2
8	0017 060203	SONDERSCHRAUBE T60 6X20 SW=6	SPECIAL SCREW T60 6X20 WS=6	2
9	310.08.060.000	KABELTÜLLE D=8MM OFFEN	RUBBER SLEEVE D=8MM OPEN	2
30	451.38.064.000	BÜCHSE FÜR ÖLPUMPENRAD	SPACER FOR OIL PUMP GEAR	1
31	0402 030800	PASSSTIFT/LAGERNADEL NRO 3X8,0	RETA.PIN/BEAR.NEEDLE NRO 3X8,0	2
32	451.38.065.000	ÖLPUMPENRAD 50 GS 2002	OIL PUMP GEAR 50 GS 2002	1
33	0472 019100	SICHERUNGSRING DIN0472-19X1	CIRCLIP DIN472 19X1	1
35	451.38.063.000	ÖLPUMPE 50 GS 2002	OIL PUMP 50 GS 2002	1
38	0770 191016	O-RING 19,10X1,60 NBR 70	O-RING 19,10X1,60 NBR 70	1
39	580.07.017.000	YDNAC KLAMMER 10101 (9MM)	YDNAC CLAMP 10101 (9MM)	2
40	451.38.067.000	SCHLAUCH 5X9MM	HOSE 5X9MM	1
42	0912 050143	ISK.SCHRAUBE DIN0912-M 5X14	AH SCREW DIN912 M5X14	2
43	451.38.068.000	FORMSCHLAUCH VERG.-PUMPE 2X5MM	PREFORM. HOSE CARB.-PUMP 2X5MM	1
44	451.38.069.000	KLAMMER 5 FÜR ÖLPUMPE	CLAMP 5 FOR OIL PUMP	2

05-450.38.5

03-450.38.5

* NEUTEIL / NEW PART

X NACH BEDARF / AS REQUIRED



ACHTUNG !!!
Vor dem Einbau des Vergasers, Bedüsung kontrollieren.
CAUTION !!!
Before mounting the carburetor, check the jetting.

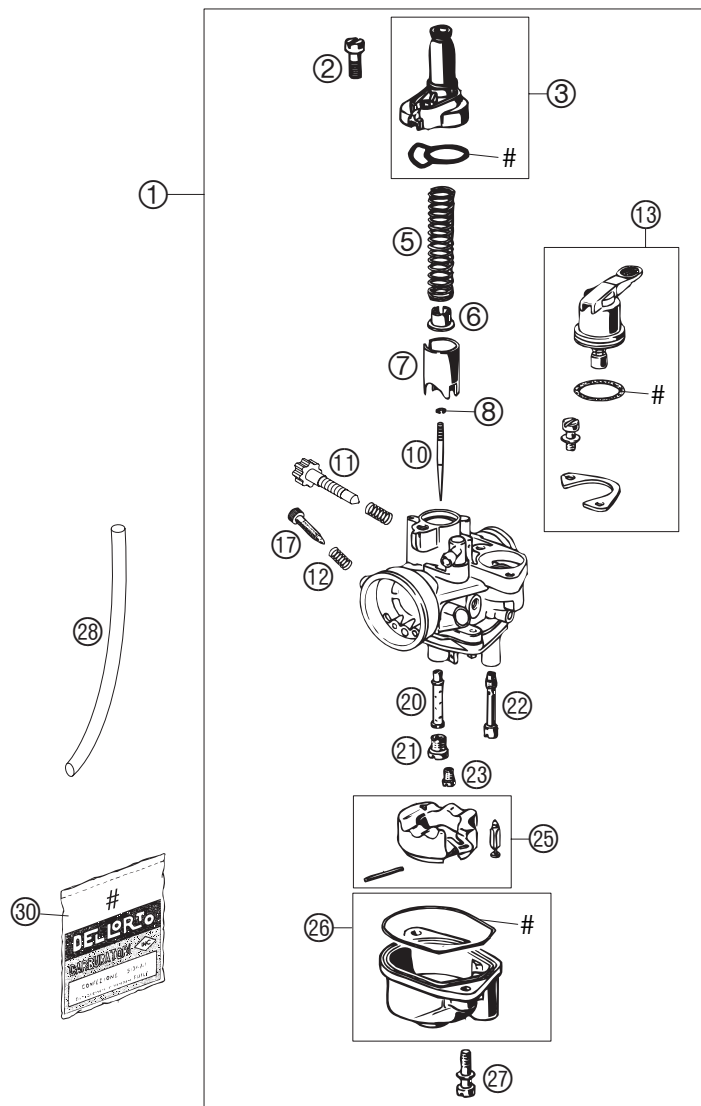

05-450.31.0

FIG	TEILNR/PARTNR	BEZEICHNUNG	DESCRIPTION	QTY
1*	451.31.001.300	VERGASER DELLORTO PHVA 12XS 05 MINI ADV.	CARBURETOR DELLO. PHVA 12XS 05 MINI ADV.	1
1	451.31.001.000	VERGASER DELLORTO 14 PHVA DS SENIOR ADV.	CARBURETOR DELLORTO 14PHVA DS SENIOR ADV.	1
2	0084 050163	ZYL.SCHRAUBE DIN0084-M 5X16 A	CYL.HEAD SCREW DIN0084-M 5X16A	1
3	451.31.527.000	VERGASERDECKEL DELLORTO 12-14	CARBURETOR COVER DELLOR. 12-14	1
5	451.31.530.000	SCHIEBERFEDER	SPRING	1
6	451.31.531.000	FEDERTASSE	SPRING CAP	1
7	451.31.535.000	GASSCHIEBER 40	THROTTLE VALVE 40	1
8	451.31.545.000	KLEMMFEDER	CLAMP SPRING	1
10	451.31.534.010	DÜSENNADEL A10	JET NEEDLE A10	1
11	451.31.517.000	LEERLAUFREGULIERSCHRAUBE	IDLE ADJUST SCREW	1
12	451.31.516.000	FEDER FÜR GEMISCHREGULIERSCHR.	SPRING FOR ADJUST SCREW	1
13	451.31.548.000	STARTHEBEL KPL. DELLORTO 12-14	STARTING LEVER CPL. DELL.12-14	1
17*	451.31.617.000	GEMISCHREGULIERSCHRAUBE	ADJUST SCREW	1
20	451.31.536.000	ZERSTÄUBER 211FA	ATOMIZER 211FA	1
21	590.30.054.000	DÜSE 60 DELLORTO M6X0,75	JET 60 DELLORTO M6X0,75	X
21*	451.31.023.065	HAUPTDÜSE 65 DELLORTO MINI ADV.	MAIN JET 65 DELLORTO MINI ADV.	1
21	451.31.023.070	HAUPTDÜSE 70 DELLORTO	MAIN JET 70 DELLORTO	X
21	570.31.523.080	HAUPTDÜSE 80 SENIOR ADV.	MAIN JET 80 SENIOR ADV.	1
22	451.31.551.060	STARTDÜSE 60	STARTING JET 60	1
23	451.31.507.035	LEERLAUFDÜSE 35	IDLING JET 35	X
23	451.31.507.038	LEERLAUFDÜSE 38 MINI ADV.	IDLING JET 38 MINI ADV.	1
23	451.31.507.045	LEERLAUFDÜSE 45 SENIOR ADV.	IDLING JET 45 SENIOR ADV.	1
25	451.31.509.000	SCHWIMMER KPL.	FLOAT CPL.	1
26	451.31.511.000	SCHWIMMERGEHÄUSE DELLO. 12-14	FLOAT BOWL DELLORTO 12-14	1
27	0084 040203	ZYL.SCHRAUBE DIN0084-M 4X20 A	CYL.SCREW DIN0084-M 4X20 A	2
28	520.31.137.001	PVC-SCHLAUCH 3X5MM	PVC-HOSE 3X5MM	0,24
30	451.31.599.000	DICHTUNGSSATZ DELLO.12-14 PHVA	GASKET SET DELLORTO 12-14 PHVA	1

05-450.31.0

* NEUTEIL / NEW PART X NACH BEDARF / AS REQUIRED

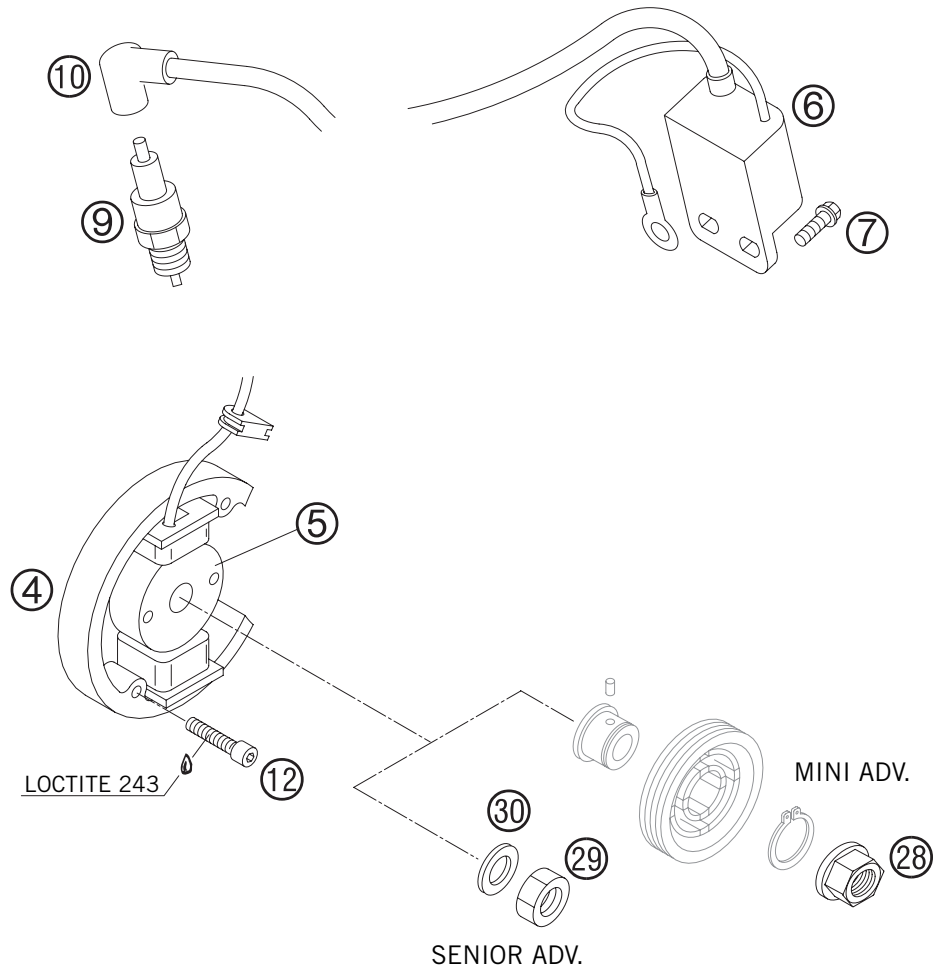

FIG	TEILNR/PARTNR	BEZEICHNUNG	DESCRIPTION	QTY
4	451.39.004.000	STATOR 50CCM LC 2001	FLYWHEEL STATOR 50CCM LC 2001	1
5	451.39.005.100	ROTOR 50 2004	FLYWEEL ROTOR 50 2004	1
6	451.39.006.000	ZÜNDSPULE 50CCM LC 2001	IGNITION COIL 50CCM LC 2001	1
7	0015 060123	SK.BUNDSCHRAUBE M 6X12 SW=8	HH COLLAR SCREW M 6X12 WS=8	2
9	543.31.093.410	ZÜNDKERZE NGK BR8ECM	SPARK PLUG NGK BR8ECM	1
10	545.31.010.000	KERZENSTECKER LB05EMH NGK	SPARK PLUG CAP LB05EMH NGK	1
12	0912 050253	ISK.SCHRAUBE DIN 912 M5X25	AH SCREW DIN0912-M 5X25	2
28	584.14.030.000	SK-BUNDMUTTER M10X1,25 SW=13	HH COLLAR NUT M10X1,25 WS=13	1
29	451.30.028.000	SPEZIALMUTTER M10X1,25X6	SPECIAL NUT M10X1,25X6	1
30	451.32.020.000	SCHEIBE 10,4X16,8X0,4	WASHER 10,4X16,8X0,4	1

05-450.39.0

05-450.39.0

* NEUTEIL / NEW PART X NACH BEDARF / AS REQUIRED

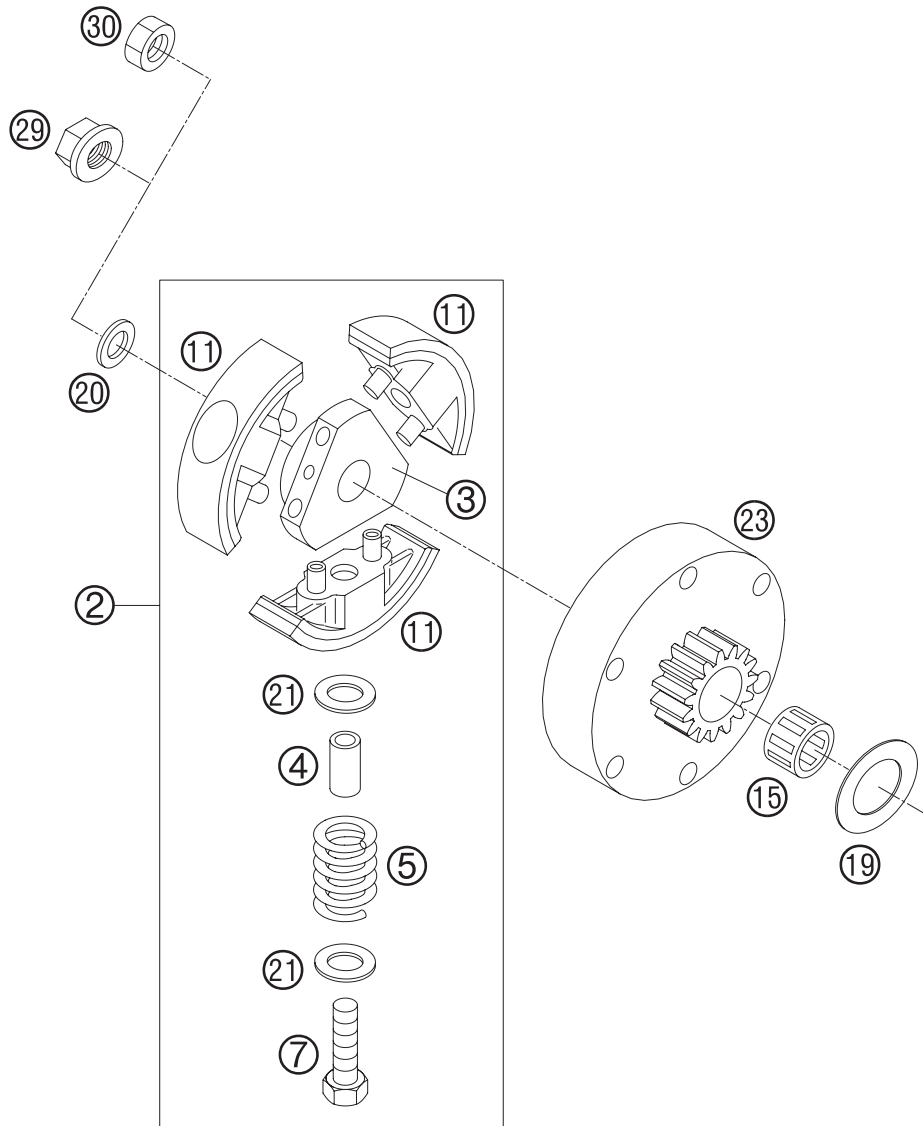

FIG	TEILNR/PARTNR	BEZEICHNUNG	DESCRIPTION	QTY
2	451.32.502.044	FLIEHKRAFTKUPPLUNG KPL.50 2002	CLUTCH CPL.50 2002	1
3	451.32.002.000	KUPPLUNGSNABE 50 LC 2002	CLUTCH HUB 50 LC 2002	1
4	451.32.004.000	DISTANZBÜCHSE 6X8X19	SPACER 6X8X19	3
5	451.32.005.100	KUPPLUNGSFEDER 50 GS 2002	CLUTCH SPRING 50 GS 2002	3
7	0933 060253	SK.SCHRAUBE DIN0933-M 6X25	HH SCREW DIN0933-M 6X25	3
11	451.32.011.100	KUPPLUNGSBACKE 50 LC 2002	CLUTCH BLOCK 50 LC 2002	3
15	451.32.015.000	NADELLAGER 15X18X17	NEEDLE BEARING 15X18X17	1
19	470.33.043.000	ANLAUFSCHIEBE 15X25X0,5	STOP DISC 15X25X0,5	X
19	451.32.020.060	DISTANZSCHEIBE 15X25X0,6	SPACER WASHER 15X25X0,6	X
19	470.33.040.000	ANLAUFSCHIEBE 15X25X1	STOP DISC 15X25X1	X
20	451.32.020.000	SCHEIBE 10,4X16,8X0,4	WASHER 10,4X16,8X0,4	1
21	451.32.120.000	SCHEIBE 8X15,3X0,5	WASHER 8X15,3X0,5	6
23	451.32.023.016	KUPPLUNGSTROMMEL 16-Z	CLUTCH DRUM 16-T	1
29	584.14.030.000	SK-BUNDMUTTER M10X1,25 SW=13 MINI ADV.	HH COLLAR NUT M10X1,25 WS=13 MINI ADV.	1
30	451.30.029.000	SPEZIALMUTTER 10X1,25X8 SENIOR ADV.	SPECIAL NUT 10X1,25X8 SENIOR ADV.	1

05-450.32.0

05-450.32.0

* NEUTEIL / NEW PART X NACH BEDARF / AS REQUIRED

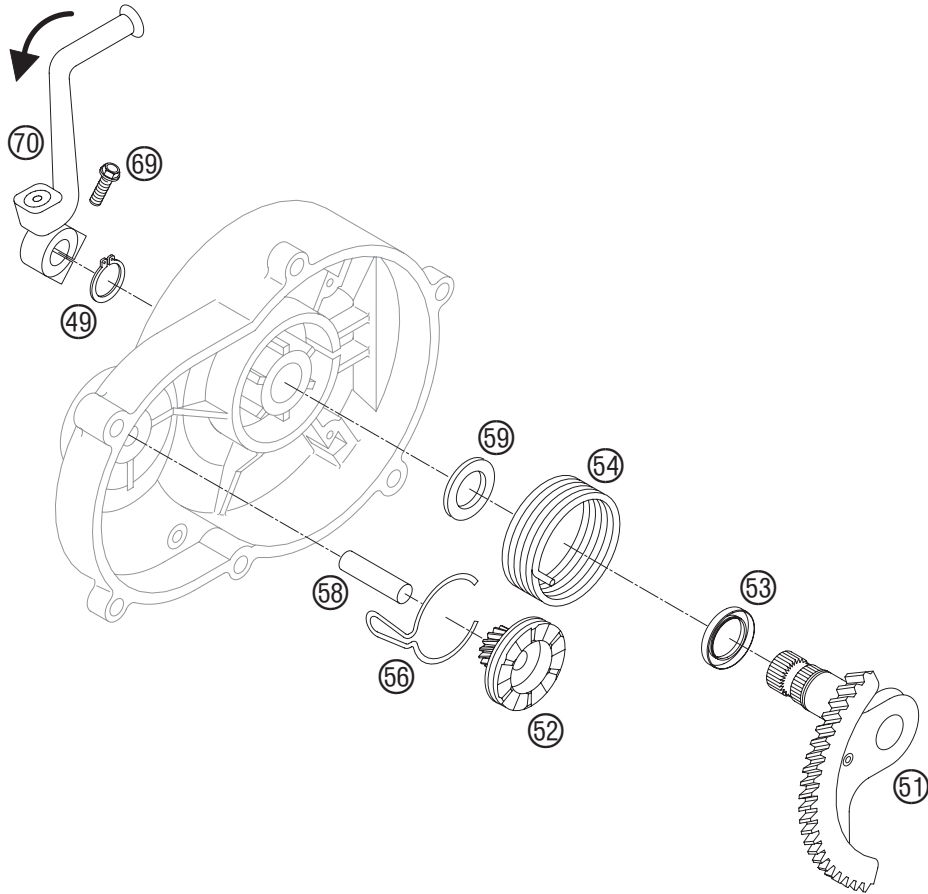

FIG	TEILNR/PARTNR	BEZEICHNUNG	DESCRIPTION	QTY
49	0471 150010	SICHERUNGSRING DIN0471-15X1	CIRCLIP DIN0471-15X1	1
51	451.33.050.100	KICKSTARTERWELLE 50 2004	KICKSTARTER SHAFT 50 2004	1
52	451.33.052.000	SPERRAD FÜR KICKSTARTER 2001	KICKSTARTER SLEEVE 2001	1
53	451.35.056.000	WELLENDICHTRING 16X22X4	OIL SEAL RING 16X22X4	1
54	451.33.054.000	FEDER FÜR KICKSTARTER 2001	KICKSTARTER SPRING 2001	1
56	451.33.056.000	SPERRADFEDER 2001	KICKSTARTER SLEEVE SPRING 2001	1
58	451.33.058.000	LAGERBOLZEN FÜR SPERRAD 2001	BEARING BOLT F. KICKST SLEE.01	1
59	470.33.041.000	ANLAUFSCHEIBE 16X26X1	STOP DISC 16X26X1	1
69	0015 060203	SK.BUNDSCHRAUBE M 6X20 SW=8	HH COLLAR SCREW M 6X20 WS=8	1
70	451.33.070.000	KICKSTARTER 50CCM LC 2001	KICKSTARTER 50CCM LC 2001	1

04-450.33.0

05-450.33.0

* NEUTEIL / NEW PART X NACH BEDARF / AS REQUIRED

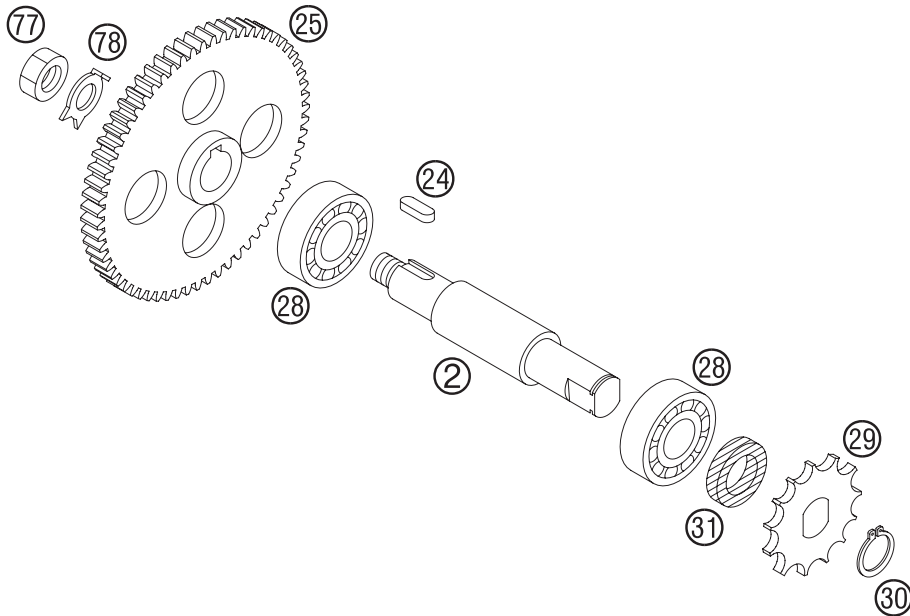
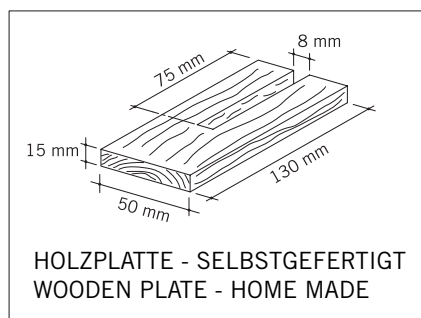
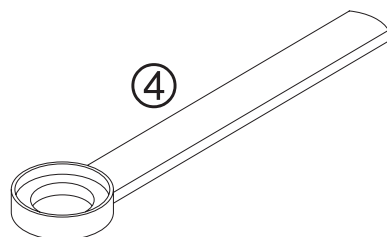
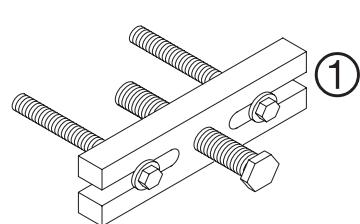

FIG	TEILNR/PARTNR	BEZEICHNUNG	DESCRIPTION	QTY
2	451.33.002.000	ABTRIEBSWELLE 50CCM LC 2001	COUNTER SHAFT 50CCM LC 2001	1
24	451.33.024.000	SCHEIBENFEDER 5X5X12	WOODRUFF KEY 5X5X12	1
25	451.32.024.057	PRIMÄRRAD 57-Z	PRIMARY GEAR 57-T	1
28	451.33.028.000	KUGELLAGER 15X35X11	BALL BEARING 15X35X11	2
29	451.33.029.009	KETTENRITZEL 9-Z 50 LC 2001	SPROCKET 9-T 50 LC 2001	X
29	451.33.029.010	KETTENRITZEL 10-Z 50 LC 2001	SPROCKET 10-T 50 LC 2001	X
29	451.33.029.011	KETTENRITZEL 11-Z 50 LC 2001	SPROCKET 11-T 50 LC 2001	1
29	451.33.029.012	KETTENRITZEL 12-Z 50 LC 2001	SPROCKET 12-T 50 LC 2001	X
29	451.33.029.013	KETTENRITZEL 13-Z 50 LC 2001	SPROCKET 13-T 50 LC 2001	X
30	0471 150010	SICHERUNGSRING DIN0471-15X1	CIRCLIP DIN0471-15X1	1
31	451.33.031.000	WELLENDICHRING 15X24X5	OIL SEAL RING 15X24X5	1
77	460.30.029.000	SK.MUTTER 14X1,25X7 SW=22	HH NUT 14X1,25X7 WS=22	1
78	460.30.078.000	SICHERUNGSBLECH D=14MM	LOCKING PLATE D=14MM	1

02-450.33.1

02-450.33.1

* NEUTEIL / NEW PART X NACH BEDARF / AS REQUIRED



HOLZPLATTE - SELBSTGEFERTIGT
WOODEN PLATE - HOME MADE

FIG	TEILNR/PARTNR	BEZEICHNUNG	DESCRIPTION	QTY
1	590.29.021.044	ABZIEHER PRIMÄRRAD KPL. MIT M4, M5, M6 SCHRAUBEN	EXTRACTOR PRIM. GEAR CPL. WITH M4, M5, M6 SCREWS	1
2	6 899 785	LOCTITE 243 BLAU 6CCM	LOCTITE 243 BLUE 6CCM	1
4	451.12.021.000	HALTESCHLÜSSEL F. ROTOR 2002	HOLDING SPANNER F. FLYWHEEL 02	1
5	451.29.006.000	EINSTELLEHRE 50SX MINI 2001	ADJUSTING PLATE 50SX MINI 2001	1

05-450.29.0

05-450.29.0

* NEUTEIL / NEW PART X NACH BEDARF / AS REQUIRED

A large empty rectangular box with a black border, intended for taking notes.



KTM-Sportmotorcycle AG
A-5230 Mattighofen
www.ktm.at

KTM Group Partner



3208158



Art.Nr.: 3.208.158

04/2004

Foto: Mitterbauer