

SPAREPARTSMANUAL2005



ERSATZTEILKATALOG: MOTOR
SPARE PARTS MANUAL: ENGINE

625 SMC

625 SXC

640 ADVENTURE

640 DUKE

640 LC4 ENDURO

640 LC4 SUPERMOTO

660 SMC

KTM

MOTORGEHÄUSE 625/640
ENGINE CASE 625/640

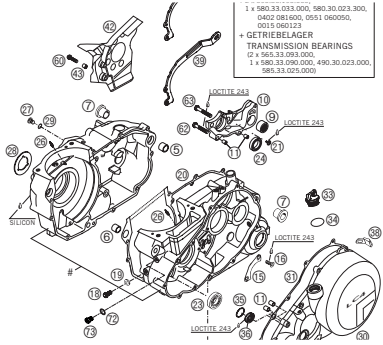

1 x 580.33.023.000, 580.30.023.300,
0402 081600, 0551 060050,
0019 060123
+ GETRIEBELAGER
TRANSMISSION BEARINGS
12 x 580.33.090.000, 490.30.023.000,
585.33.025.000

4

MOTORGEHÄUSE 660
ENGINE CASE 660

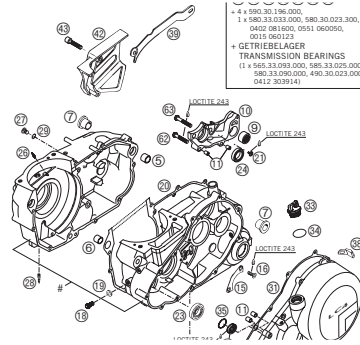

4 x 580.30.196.000,
1 x 580.33.023.000, 580.30.023.300,
0402 081600, 0551 060050,
0019 060123
+ GETRIEBELAGER
TRANSMISSION BEARINGS
11 x 585.33.093.000, 585.33.025.000,
580.33.090.000, 490.30.023.000,
0412 203914

6

KURBELWELLE, KOLBEN 625/640
CRANKSHAFT, PISTON 625/640

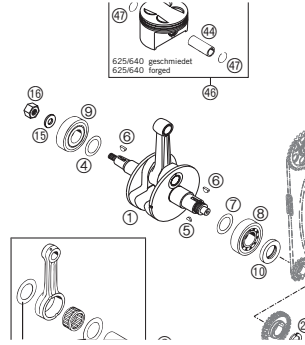

625/640 geschmiedet
625/640 forged

8

KURBELWELLE, KOLBEN 660
CRANKSHAFT, PISTON 660

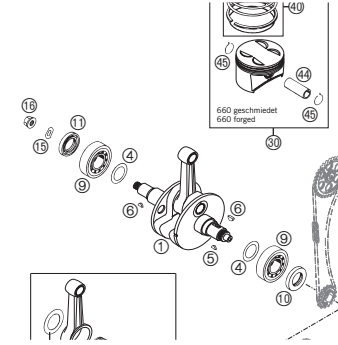

660 geschmiedet
660 forged

9

AUSGLEICHSWELLE
BALANCER SHAFT

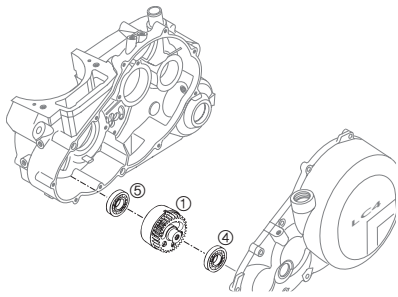

10

ZYLINDER 625/640
CYLINDER 625/640

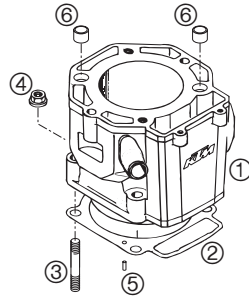

11

ZYLINDER 660
CYLINDER 660

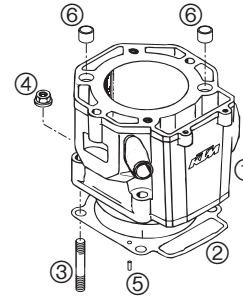

12

ZYLINDERKOPF 625/640
CYLINDER HEAD 625/640

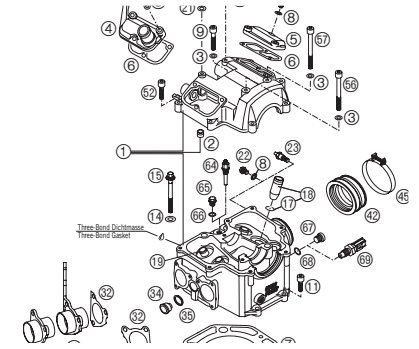

13

ZYLINDERKOPF 660
CYLINDER HEAD 660

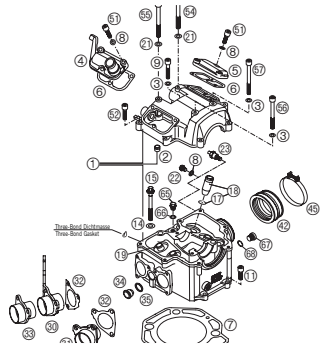

15

SEKUNDÄRLUFTSYSTEM
SECONDARY AIR SYSTEM

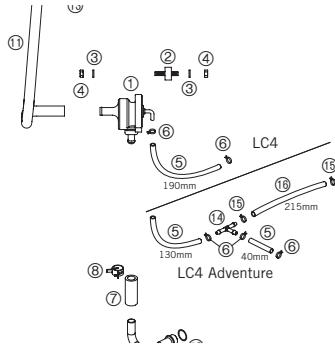

17

VENTILTRIEB
VALVE DRIVE

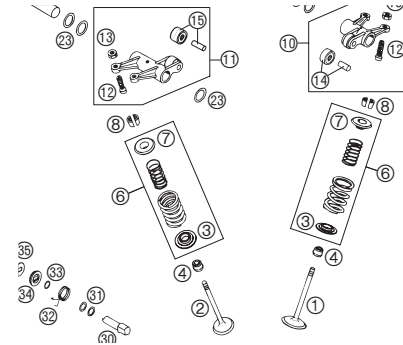

18

STEUERTRIEB
TIMING VALVE

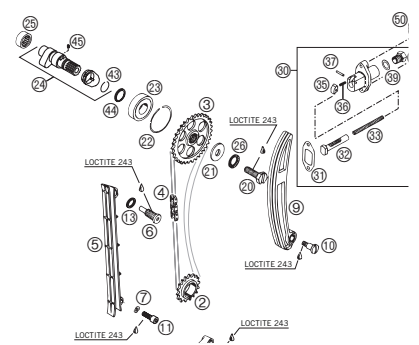

19

SCHMIERSYSTEM 625/640
LUBRICATING SYSTEM 625/640

21

SCHMIERSYSTEM 660
LUBRICATING SYSTEM 660

22

MOTORENTLÜFTUNG
BREATHER SYSTEM

23

VERGASER KEIHIN 625/660
CARBURETOR KEIHIN 625/660

24

VERGASER MIKUNI 640
CARBURETOR MIKUNI 640

26

ELECTRONIC POWER CONTROL 640
ELECTRONIC POWER CONTROL 640

28

ZÜNDANLAGE KOKUSAN 625/640
IGNITION SYSTEM KOKUSAN 625/640

29

ZÜNDANLAGE KOKUSAN 660
IGNITION SYSTEM KOKUSAN 660

30

ELEKTROSTARTER 625/640
ELECTRIC STARTER 625/640

31

KUPPLUNG 625/640
CLUTCH 625/640

32

KUPPLUNG 660
CLUTCH 660

33

KICKSTARTER
KICKSTARTER

34

GETRIEBE I - ANTRIEBSWELLE
TRANSMISSION I - MAIN SHAFT

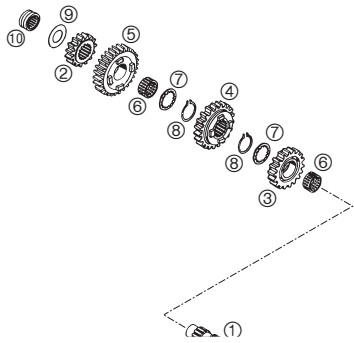

35

GETRIEBE II - ABTRIEBSWELLE 625/640
TRANSMISSION II - COUNTER SHAFT 625/640

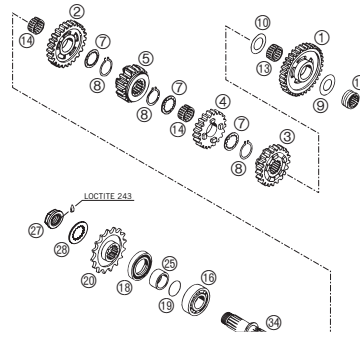

36

GETRIEBE II - ABTRIEBSWELLE 660
TRANSMISSION II - COUNTER SHAFT 660

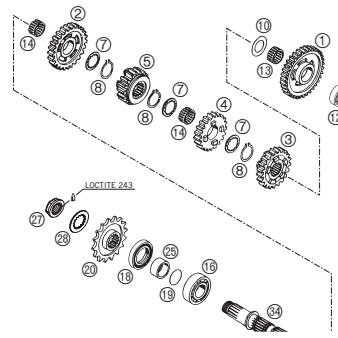

37

SCHALTUNG 625/640
SHIFTING MECHANISM 625/640

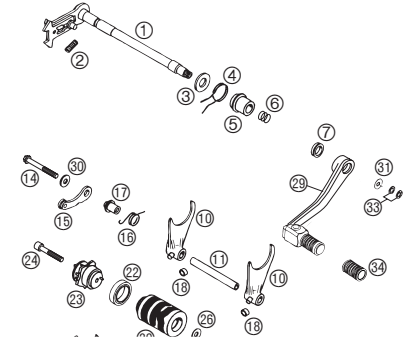

38

SCHALTUNG 660
SHIFTING MECHANISM 660

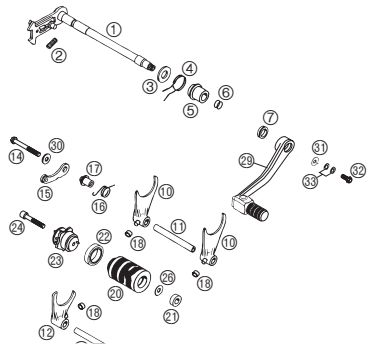

39

WASSERPUMPE
WATERPUMP

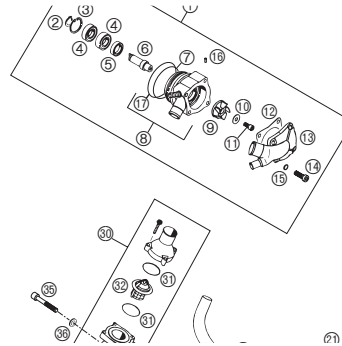

40

KÜHLSYSTEM
COOLING SYSTEM

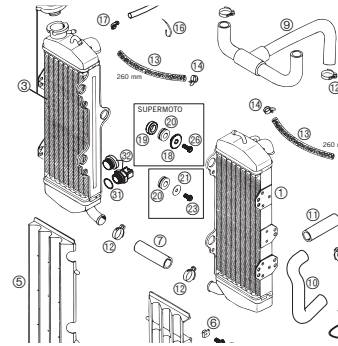

41

SPEZIALWERKZEUGE
SPECIAL TOOLS

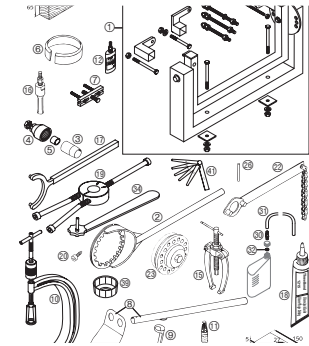

42



Alle enthaltenen Angaben sind unverbindlich. Die KTM-Sportmotorcycle AG behält sich insbesondere das Recht vor, technische Angaben, Preise, Farben, Formen, Materialien, Dienst- und Serviceleistungen, Konstruktionen, Ausstattungen und ähnliches ohne vorheriger Ankündigung und ohne Angabe von Gründen zu ändern bzw. ersatzlos zu streichen, sie an lokale Gegebenheiten anzupassen sowie die Fertigung eines bestimmten Modells ohne vorherige Ankündigung einzustellen. KTM übernimmt keine Haftung für Liefermöglichkeiten, Abweichungen von Abbildungen und Beschreibungen sowie Druckfehler und Irrtümer. Die abgebildeten Modelle enthalten zum Teil Sonderausstattungen, die nicht zum serienmäßigen Lieferumfang gehören. © 2004 by KTM-SPORTMOTORCYCLE AG, Mattighofen AUSTRIA; Alle Rechte vorbehalten; Nachdruck, auch auszugsweise, nur mit schriftlicher Genehmigung von KTM-SPORTMOTORCYCLE AG, Mattighofen

All information contained is without obligation. KTM-Sportmotorcycle AG particularly reserves the right to modify any equipment, technical specifications, prices, colors, shapes, materials, services, service work, constructions, equipment and the like so as to adapt them to local conditions or to cancel any of the above items, all without previous announcement and without giving reasons. KTM may stop manufacturing certain models without previous notice. KTM shall not be held liable for any deviations of availability and/or ability to deliver, illustrations, descriptions, printing and/or other errors. The illustrated models partly contain extra equipment, which is not applied to standard models.

© 2004 by KTM-SPORTMOTORCYCLE AG, Mattighofen AUSTRIA; All rights reserved; Reprint, also in extracts, with written allowance of KTM-SPORTMOTORCYCLE AG, Mattighofen only.

MOTORGEHÄUSE » ENGINE CASE

625/640 / 2005

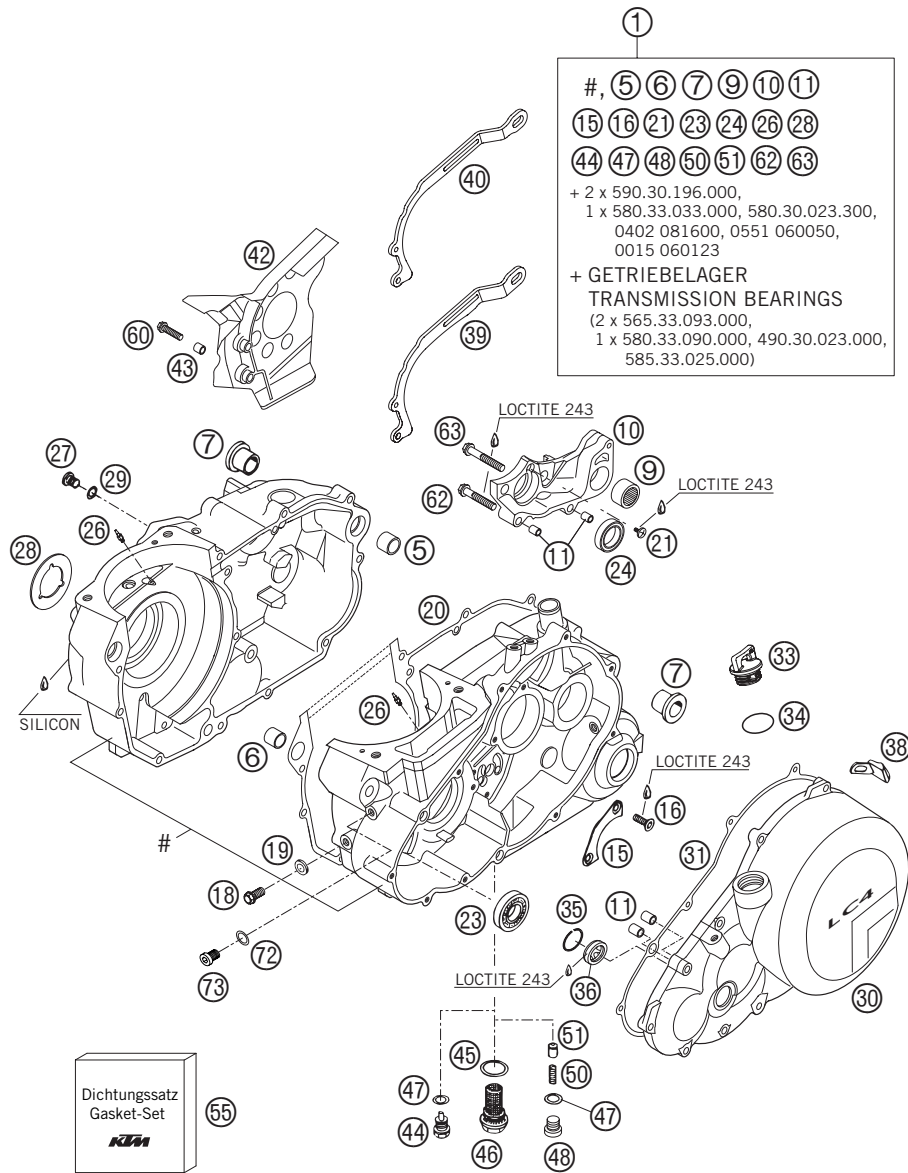

05-584.30.0

FIG	TEILNR/PARTNR	BEZEICHNUNG	DESCRIPTION	QTY
1*	584.30.000.344/23	MOTORGEH. KPL. M.LAGER LC4 05 GRAU	ENGINE CASE CPL.W.BEAR. LC4 05 GREY	1
5	501.30.027.000	PASSHÜLSE 19 X15,1X12	DOWEL 19 X15,1X12	1
6	510.30.026.100	PASSHÜLSE 17 X 13 X 12	DOWEL 17 X 14 X 12	1
7	501.30.010.000	GEHÄUSEBÜCHSE	CRANK CASE BUSH	2
9	580.33.097.000	NADELLAGER HK 2216	NEEDLE BEARING HK 2216	1
10	583.30.011.000	SCHALTUNGSTRÄGER LC4'94	SHIFT MECHANISM SUPPORT LC4'94	1
11	490.30.090.000	PASSHÜLSE 9,8 X 7 X 10	DOWEL 9,8 X 7 X 10	4
15	565.30.017.000	HALTEBLECH	RETAINING PLATE	1
16	0991 060166	SENKSCHR. DIN7991 M6X16 10.9	FL.HEAD SCR.DIN7991-M6X16 10.9	2
18	0015 080163	SK.BUNDSCHRAUBE M 8X16 SW=10	HH COLLAR SCREW M 8X16 WS=10	1
19	0603 082121	CU-DICHRING DIN7603- 8X12X1	SEAL RING CU DIN7603- 8X12X1	1
20	585.30.039.300	GEHÄUSEDI. POLYSTRAT 0,43MM 04	ENGI.CASE GASKET POLY. 0,43 04	1
21	0985 050103	LINSENSCHRAUBE DIN7985-M 5X10	OVAL HEAD SCR. DIN7985-M 5X10	1
23	0412 174012	ZYL.ROLLENLAGER NJ203 ECP C3	CYLIND.ROLL.NJ 203 ECP/C3 2001	1
24	0625 618050	RILLENKUGELLAGER 61805 C3	BALL BEARING 61805 C3	1
26*	600.30.064.070	ÖLSPRITZDÜSE 70 M6X0,75 SW8 03	OIL JET 70 M6X0,75 WS8 03	2
28	584.40.091.000	ANLAUFSCHLEIBE 33 X 58 X 1,5	STOP DISK 33 X 58 X 1,5	1
30	583.30.101.244/23	KUPPLUNGSDECKEL KPL. GRAU 03 MIT ÖLSCHAUGLAS	CLUTCH COVER CPL. GREY 03 WITH OIL INSPECTION GLASS	1
31	585.30.025.000	KUPPLUNGSDECKELDICHUNG 2001	CLUTCH COVER GASKET 2001	1
33*	580.30.020.100	ÖLEINFÜLLSCHR. KPL. M24X3	PLUG CPL. M24X3	1
34	0770 191015	O-RING 19,00X3,00 NBR	O-RING 19,00X3,00 NBR	1
35	610.30.019.050	SICHERUNGSRING ÖLSCHAUGLAS 05	CIRCLIP OIL LEVEL GLASS 03	1
36	590.30.019.000	ÖLSCHAUGLAS G 1777 Y	OIL LEVEL GLASS G 1777 Y	1
38	583.33.041.000	ANSCHLAGGUMMI	BUMP RUBBER	1
39	584.30.047.200	KETTEND.-BLECH 15/16Z 92MM 03	CHA.DAMPERSHEET 15/16T 92MM 03	1
40	587.30.047.100	KETTENDÄMPF.-BLECH 17Z 92MM 03	CHAIN DAMPERSHEET 17T 92MM 03	1
42*	584.30.060.100	KETTENABDECKUNG 05	SPROCKET COVER 05	1
43	546.13.038.150	BÜCHSE 6,5X8X11	BUSHING 6,5X8X11	2
44	580.30.021.000	ÖLABLASSCHR.B.M.MAGNET M 12X1,5	OILDRAIN PLUG W.MAG. M 12X1,5	1
45	580.38.017.100	CU-DICHRING DIN7603-22X27X2	CU-SEAL RING DIN7603-22X27X2	1
46	580.38.019.100	ÖLVERSCHLUSSSCHRAUBE M22X1,5	OIL DRAIN PLUG M22X1,5	1
47	580.38.022.000	CU-DICHRING DIN7603-12X18X1,5	CU-SEAL RING DIN7603-12X18X1,5	2
48	0908 120153	VERSCHL.SCHR. DIN0908-M12X1,5	PLUG DIN0908-M12X1,5	1

05-584.30.0

* NEUTEIL / NEW PART X NACH BEDARF / AS REQUIRED

MOTORGEHÄUSE » ENGINE CASE

625/640 / 2005

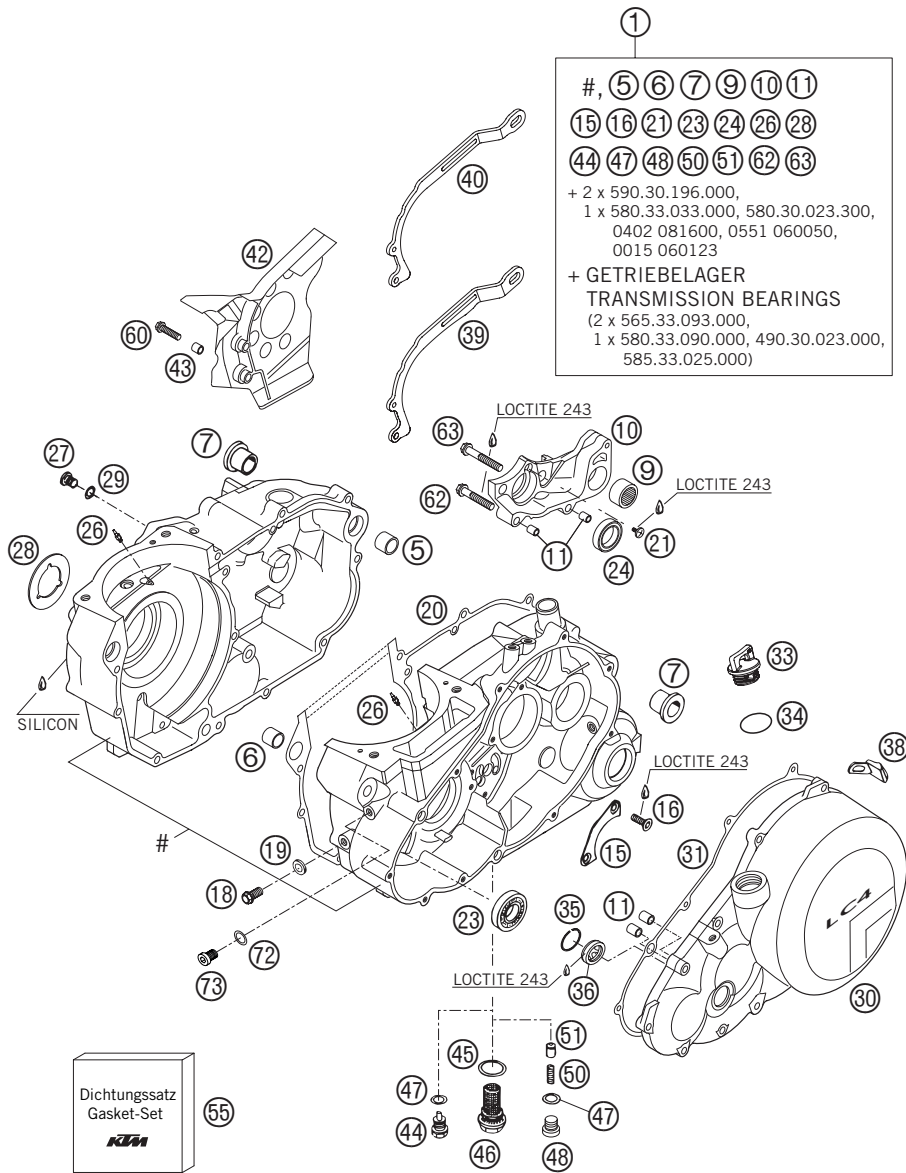

05-584.30.0

FIG	TEILNR/PARTNR	BEZEICHNUNG	DESCRIPTION	QTY
50	580.38.023.300	DRUCKFEDER L=25MM D=1MM	PRESSURE SPRING L=25MM D=1MM	1
51	580.38.028.000	VENTILKOLBEN D=10MM	VALVE PISTON D=10MM	1
55	584.30.099.200	DICHTUNGSSATZ LC4 2003	GASKET SET LC4 2003	1
60	0015 060253	SK.BUNDSCHRAUBE M 6X25 SW=8	HH COLLAR SCREW M 6X25 WS=8	10
61	0015 060303	SK.BUNDSCHRAUBE M 6X30 SW=8	HH COLLAR SCREW M 6X30 WS=8	6
62	0015 060353	SK.BUNDSCHRAUBE M 6X35 SW=8	HH COLLAR SCREW M 6X35 WS=8	2
63	0015 060403	SK.BUNDSCHRAUBE M 6X40 SW=8	HH COLLAR SCREW M 6X40 WS=8	1
66	0015 060553	SK.BUNDSCHRAUBE M 6X55 SW=8	HH COLLAR SCREW M 6X55 WS=8	4
68	0015 060653	SK.BUNDSCHRAUBE M 6X65 SW=8	HH COLLAR SCREW M 6X65 WS=8	1
71	0015 060303	SK.BUNDSCHRAUBE M 6X30 SW=8	HH COLLAR SCREW M 6X30 WS=8	2
71	0015 060353	SK.BUNDSCHRAUBE M 6X35 SW=8	HH COLLAR SCREW M 6X35 WS=8	2
71	0015 060353	SK.BUNDSCHRAUBE M 6X35 SW=8	HH COLLAR SCREW M 6X35 WS=8	2
71	0015 060353	SK.BUNDSCHRAUBE M 6X35 SW=8	HH COLLAR SCREW M 6X35 WS=8	2
71	0015 060353	SK.BUNDSCHRAUBE M 6X35 SW=8	HH COLLAR SCREW M 6X35 WS=8	2
72*	0603 082131	CU-DICHRING DIN7603- 8,2X13X1	COPPER GASK.DIN7603- 8,2X13X1	1
73*	0908 080013	VERSCHLUSSCHR. M8X1 DIN 908	PLUG M8X1 DIN 908	1

05-584.30.0

* NEUTEIL / NEW PART X NACH BEDARF / AS REQUIRED

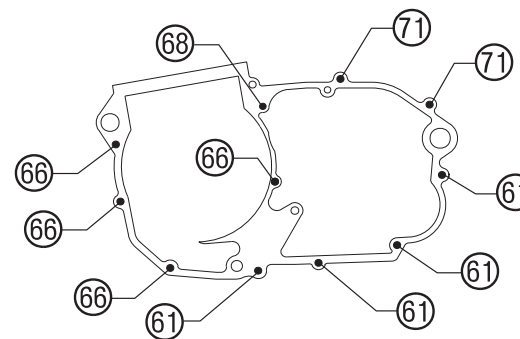

03-584.30.9

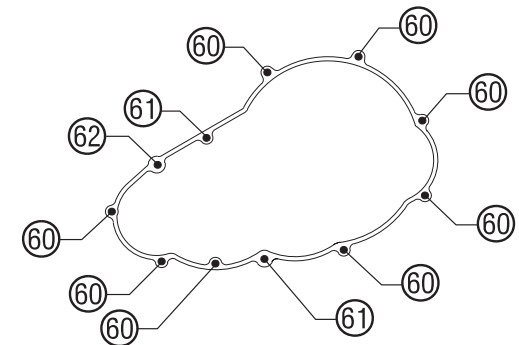

MOTORGEHÄUSE » ENGINE CASE

660 / 2005

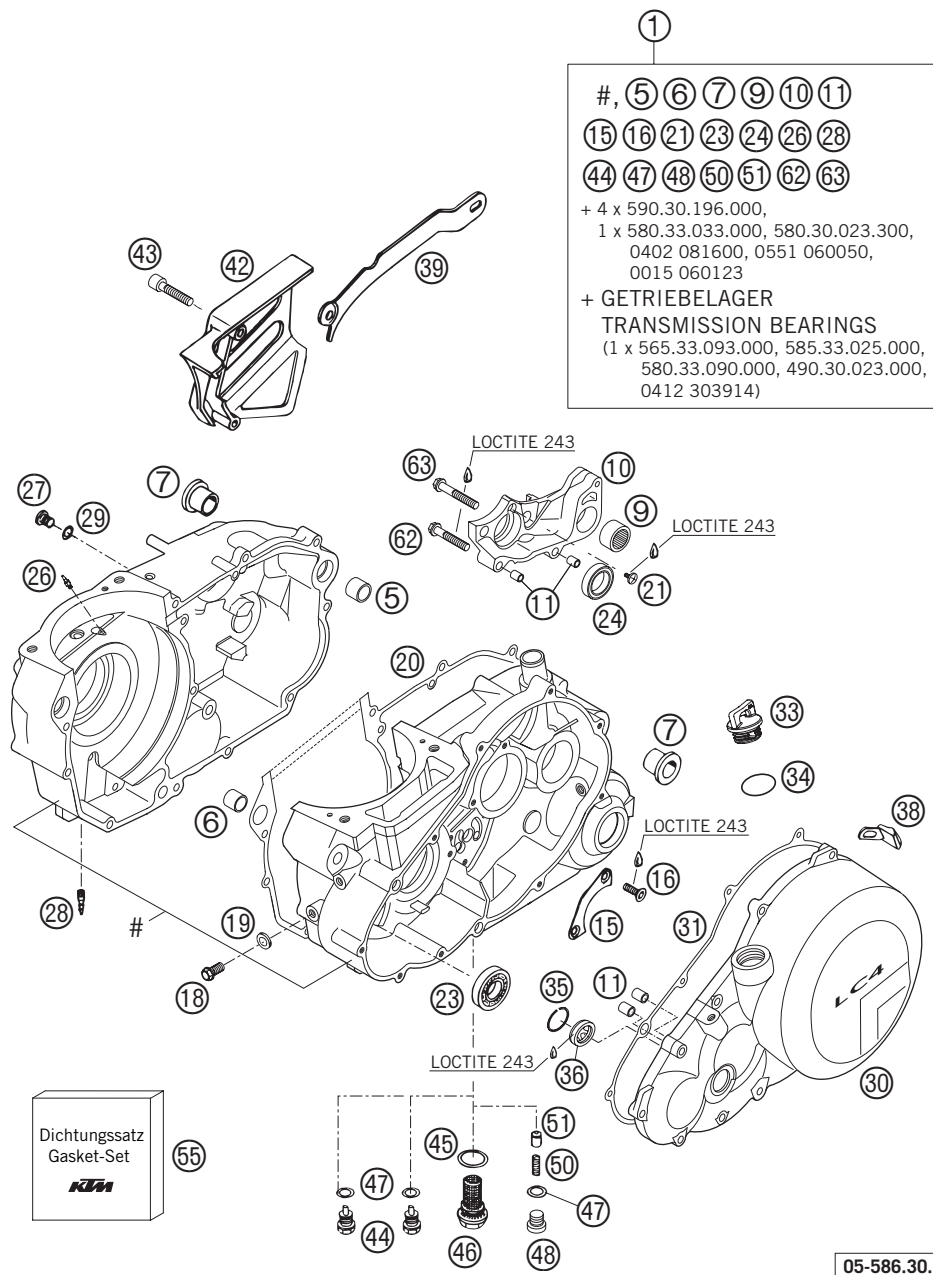

- ①
- #, ⑤ ⑥ ⑦ ⑨ ⑩ ⑪
 ⑮ ⑯ ⑰ ⑱ ⑳ ㉔ ㉕
 ㉖ ㉗ ㉘ ㉙ ㉚ ㉛ ㉜
- + 4 x 590.30.196.000,
 1 x 580.33.033.000, 580.30.023.300,
 0402 081600, 0551 060050,
 0015 060123
- + GETRIEBELAGER
 TRANSMISSION BEARINGS
 (1 x 565.33.093.000, 585.33.025.000,
 580.33.090.000, 490.30.023.000,
 0412 303914)

FIG	TEILNR/PARTNR	BEZEICHNUNG	DESCRIPTION	QTY
1	573.30.000.044/23	MOTORGEHÄUSE KPL.M.GETR.LAG.03 GRAU	ENGINE CASE CPL.W.TRAN.BEAR.03 GREY	1
5	501.30.027.000	PASSHÜLSE 19 X15,1X12	DOWEL 19 X15,1X12	1
6	510.30.026.100	PASSHÜLSE 17 X 13 X 12	DOWEL 17 X 14 X 12	1
7	501.30.010.000	GEHÄUSEBÜCHSE	CRANK CASE BUSH	2
9	580.33.097.000	NADELLAGER HK 2216	NEEDLE BEARING HK 2216	1
10	583.30.011.000	SCHALTUNGSTRÄGER LC4'94	SHIFT MECHANISM SUPPORT LC4'94	1
11	490.30.090.000	PASSHÜLSE 9,8 X 7 X 10	DOWEL 9,8 X 7 X 10	4
15	565.30.017.000	HALTEBLECH	RETAINING PLATE	1
16	0991 060166	SENKSCHR. DIN7991 M6X16 10.9	FL.HEAD SCR.DIN7991-M6X16 10.9	2
18	0015 080163	SK.BUNDSCHRAUBE M 8X16 SW=10	HH COLLAR SCREW M 8X16 WS=10	1
19	0603 082121	CU-DICHRING DIN7603- 8X12X1	SEAL RING CU DIN7603- 8X12X1	1
20	585.30.039.300	GEHÄUSEDI. POLYSTRAT 0,43MM 04	ENGI.CASE GASKET POLY. 0,43 04	1
21	0985 050103	LINSENSCHRAUBE DIN7985-M 5X10	OVAL HEAD SCR. DIN7985-M 5X10	1
23	0412 174012	ZYL.ROLLENLAGER NJ203 ECP C3	CYLIND.ROLL.NJ 203 ECP/C3 2001	1
24	0625 618050	RILLENKUGELLAGER 61805 C3	BALL BEARING 61805 C3	1
26	600.30.064.070	ÖLSPRITZDÜSE 70 M6X0,75 SW8 03	OIL JET 70 M6X0,75 WS8 03	2
27	490.30.029.000	ÖLABLASSCHR. ISK M10X1,5 SW=6	OIL DRAIN PLUG M10X1,5 AH-WS=6	1
28	491.30.450.050	DORNPROFIL LW 3	TUBE LW 3	1
29	0603 100141	CU-DICHRING DIN7603-10X14X1	COPPER GASKET DIN7603-10X14X1	1
30	583.30.101.244/23	KUPPLUNGSDECKEL KPL. GRAU 03 MIT ÖLSCHAUGLAS	CLUTCH COVER CPL. GREY 03 WITH OIL INSPECTION GLASS	1
31	585.30.025.000	KUPPLUNGSDECKELDICHUNG 2001	CLUTCH COVER GASKET 2001	1
33*	580.30.020.100	ÖLEINFÜLLSCHR. KPL. M24X3	PLUG CPL. M24X3	1
34	0770 191015	O-RING 19,00X3,00 NBR	O-RING 19,00X3,00 NBR	1
35	610.30.019.050	SICHERUNGSRING ÖLSCHAUGLAS 05	CIRCLIP OIL LEVEL GLASS 03	1
36	590.30.019.000	ÖLSCHAUGLAS G 1777 Y	OIL LEVEL GLASS G 1777 Y	1
38	583.33.041.000	ANSCHLAGGUMMI	BUMP RUBBER	1
39*	586.30.047.100	KETTENDÄMPFUNGSBLECH 17Z 05	CHAIN DAMPER SHEET 17T 05	1
42	580.30.050.700	KETTENABDECKUNG SCHWARZ '99	CHAIN COVER BLACK '99	1
43	0912 060303	ISK.SCHRAUBE DIN 912 M6X30	AH SCREW DIN0912-M 6X30	2
44	580.30.021.000	ÖLABLASSCHR.B.MAGNET M 12X1,5	OILDRAIN PLUG W.MAG. M 12X1,5	2
45	580.38.017.100	CU-DICHRING DIN7603-22X27X2	CU-SEAL RING DIN7603-22X27X2	1
46	580.38.019.100	ÖLVERSCHLUSSSCHRAUBE M22X1,5	OIL DRAIN PLUG M22X1,5	1
47	580.38.022.000	CU-DICHRING DIN7603-12X18X1,5	CU-SEAL RING DIN7603-12X18X1,5	3

* NEUTEIL / NEW PART X NACH BEDARF / AS REQUIRED

MOTORGEHÄUSE » ENGINE CASE

660 / 2005

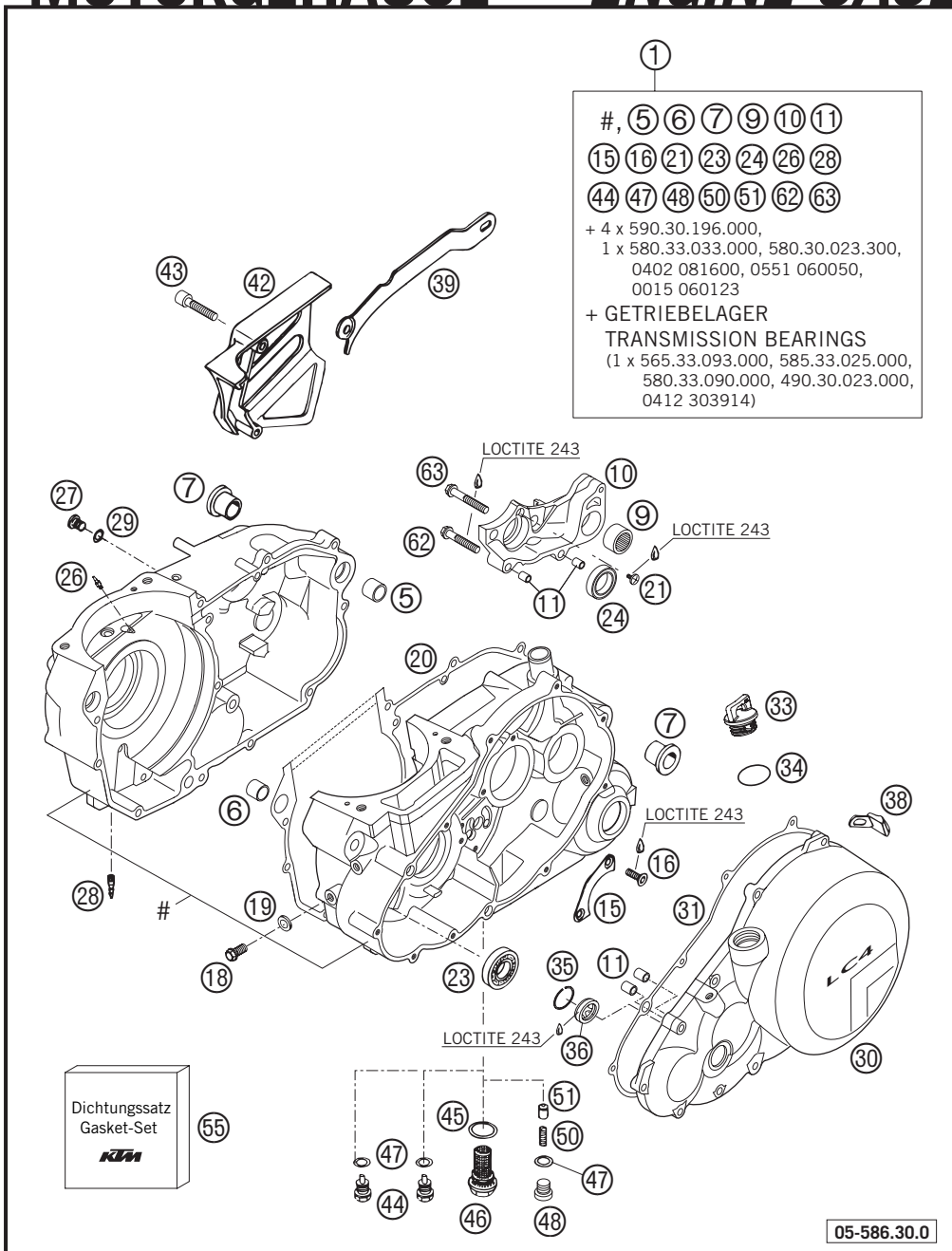
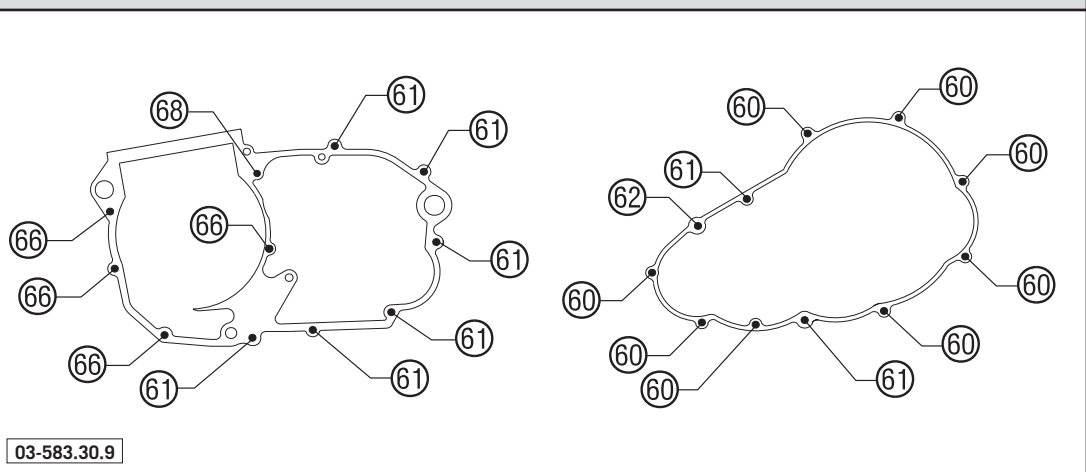

FIG	TEILNR/PARTNR	BEZEICHNUNG	DESCRIPTION	QTY
48	0908 120153	VERSCHL.SCHR. DIN0908-M12X1,5	PLUG DIN0908-M12X1,5	1
50	585.38.023.000	ÖLDRUCKFEDER 5 BAR ROT 2001	OIL PRES.SPRING 5 BAR RED 2001	1
51	580.38.028.000	VENTILKOLBEN D=10MM	VALVE PISTON D=10MM	1
55	584.30.099.200	DICHTUNGSSATZ LC4 2003	GASKET SET LC4 2003	1
60	0015 060253	SK.BUNDSCHRAUBE M 6X25 SW=8	HH COLLAR SCREW M 6X25 WS=8	8
61	0015 060303	SK.BUNDSCHRAUBE M 6X30 SW=8	HH COLLAR SCREW M 6X30 WS=8	8
62	0015 060353	SK.BUNDSCHRAUBE M 6X35 SW=8	HH COLLAR SCREW M 6X35 WS=8	2
63	0015 060403	SK.BUNDSCHRAUBE M 6X40 SW=8	HH COLLAR SCREW M 6X40 WS=8	1
66	0015 060553	SK.BUNDSCHRAUBE M 6X55 SW=8	HH COLLAR SCREW M 6X55 WS=8	4
68	0015 060653	SK.BUNDSCHRAUBE M 6X65 SW=8	HH COLLAR SCREW M 6X65 WS=8	1

05-586.30.0

* NEUTEIL / NEW PART X NACH BEDARF / AS REQUIRED



KURBELWELLE · KOLBEN » CRANKSHAFT · PISTON

625/640 / 2005

D=101mm

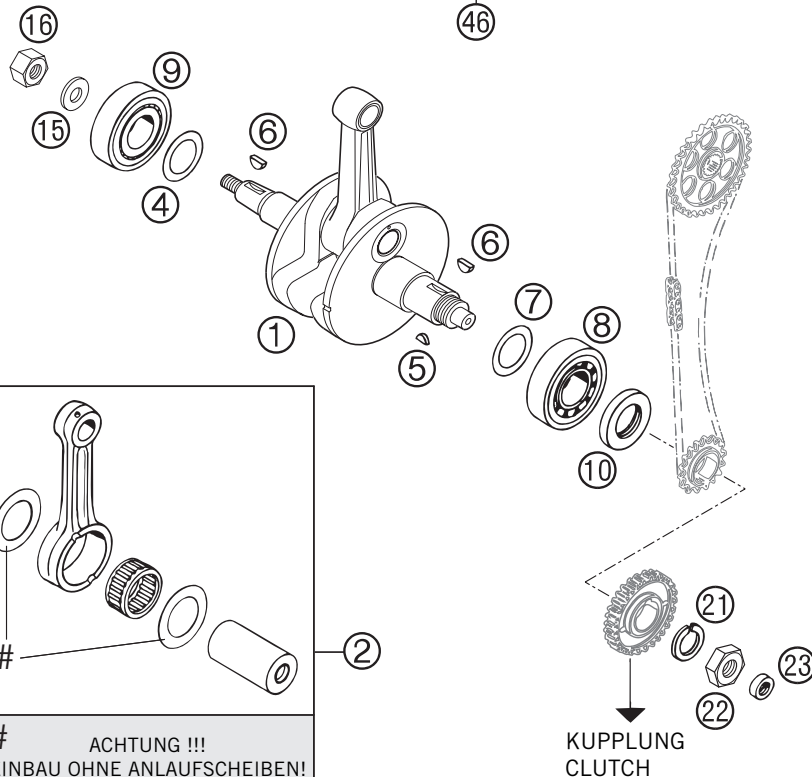
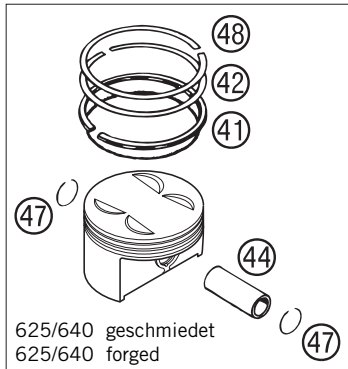

ACHTUNG !!!
EINBAU OHNE ANLAUFSCHLEIBEN!
CAUTION !!!
WITHOUT STOP DISK FITTING!

05-584.30.2

05-584.30.2

FIG	TEILNR/PARTNR	BEZEICHNUNG	DESCRIPTION	QTY
1*	584.30.018.300	KURBELWELLE KPL. LC4 HUB 78MM	CRANKSHAFT CPL. LC4 STROKE 78MM	1
2*	584.30.015.044	PLEUEL REP.SATZ LC4-E 2005 620/625/640 CCM L=141,5MM	CON.ROD REPAIR KIT 620/625/640 CCM L=141,5MM	1
4	565.30.081.000	PASSSCHEIBE 36X48X0,10	SHIM WASHER 36X48X0,10	X
4	565.30.081.100	PASSSCHEIBE 36X48X0,15	SHIM WASHER 36X48X0,15	X
4	565.30.081.300	PASSSCHEIBE 36X48X0,30	SHIM WASHER 36X48X0,30	X
5	0888 030050	SCHEIBENFEDER DIN6888-3X5X13	WOODRUFF KEY DIN6888-3X5X13	1
6	6 946 005	SCHEIBENFEDER 5X6,5 GEHÄRTET	WOODRUFF KEY 5X6,5 HARDENED	2
7	560.30.081.000	PASSSCHEIBE 30,5X45X0,10	THRUST WASHER 30,5X45X0,10	X
7	560.30.081.100	PASSSCHEIBE 30,7X47X0,15	THRUST WASHER 30,7X47X0,15	X
7	560.30.081.200	PASSSCHEIBE 30,5X45X0,30	THRUST WASHER 30,5X45X0,30	X
8	580.30.082.000	ZYLINDERROLLENLAGER NJ 306 C3	CYL.ROLLER BEARING NJ 306 C3	1
9	565.30.123.000	ZYL.ROLLENLAGER NJ 207 ECP C3	CYL. ROLLER BEARING NJ 207 ECP	1
10	0760 304772	WELLENDICHTR.30X47X7 BSL VITON	SH.SEAL RING 30X47X7 BSL VITON	1
15	583.30.095.000	STAHSCHLEIBE 16 X 30 X 3	STEEL WASHER 16 X 30 X 3	1
16	584.30.028.000	SK-MUTTER M16X1,25 LINKS	HEX NUT M16X1,25 L/S	1
21	580.30.019.000	SPERRKANTRING VSK 20	LOCKING RING VSK 20	1
22	0936 200155	SK.MUTTER DIN0936-M20X1,5	HEXAGON NUT DIN0936-M20X1,5	1
23	0760 122270	WELLENDICHTRING 12 X 22 X 7 B	SHAFT SEAL RING 12 X 22 X 7 B	1
41	583.30.031.300	ÖLABSTREIFRING 101X2,5	OIL SCRAPER RING 101X2,5	1
42	583.30.932.100	MINUTENRING 101X1,25	TAP.COMPR.PISTON RING 101X1,25	1
44	583.30.833.000	KOLBENBOLZEN 22 X 13 X 60	PISTON PIN 22 X 13 X 60	1
46	584.30.007.100/ I	KOLBEN I KPL. D=101 ELKO 03	PISTON I CPL. D=101 ELKO 03	1
46	584.30.007.100/ II	KOLBEN II KPL. D=101 ELKO 03	PISTON II CPL. D=101 ELKO 03	1
47	584.30.074.000	DRAHTSPRENGRING 22 X 1,6	CIRCLIP 22 X 1,6	2
48	584.30.032.000	L-RING 101X93,5X1,5 2000	L-RING 101X93,5X1,5 2000	1

* NEUTEIL / NEW PART X NACH BEDARF / AS REQUIRED

KURBELWELLE · KOLBEN » CRANKSHAFT · PISTON

660 / 2005

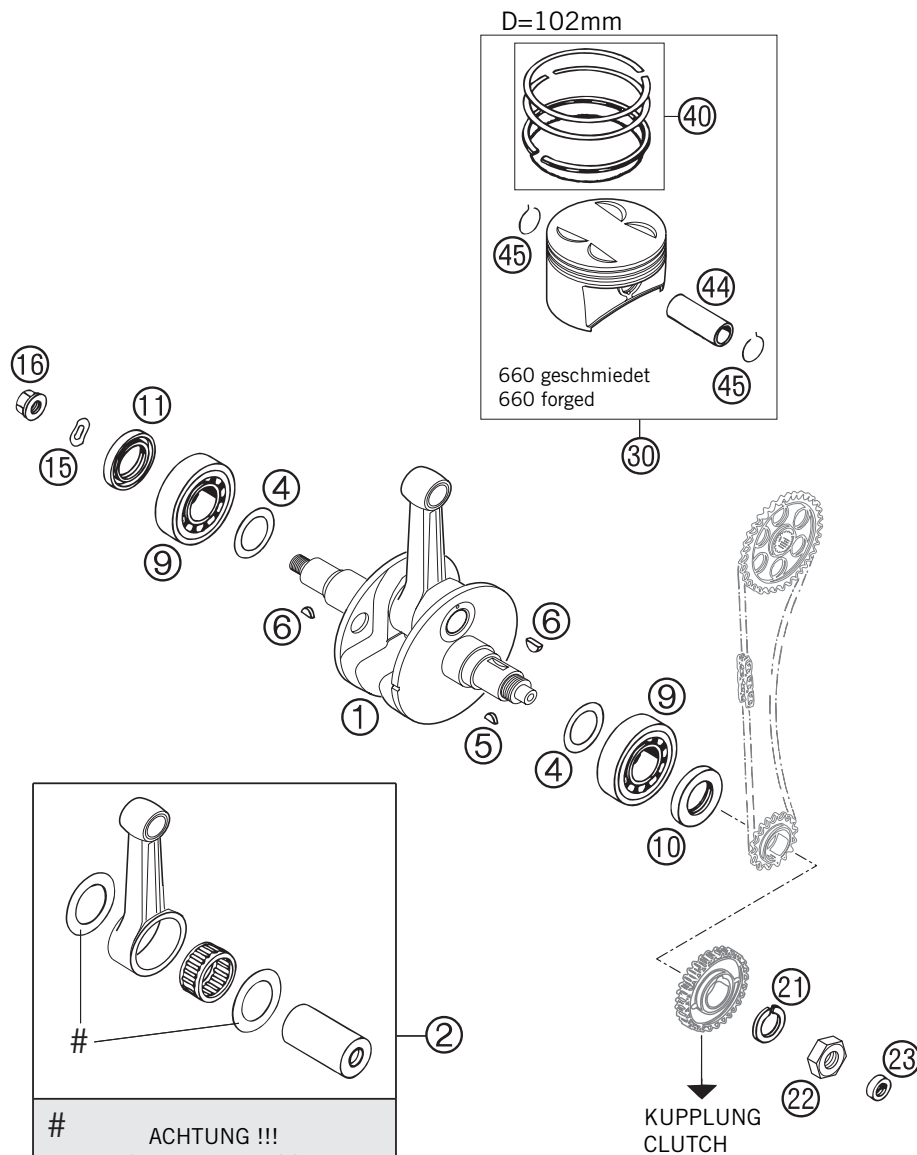

ACHTUNG !!!
EINBAU OHNE ANLAUFSCHLEIBEN!
CAUTION !!!
WITHOUT STOP DISK FITTING!

05-586.30.3

FIG	TEILNR/PARTNR	BEZEICHNUNG	DESCRIPTION	QTY
1*	573.30.018.100	KURBELWELLE KPL. LC4 660 05	CRANKSHAFT CPL. LC4 660 05	1
2*	585.30.015.144	PLEUELREPERATURSATZ LC4 2005 L=141,5MM	CONNECT. ROD REPAIR SET LC4 05 L=141,5MM	1
4	565.30.081.000	PASSSCHEIBE 36X48X0,10	SHIM WASHER 36X48X0,10	X
4	565.30.081.100	PASSSCHEIBE 36X48X0,15	SHIM WASHER 36X48X0,15	X
4	565.30.081.300	PASSSCHEIBE 36X48X0,30	SHIM WASHER 36X48X0,30	X
5	0888 030050	SCHEIBENFEDER DIN6888-3X5X13	WOODRUFF KEY DIN6888-3X5X13	1
6	6 946 005	SCHEIBENFEDER 5X6,5 GEHÄRTET	WOODRUFF KEY 5X6,5 HARDED	2
9	565.30.123.000	ZYL.ROLLENLAGER NJ 207 ECP C3	CYL. ROLLER BEARING NJ 207 ECP	2
10	0760 304071	WELLENDICHTRING 30X40X7 BSL	SHAFT SEAL RING 30X40X7 BSL	1
11	0760 304772	WELLENDICHTR.30X47X7 BSL VITON	SH.SEAL RING 30X47X7 BSL VITON	1
15	0137 120000	FEDERSCHLEIBE DIN0137-B12	SPRING WASHER DIN0137-B12	1
16	510.30.028.100	BUNDMUTTER M12X1 LINKS SW=17	COLLAR NUT M12X1 LEFT WS=17	1
21	580.30.019.000	SPERRKANTRING VSK 20	LOCKING RING VSK 20	1
22	0936 200155	SK.MUTTER DIN0936-M20X1,5	HEXAGON NUT DIN0936-M20X1,5	1
23	0760 122270	WELLENDICHTRING 12 X 22 X 7 B	SHAFT SEAL RING 12 X 22 X 7 B	1
30	585.30.007.300/ I	KOLBEN I KPL. D=102MM 03	PISTON I CPL. D=102MM 03	1
30	585.30.007.300/ II	KOLBEN II KPL. D=102MM 03	PISTON II CPL. D=102MM 03	1
40	585.30.031.144	KOLBENRINGSATZ ELKO 660 RALLYE	PISTONRING SET ELKO 660 RALLYE	1
44	583.30.833.000	KOLBENBOLZEN 22 X 13 X 60	PISTON PIN 22 X 13 X 60	1
45	584.30.074.000	DRAHTSPRENGRING 22 X 1,6	CIRCLIP 22 X 1,6	2

05-586.30.3

* NEUTEIL / NEW PART X NACH BEDARF / AS REQUIRED

AUSGLEICHSWELLE » *BALANCER SHAFT*

625-660 / 2005

FIG	TEILNR/PARTNR	BEZEICHNUNG	DESCRIPTION	QTY
1	573.30.057.044	AUSGLEICHSWELLE KPL. STAHL	BALANCER SHAFT CPL. STEEL	1
4	0625 160040	RILLENKUGELLAGER TM 16004 C3	GROOVED BALL BEAR. TM 16004 C3	1
5	0412 174012	ZYL.ROLLENLAGER NJ203 ECP C3	CYLIND.ROLL.NJ 203 ECP/C3 2001	1

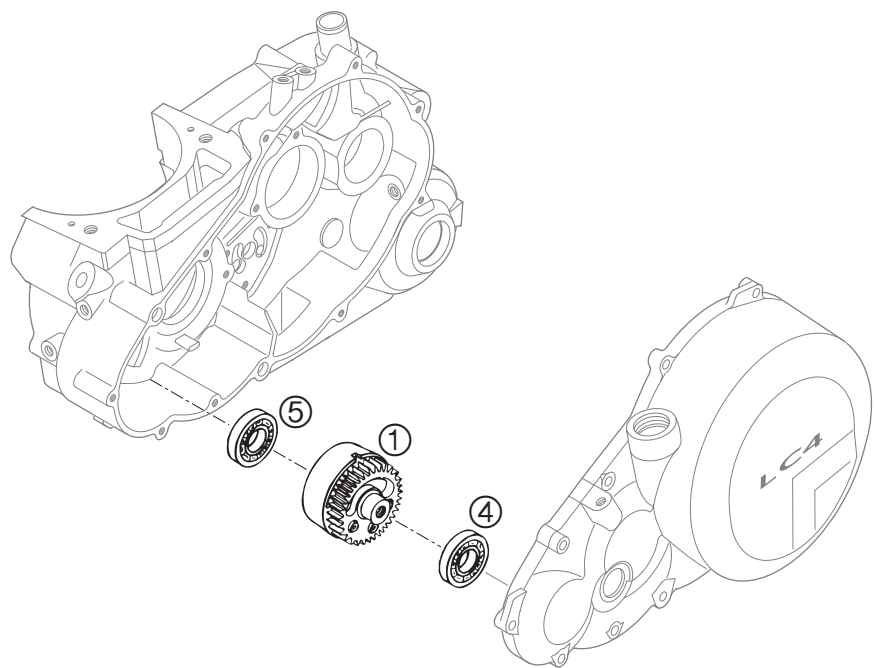

05-584.30.4

04-583.30.4

* NEUTEIL / NEW PART X NACH BEDARF / AS REQUIRED

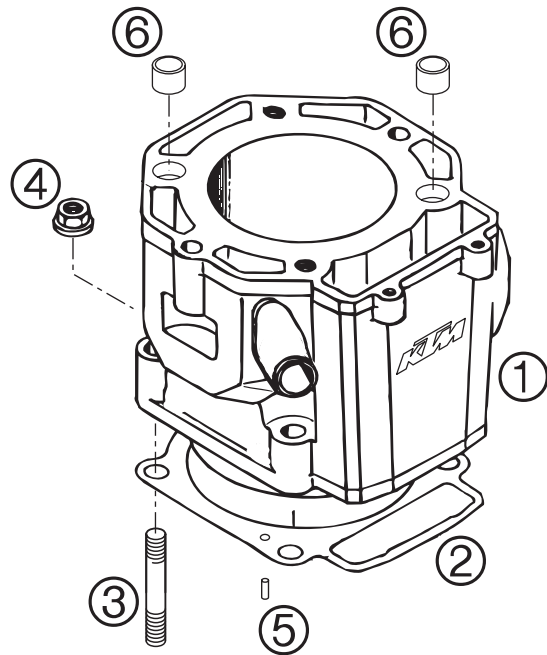

FIG	TEILNR/PARTNR	BEZEICHNUNG	DESCRIPTION	QTY
1	584.30.005.100/23	ZYLINDER D=101 KOKILLEN. 03	CYLINDER D=101 DIECASTING 03	1
2*	586.30.035.100	ZYLINDERFUSSDICHTUNG 0,5MM 05	CYL. BASE GASKET 0,5MM 05	1
3	0835 100456	STIFTSCHRAUBE DIN0835-M10X45 VERZINKT	STUD DIN0835-M10X45 ZINC COATED	4
4	0331 100003	BUNDMUTTER DIN6923-M10 SW=15	COLLAR NUT DIN6923-M10 WS=15	4
5	0402 040980	NADELROLLE DIN5402 NRB 4X9,8	NEEDLE ROL. DIN5402 NRB 4X9,8	2
6	583.30.023.000	PASSHÜLSE 17 X 14 X 9,5	DOWEL 17 X 14 X 9,5	2

05-584.30.5

05-584.30.5

* NEUTEIL / NEW PART

X NACH BEDARF / AS REQUIRED

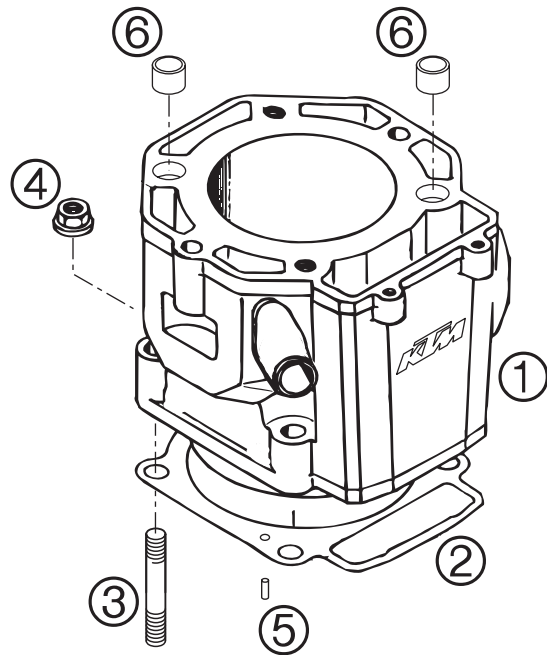

FIG	TEILNR/PARTNR	BEZEICHNUNG	DESCRIPTION	QTY
1	586.30.005.000/23	ZYLINDER D=102 KOKIL. SM 2003	CYLINDER D=102 DIECAST. SM 03	1
2*	586.30.035.100	ZYLINDERFUSSDICHTUNG 0,5MM 05	CYL. BASE GASKET 0,5MM 05	1
3	585.30.043.000	STEBOLZEN M 10X75	STUD M10X75	4
4	0331 100003	BUNDMUTTER DIN6923-M10 SW=15	COLLAR NUT DIN6923-M10 WS=15	4
5	0402 040980	NADELROLLE DIN5402 NRB 4X9,8	NEEDLE ROL. DIN5402 NRB 4X9,8	2
6	583.30.023.000	PASSHÜLSE 17 X 14 X 9,5	DOWEL 17 X 14 X 9,5	2

05-584.30.5

05-586.30.5

* NEUTEIL / NEW PART X NACH BEDARF / AS REQUIRED

ZYLINDERKOPF » CYLINDER HEAD

625/640 / 2005

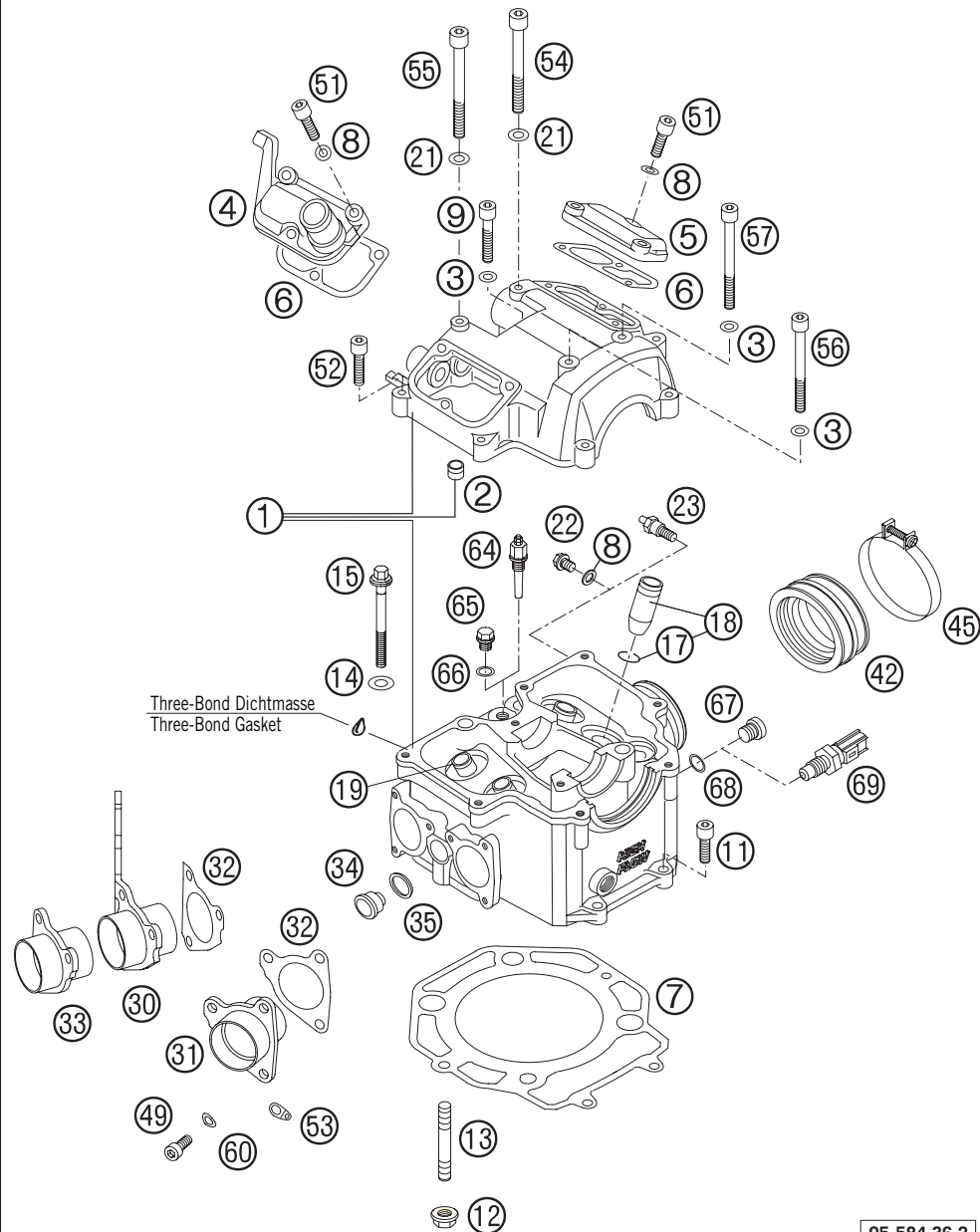

05-584.36.2

FIG	TEILNR/PARTNR	BEZEICHNUNG	DESCRIPTION	QTY
1	584.36.020.200/23	ZYLINDERK. KPL. LC4/SXC SLS 04	CYL. HEAD CPL. LC4/SXC SAS 04	1
2	585.30.090.000	PASSBÜCHSE 9,8X7,2X10	DOWEL BUSHING 9,8X7,2X10	1
3	580.36.065.100	CU-DICHRING 6 X 10 X 2	CU-SEAL RING 6 X 10 X 2	3
4	580.36.152.600	VENTILDECKEL VORNE '99	VALVE COVER FRONT '99	1
5	580.36.052.000	VENTILDECKEL HINTEN	VALVE COVER REAR	1
6	580.36.053.000	VENTILDECKELDICHUNG	VALVE COVER GASKET	2
7	583.30.036.000	ZYLINDERKOPFDICHUNG 101,3 MM 612/620/625/640 LC4	CYLINDER HEAD GASKET 101,3 MM 612/620/625/640 LC4	1
8	0603 061001	CU-DICHRING DIN7603-6X10X1	CU-SEAL RING DIN7603-6X10X1	7
9	0912 060353	ISK.SCHRAUBE DIN 912 M6X35	AH SCREW DIN912-M 6X35	1
11	0912 060253	ISK.SCHRAUBE DIN 912 M6X25	AH SCREW DIN912-M 6X25	2
12	490.30.028.000	BUNDMUTTER M8	COLLAR NUT M8 - 8MM HIGH	2
13	543.30.043.000	STIFTSCHRAUBE DIN0835-M 8X40 600/612/620/625/640 LC4	STUD DIN0835-M 8X40 600/612/620/625/640 LC4	2
14*	0125 100003	UNTERLEGSCHLEIBE DIN 125 A 10,5	WASHER DIN0125-A10,5	4
15	580.36.099.100	BUNDSCHRAUBE M10X80 SW=13 10.9	COLLAR SCREW M10X80 WS=13 10.9	4
17	0993 012000	SPRENGRING DIN7993-RW12	CIRCLIP DIN7993-RW12	4
18	580.36.026.644	VENTILFÜHRUNG EINLASS KPL.	VALVE GUIDE INTAKE CPL.	2
19	580.36.126.644	VENTILFÜHRUNG AUSLASS KPL.	VALVE GUIDE EXHAUST CPL.	2
21	0603 070122	CU-DICHRING DIN7603- 7X12X2	CU-SEAL RING DIN7603- 7X12X2	2
22	0015 060083	SK.BUNDSCHRAUBE M 6X8 SW=8	HH COLLAR SCREW M 6X8 WS=8	1
23	583.36.020.190	UNTERDRUCKANSCHLUSS M6X1 '97 SEKUNDÄRLUFTSYSTEM	VACUUM CONECTION M6X1 '97 SECONDARY AIR SYSTEM	1
30	584.36.039.100	AUSPUFFFLANSCH KPL RE. SLS 04	EXHAUST FLANGE CPL. R/S SAS 04	1
31	580.36.140.100	AUSPUFFFLANSCH LINKS	EXHAUST FLANGE L/S	1
32	580.36.041.000	AUSPUFFFLANSCHDICHUNG	EXHAUST FLANGE GASKET	2
33	580.36.040.100	AUSPUFFFLANSCH RECHTS 04 OHNE SLS	EXHAUST FLANGE R/S 04 WITHOUT SAS	1
34	583.36.024.000	VERSCHLUSSPFROPFEN FÜR SLS	PLUG SAS BORE	1
35	584.36.054.000	CU-FÜLLRING 12 X 16 X 2	CU-SEAL RING 12 X 16 X 2	1
42	584.36.044.000	GUMMIMUFFE FÜR MIKUNI VERGASER 640 LC4	INTAKE BOOT FOR MIKUNI CARBU. 640 LC4	1
42	585.36.044.000	GUMMIMUFFE RALLYE 2001 625 LC4	INTAKE BOOT RALLYE 2001 625 LC4	1
45	565.30.061.000	SCHELLE SM12/A60	CLAMP SM12/A60	2

05-584.36.2

* NEUTEIL / NEW PART X NACH BEDARF / AS REQUIRED

ZYLINDERKOPF » CYLINDER HEAD

625/640 / 2005

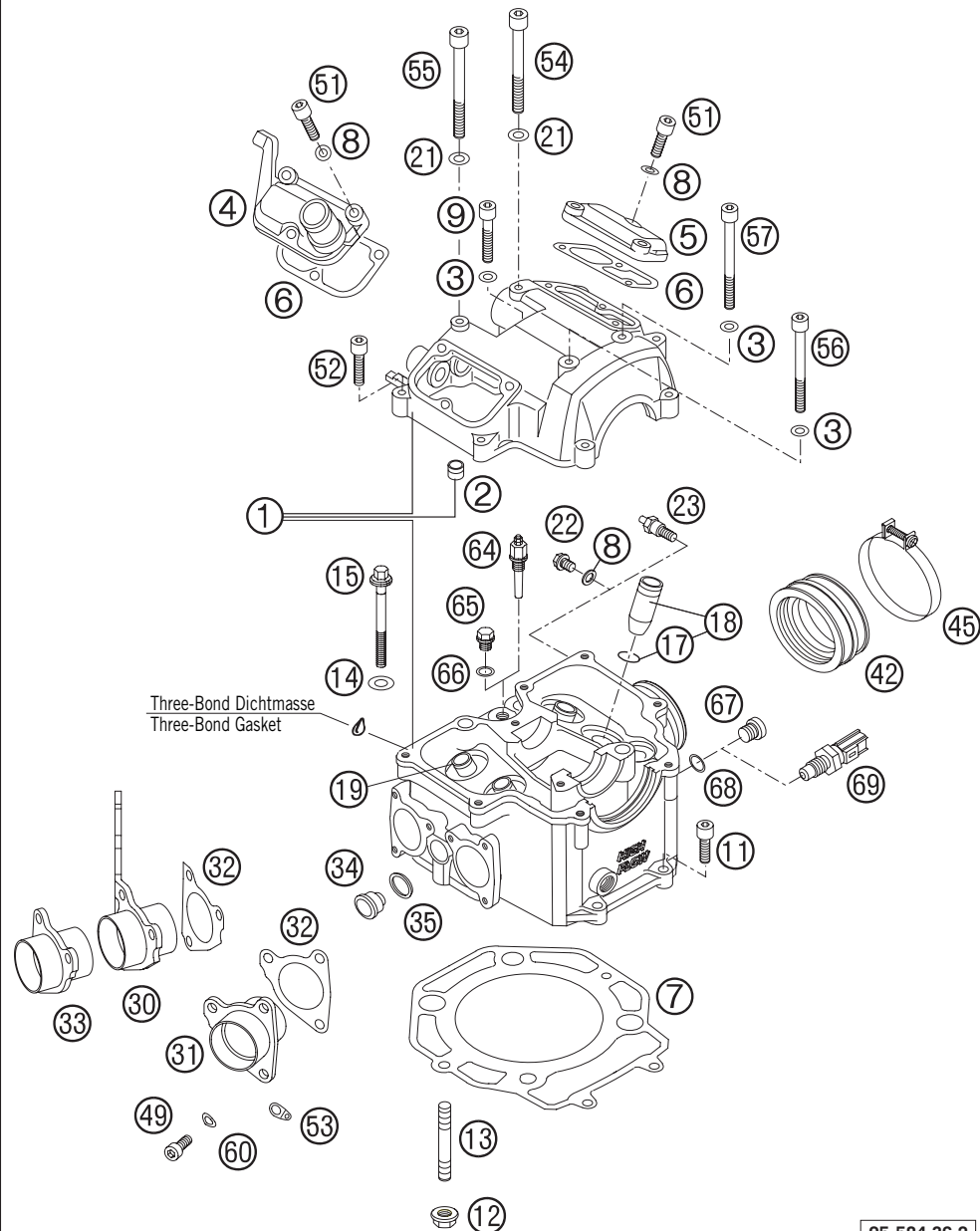

FIG	TEILNR/PARTNR	BEZEICHNUNG	DESCRIPTION	QTY
		640 LC4	640 LC4	
45	590.30.061.000	SHELLE D=56MM B=9MM M4X25 625 LC4	CLAMP D=56MM B=9MM M4X25 625 LC4	1
49	0912 060163	ISK.SCHRAUBE DIN 912 M6X16	AH SCREW DIN0912-M 6X16	6
51	0912 060203	ISK.SCHRAUBE DIN 912 M6X20	AH SCREW DIN0912-M 6X20	6
52	0912 060253	ISK.SCHRAUBE DIN 912 M6X25	AH SCREW DIN0912-M 6X25	5
53	510.05.074.000	FEDERLASCHE	RETAINING PLATE	4
54	0912 070553	ISK.SCHR. DIN0912-M 7X55 12.9	AH SCREW DIN0912-M 7X55 12.9	1
55	0912 070603	ISK.SCHR. DIN0912-M 7X60 12.9	AH SCREW DIN0912-M 7X60 12.9	1
56	0912 060653	ISK.SCHRAUBE DIN 912 M6X65	AH SCREW DIN0912-M 6X65	1
57	0912 060703	ISK.SCHRAUBE DIN 912 M6X70	AH SCREW DIN0912-M 6X70	1
60	0137 060003	FEDERSCHEIBE DIN 137 B 6	SPRING WASHER DIN0137-B 6	6
64	420.11.252.000	TEMPERATURSCHALTER VDO DUKE	TEMPERATURE SWITCH VDO DUKE	1
65	0910 100003	VERSCHL.SCHR.DIN0910-M 10X1 LC4, LC4 SM, ADVENTURE	PLUG DIN0910-M 10X1 LC4, LC4 SM, ADVENTURE	1
66	0603 100141	CU-DICHTRING DIN7603-10X14X1	COPPER GASKET DIN7603-10X14X1	1
67	0908 120153	VERSCHL.SCHR. DIN0908-M12X1,5 DUKE, 625 LC4	PLUG DIN0908-M12X1,5 DUKE, 625 LC4	1
68	0770 100020	O-RING 10,00X2,00 SILICON	O-RING 10,00X2,00 SILICONE	1
69	600.11.252.000	TEMPERATURSENSOR WASSER LC8 02 LC4, LC4 SM, ADVENTURE	TEMPERAT.-SENSOR WATER LC8 02 LC4, LC4 SM, ADVENTURE	1

05-584.36.2

05-584.36.2

* NEUTEIL / NEW PART X NACH BEDARF / AS REQUIRED

ZYLINDERKOPF » CYLINDER HEAD

660 / 2005

G = 660 ccm

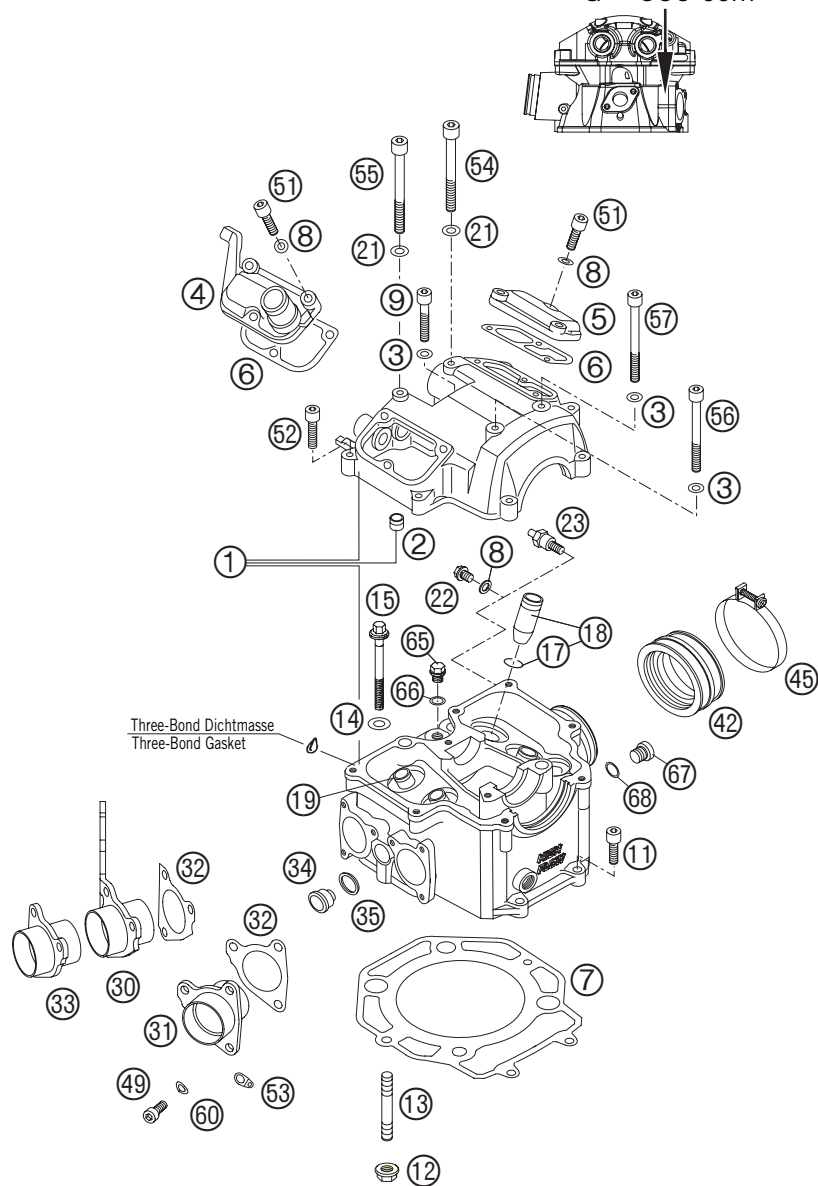

05-586.36.2

FIG	TEILNR/PARTNR	BEZEICHNUNG	DESCRIPTION	QTY
1	586.36.020.100/23	ZYLINDERKOPF KPL. SM SLS 04	CYLINDER HEAD CPL. SM SAS 04	1
2	585.30.090.000	PASSBÜCHSE 9,8X7,2X10	DOWEL BUSHING 9,8X7,2X10	1
3	580.36.065.100	CU-DICHTRING 6 X 10 X 2	CU-SEAL RING 6 X 10 X 2	3
4	580.36.152.600	VENTILDECKEL VORNE '99	VALVE COVER FRONT '99	1
5	580.36.052.000	VENTILDECKEL HINTEN	VALVE COVER REAR	1
6	580.36.053.000	VENTILDECKELDICHUNG	VALVE COVER GASKET	2
7	585.30.036.000	ZYLINDERKOPFDICHTUNG 102,3MM	CYLINDER HEAD GASKET 102,3MM	1
8	0603 061001	CU-DICHTRING DIN7603-6X10X1	CU-SEAL RING DIN7603-6X10X1	7
9	0912 060353	ISK.SCHRAUBE DIN 912 M6X35	AH SCREW DIN0912-M 6X35	1
11	0912 060253	ISK.SCHRAUBE DIN 912 M6X25	AH SCREW DIN0912-M 6X25	2
12	490.30.028.000	BUNDMUTTER M8	COLLAR NUT M8 - 8MM HIGH	2
13	543.30.043.000	STIFTSCHRAUBE DIN0835-M 8X40 600/612/620/625/640/660 LC4	STUD DIN0835-M 8X40 600/612/620/625/640/660 LC4	2
14	0125 100003	UNTERLEGSCHIBE DIN 125 A 10,5	WASHER DIN0125-A10,5	4
15	580.36.099.100	BUNDSCHRAUBE M10X80 SW=13 10.9	COLLAR SCREW M10X80 WS=13 10.9	4
17	0993 012000	SPRENGRING DIN7993-RW12	CIRCLIP DIN7993-RW12	4
18	580.36.026.644	VENTILFÜHRUNG EINLASS KPL.	VALVE GUIDE INTAKE CPL.	2
19	580.36.126.644	VENTILFÜHRUNG AUSLASS KPL.	VALVE GUIDE EXHAUST CPL.	2
21	0603 070122	CU-DICHTRING DIN7603- 7X12X2	CU-SEAL RING DIN7603- 7X12X2	2
22	0015 060083	SK.BUNDSCHRAUBE M 6X8 SW=8	HH COLLAR SCREW M 6X8 WS=8	X
23	583.36.020.190	UNTERDRUCKANSCHLUSS M6X1 '97 SEKUNDÄRLUFTSYSTEM	VACUUM CONECTION M6X1 '97 SECONDARY AIR SYSTEM	1
30	584.36.039.100	AUSPUFFFLANSCH KPL RE. SLS 04	EXHAUST FLANGE CPL. R/S SAS 04	1
31	580.36.140.100	AUSPUFFFLANSCH LINKS	EXHAUST FLANGE L/S	1
32	580.36.041.000	AUSPUFFFLANSCHDICHTUNG	EXHAUST FLANGE GASKET	2
33	580.36.040.100	AUSPUFFFLANSCH RECHTS 04 OHNE SLS	EXHAUST FLANGE R/S 04 WITHOUT SAS	X
34	583.36.024.000	VERSCHLUSSPFROPFEN FÜR SLS	PLUG SAS BORE	X
35	584.36.054.000	CU-FÜLLRING 12 X 16 X 2	CU-SEAL RING 12 X 16 X 2	1
42	585.36.044.000	GUMMIMUFFE RALLYE 2001	INTAKE BOOT RALLYE 2001	1
45	590.30.061.000	SCHELLE D=56MM B=9MM M4X25	CLAMP D=56MM B=9MM M4X25	2
49	0912 060163	ISK.SCHRAUBE DIN 912 M6X16	AH SCREW DIN0912-M 6X16	6
51	0912 060203	ISK.SCHRAUBE DIN 912 M6X20	AH SCREW DIN0912-M 6X20	6
52	0912 060253	ISK.SCHRAUBE DIN 912 M6X25	AH SCREW DIN0912-M 6X25	6
53	510.05.074.000	FEDERLASCHE	RETAINING PLATE	4

05-586.36.2

* NEUTEIL / NEW PART X NACH BEDARF / AS REQUIRED

ZYLINDERKOPF » CYLINDER HEAD

660 / 2005

G = 660 ccm

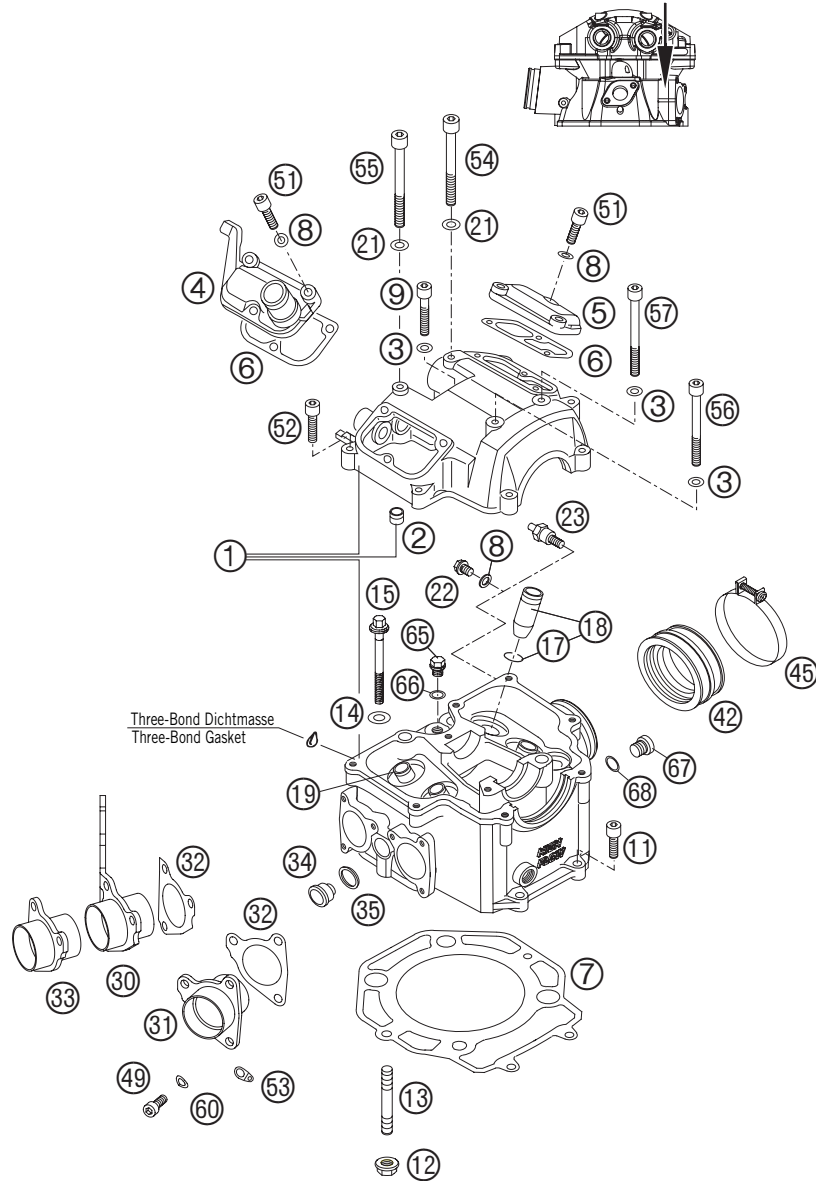

05-586.36.2

05-586.36.2

FIG	TEILNR/PARTNR	BEZEICHNUNG	DESCRIPTION	QTY
54	0912 070553	ISK.SCHR. DIN0912-M 7X55 12.9	AH SCREW DIN0912-M 7X55 12.9	1
55	0912 070603	ISK.SCHR. DIN0912-M 7X60 12.9	AH SCREW DIN0912-M 7X60 12.9	1
56	0912 060653	ISK.SCHRAUBE DIN 912 M6X65	AH SCREW DIN0912-M 6X65	1
57	0912 060703	ISK.SCHRAUBE DIN 912 M6X70	AH SCREW DIN0912-M 6X70	1
60	0137 060003	FEDERSCHEIBE DIN 137 B 6	SPRING WASHER DIN0137-B 6	6
65	0910 100003	VERSCHL.SCHR.DIN0910-M 10X1	PLUG DIN0910-M 10X1	1
66	0603 100141	CU-DICHTRING DIN7603-10X14X1	COPPER GASKET DIN7603-10X14X1	1
67	0908 120153	VERSCHL.SCHR. DIN0908-M12X1,5	PLUG DIN0908-M12X1,5	1
68	0770 100020	O-RING 10,00X2,00 SILICON	O-RING 10,00X2,00 SILICONE	1

* NEUTEIL / NEW PART X NACH BEDARF / AS REQUIRED

SEKUNDÄRLUFTSYSTEM » SECONDARY AIR SYSTEM

625/640 / 2005

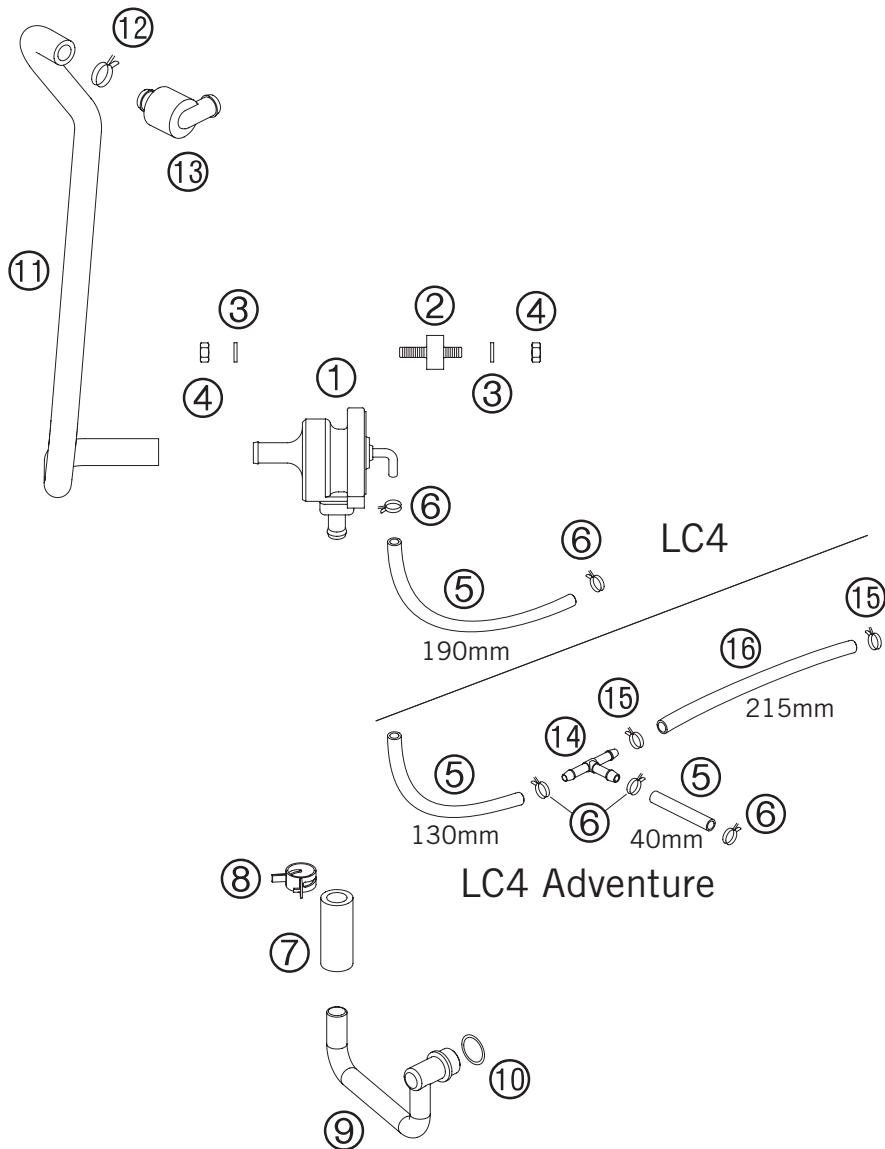
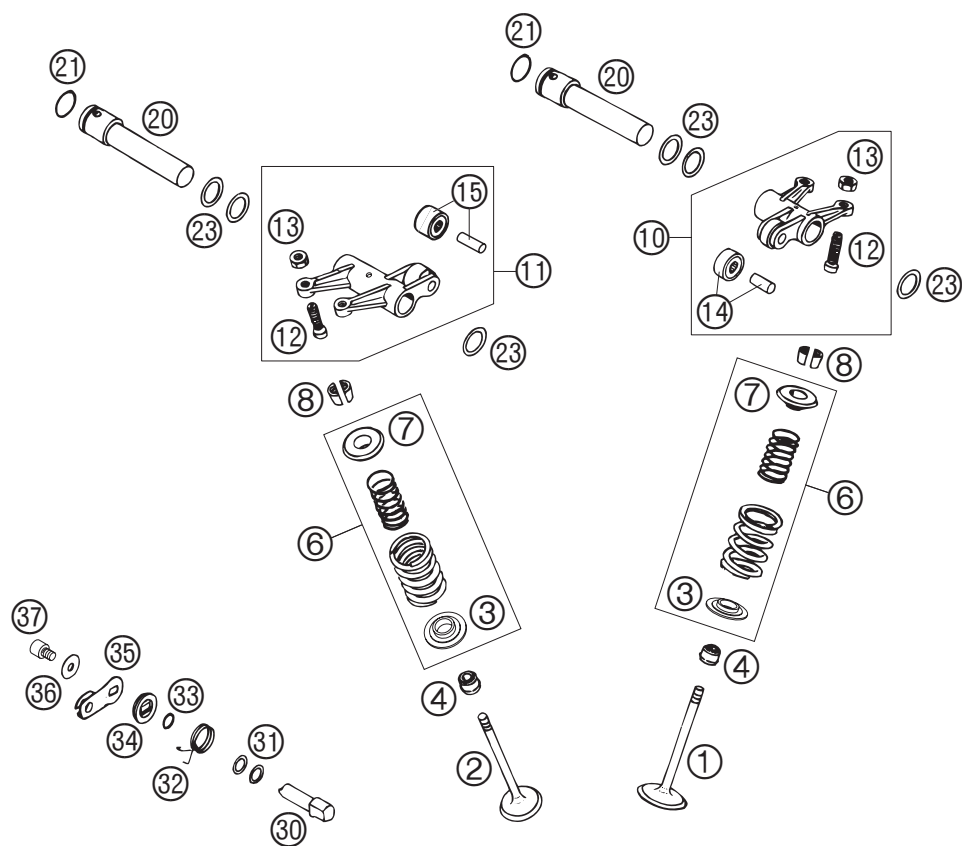

FIG	TEILNR/PARTNR	BEZEICHNUNG	DESCRIPTION	QTY
1	584.05.026.100	SLS-VENTIL 04	SAS-VALVE 04	1
2	584.05.021.000	SILENTBLOCK 20X10 M6X10/M6X16	SILENTBLOCK 20X10 M6X10/M6X16	2
3	0797 060003	ZAHNSCHEIBE DIN6797-J 6,4	TOOTH LOCK WASH. DIN6797-A 6,4	4
4	0934 060003	SK.MUTTER DIN 934 M6	HEXAGON NUT DIN0934-M 6	4
5	584.05.029.001	ND-SCHLAUCH 4X9 PER METER	ND-HOSE 4X9 PER METER	1
6	450.31.005.000	YDNAC-KLAMMER BENZINSCHL.(8MM)	YDNAC-CLAMP FUEL HOSE (8MM)	2(4)
7	584.05.019.000	SCHLAUCH SLS VENT. U. VERB-ROH	HOSE SAS-VALVE - CONNECT. TUBE	1
8*	000.49.170.121	FEDERBANDSCHELLE STD DN17	CLAMP STD DN17	2
9	584.05.027.100	SLS-VERBINUNGSROHR 04	CONNECTING TUBE SAS 04	1
10	584.36.054.000	CU-FÜLLRING 12 X 16 X 2	CU-SEAL RING 12 X 16 X 2	1
11	584.05.020.000	FORMSCHLAUCH SLS 04	PREFORMED HOSE SAS 04	1
12	584.31.082.100	YDNAC-KLAMMER 10173 (16MM) '98	YDNAC-CLAMP 10173 (16MM) '98	1
13	584.31.070.000	LUFTFILTER LC4 FÜR EPC 98	AIR FILTER LC4 '98	1
14	584.05.030.000	T-STÜCK 5MM TS5 FÜR ADVENTURE	T-CONNECTION 5MM TS5 FOR ADV.	1
15	580.07.117.000	YDNAC-KLAMMER 10107 10MM	YDNAC-CLAMP 10107 10MM	2
16	582.05.035.001	GEWEBESCHLAUCH 5,5X10,5MM	HOSE 6X10 PER METER	1

05-584.31.2

05-584.31.2

* NEUTEIL / NEW PART X NACH BEDARF / AS REQUIRED



05-584.36.3

FIG	TEILNR/PARTNR	BEZEICHNUNG	DESCRIPTION	QTY
1	580.36.030.000	EINLASSVENTIL D=36 MM	INTAKE VALVE D=36 MM	2
2	585.36.031.000	AUSLASSVENTIL D=32 MM 2001	EXHAUST VALVE D=32 MM 2001	2
3	573.36.036.000	VENTILFEDERAUFLAGE GESTUFT	VALVE SPRING HOLDER GRADED	4
4	580.36.028.000	VENTILSCHAFTDICHTUNG	VALVE-STEAM SEALING	4
6	585.36.029.044	VENTILFEDERSATZ RALLYE 2001	VALVE SPRING KIT RALLYE 2001	4
7	580.36.032.700	VENTILFEDERTELLER ALU '95	VALVE-SPRING RETAINER ALU '95	4
8	580.36.033.000	VENTILKEGELSTÜCK MK7	VALVE COLLET MK7	8
10*	585.36.060.144	KIPPHEBEL EINLASS KPL. 2005	ROCKER ARM INTAKE CPL. 2005	1
11*	585.36.061.144	KIPPHEBEL AUSLASS KPL. 2005	ROCKER ARM EXHAUST CPL. 2005	1
12	580.36.062.600	EINSTELLSCHRAUBE KPL. M 7X0,75	ADJUSTMENT SCREW CPL. M 7X0,75	4
13	0934 070756	SK.MUTTER DIN0934-M 7X0,75	HEXAGON NUT DIN0934-M 7X0,75	4
14	580.36.061.090	KIPPHEBELROLLE KPL. EINLASS	ROCKER ARM ROLLER CPL. INTAKE	1
15	583.36.061.090	KIPPHEBELROLLE KPL. AUSLASS	ROCKER ARM ROLLER CPL. EXHAUST	1
20	585.36.056.100	KIPPHEBELWELLE L=96MM 7,2MM	ROCKER ARM SHAFT L=96MM 7,2MM	2
21	580.36.095.000	O-RING 15,08X2,62 NBR 70	O-RING 15,08 X 2,62 NBR 70	2
23	0988 162202	PASSSCHEIBE DIN0988-16X22X0,20	THRUST WASH. DIN0988-16X22X0,20	X
23	0988 162205	PASSSCHEIBE DIN0988-16X22X0,5	THRUST WASH. DIN0988-16X22X0,5	X
23	0988 162210	PASSSCHEIBE DIN0988-16X22X1	THRUST WASHER DIN0988-16X22X1	X
30	580.36.050.100	DEKO-WELLE	DECOMPRESSION SHAFT	1
31	543.34.015.000	SCHEIBE 10X14X0,5 STAHL	WASHER 10X14X0,5 STEEL	X
31	543.34.015.100	SCHEIBE 10X14X0,3 STAHL	WASHER 10X14X0,3 STEEL	X
31	543.34.015.200	SCHEIBE 10X14X0,15 STAHL	WASHER 10X14X0,15 STEEL	X
32	580.36.059.200	DEKO-HEBELFEDER	DECOMP.LEVER SPRING	1
33	0770 100221	O-RING 10,00X2,20 SILICON	O-RING 10,00X2,20 SILICON	1
34	580.36.048.000	ABDECKSCHEIBE	COVER DISK	1
35	580.36.049.500	DEKO-WELLENHEBEL	DECOMPRESSION LEVER	1
36	0021 060003	SCHEIBE DIN 9021 A 6,4	WASHER DIN9021-A 6,4	1
37	0912 060103	ISK.SCHRAUBE DIN 912 M6X10	AH SCREW DIN0912-M 6X10	1

05-584.36.3

* NEUTEIL / NEW PART X NACH BEDARF / AS REQUIRED

STEUERTRIEB » TIMING VALVE

625-660 / 2005

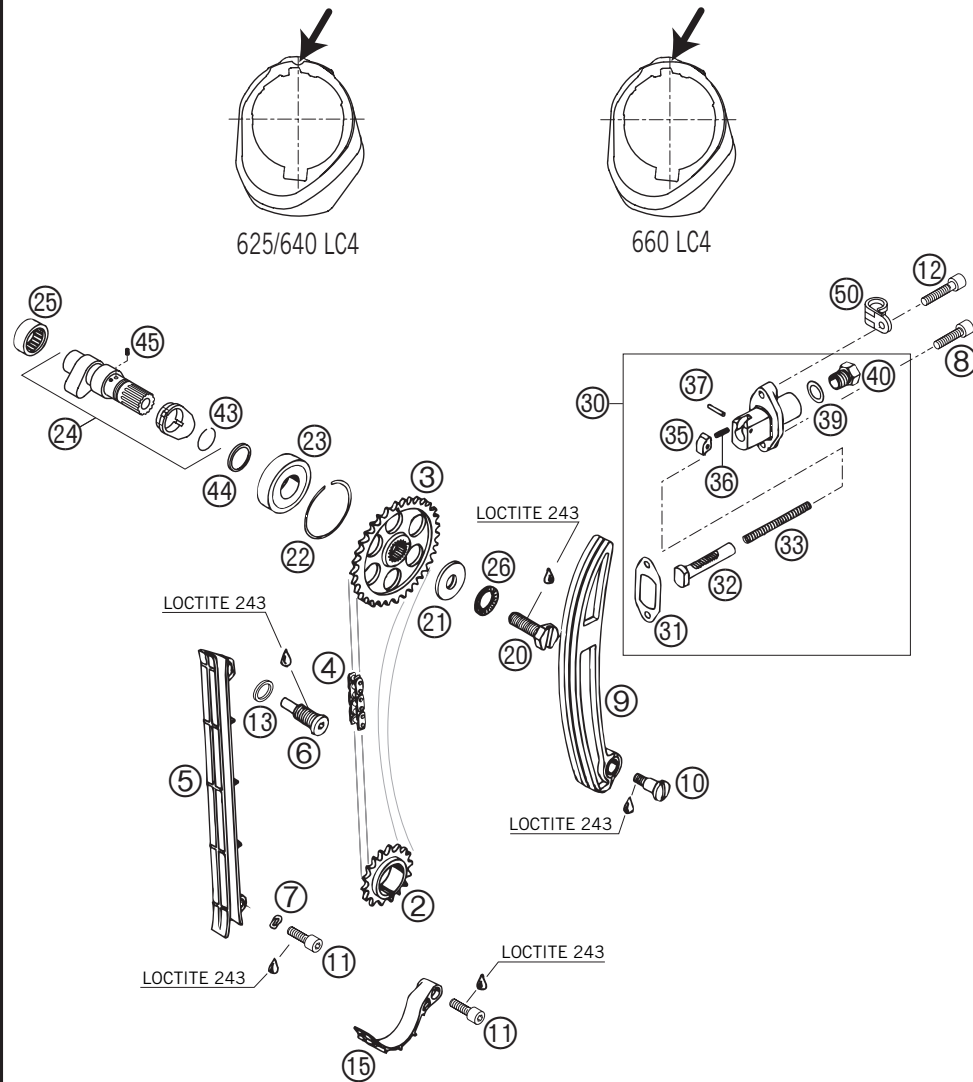

FIG	TEILNR/PARTNR	BEZEICHUNG	DESCRIPTION	QTY
2	580.36.014.000	STEUERRITZEL 17-Z	TIMING GEAR 17-T	1
3	583.36.011.001	NOCKENWELLENRAD 34-Z "01" '94 540/620/625/640 LC4	CAMSHAFT GEAR 34-T "01" '94 540/620/625/640 LC4	1
4	580.36.013.000	STEUERKETTE C107C /100 ROLLEN 540/600/612/620/625/640 LC4	TIMING CHAIN C107C / 100 LINKS 540/600/612/620/625/640 LC4	1
5	580.36.001.000	STEUERKETTENFÜHRUNG 540/600/612/620/625/640 LC4	TIMING CHAIN GUIDE 540/600/612/620/625/640 LC4	1
6	580.36.009.000	KETTENFÜHRUNGSSCHRAUBE	CHAIN GUIDE SCREW	1
7	0137 060003	FEDERSCHEIBE DIN 137 B 6	SPRING WASHER DINO137-B 6	1
8	0912 060253	ISK.SCHRAUBE DIN 912 M6X25	AH SCREW DIN0912-M 6X25	1
9	580.36.002.000	STEUERKETTENSANNER	TIMING CHAIN TENSIONER 540/600/612/620/625/640 LC4	1
9	585.36.002.044	STEUERKETTENSANNER RALLYE 660 LC4	CHAIN TENSIONER RALLYE 660 LC4	1
10	0923 080120	FLACHKOPFSCHRAUBE M 8X12,BLANK	FLAT HEAD SCR. M 8X12	1
11	0912 060208	ISK.SCHRAUBE DIN 912 M6X20 SS	AH SCREW DIN0912-M 6X20 SS	2
12	0912 060303	ISK.SCHRAUBE DIN 912 M6X30	AH SCREW DIN0912-M 6X30	1
13	580.38.022.100	CU-DICHRING 12 X 16 X 2	CU-SEAL RING 12 X 16 X 2	1
15	583.36.018.000	AUSFALLSICHERUNG	SECURING GUIDE	1
20	583.36.112.000	MITNEHMERSCHRAUBE M10X25	DRIVING SCREW M10X25	1
21	580.36.012.000	STAHSCHLEIBE 10 X 28 X 3	STEEL WASHER 10 X 28 X 3	1
22	580.36.096.000	SPRENGRING SB 42	CIRCLIP SB 42	1
23	0625 060040	RILLENKUGELLAGER TMB004	GROOVED BALL BEARING TMB004	1
24*	583.36.110.044	NOCKENWELLE KPL. 249/1 LC4-E 625,640 LC4	CAMSHAFT CPL. 249/1 LC4-E 625,640 LC4	1
24	586.36.010.044	NOCKENWELLE KPL. SM 586V39 03 660 LC4	CAMSHAFT CPL. SM 586V39 03 660 LC4	1
25	580.36.097.000	NADELLAGER TORRINGTON BK2012	NEEDLE BEARING BK 2012	1
26	360.03.014.200	SCHNORR-SICHERUNGSSCHEIBE 10MM	LOCKING WASHER 10MM	1
30	580.36.003.144	AUTOMATIKSANNER KPL.'88	AUTOM.TENSIONER CPL. '88	1
31	580.36.005.100	SPANNERDICHTUNG 1,5 MM	TENSIONER GASKET 1,5 MM	1
32	580.36.004.100	DRUCKBOLZEN	PRESSURE BOLT	1
33	580.36.006.100	DRUCKFEDER 0,9MM	PRESSURE SPRING 0,9MM	1
35	580.36.007.100	KLINKE	RATCHETING PAWL	1
36	580.36.007.050	DRUCKFEDER F. KLINKE	PRES.SPRING F.RATCHETING PAWL	1

05-584.36.1

05-584.36.1

* NEUTEIL / NEW PART X NACH BEDARF / AS REQUIRED

STEUERTRIEB » TIMING VALVE

625-660 / 2005

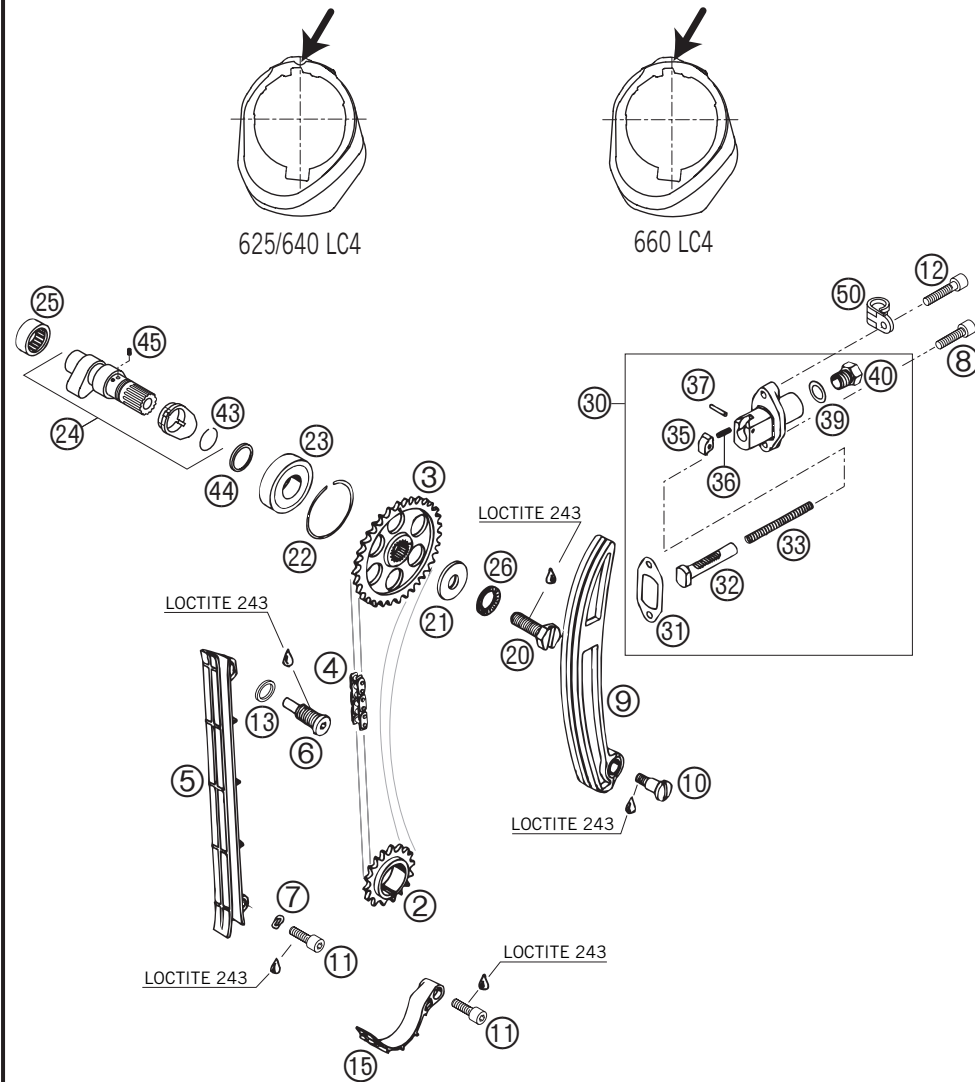
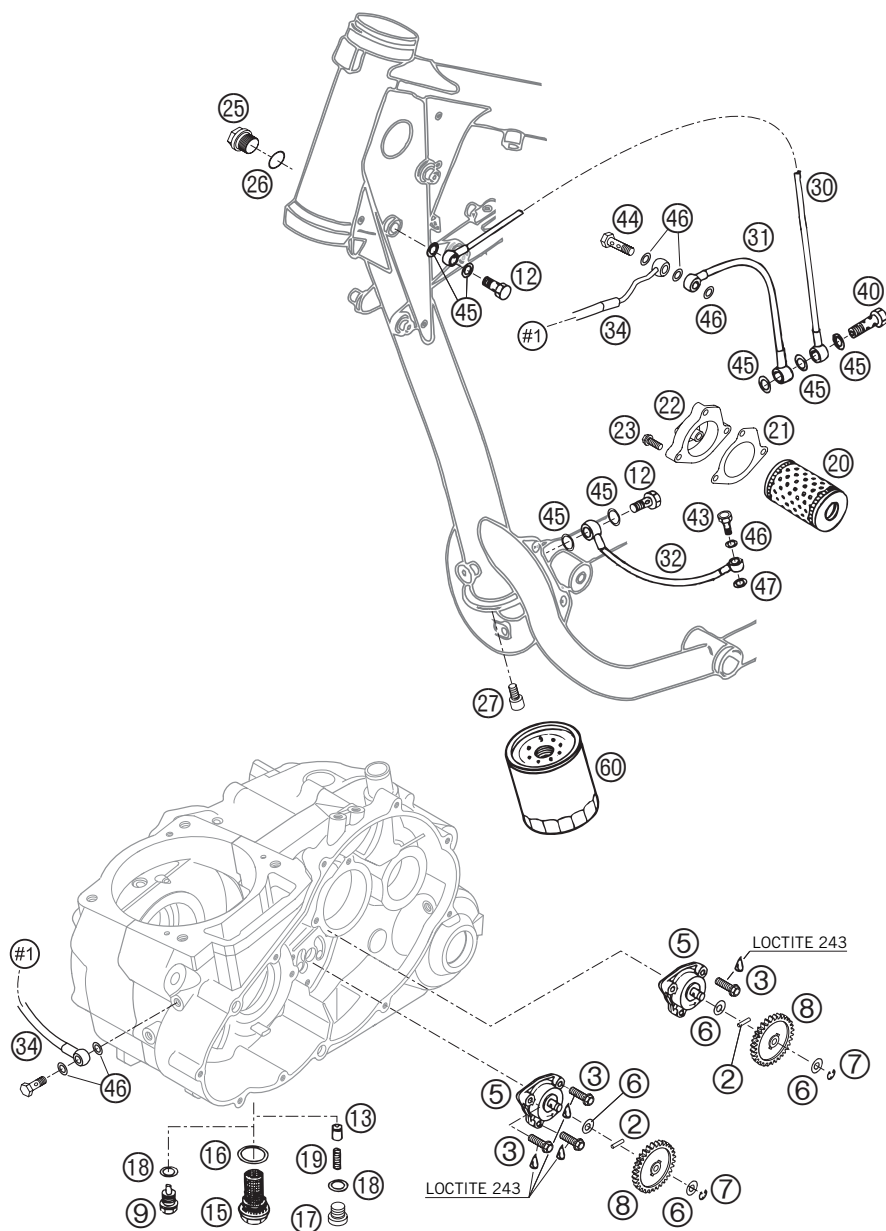

FIG	TEILNR/PARTNR	BEZEICHNUNG	DESCRIPTION	QTY
37	0402 031780	NADELROLLE DIN5402 NRB 3X17,8	NEEDLE ROL. DIN5402 NRB 3X17,8	1
39	580.38.022.000	CU-DICHTRING DIN7603-12X18X1,5	CU-SEAL RING DIN7603-12X18X1,5	1
40	580.36.008.100	VERSCHLUSSSCHRAUBE M12X1,5	PLUG M12X1,5	1
43	0417 200120	SPRENGRING SW20	CIRCLIP WS20	1
44	583.36.015.000	STUFENRING	STEPPED RING	1
45	583.36.016.052	FEDER FÜR AUTODEKO '95	SPRING FOR AUTO-DECOMPR. '95	1
50	542.11.052.000	SCHELLE RSGU 24/15	CLAMP RSGU 24/15	1

05-584.36.1

05-584.36.1

* NEUTEIL / NEW PART X NACH BEDARF / AS REQUIRED



05-584.38.0

FIG	TEILNR/PARTNR	BEZEICHNUNG	DESCRIPTION	QTY
2	0402 251980	NADELROL. DIN5402 NRA 2,5X19,8	NEEDLEROL. DIN5402 NRA 2,5X19,8	2
3	0015 060203	SK.BUNDSCHRAUBE M 6X20 SW=8	HH COLLAR SCREW M 6X20 WS=8	6
5	580.38.007.700	ÖLPUMPE MIKUNI G-73-10	OIL PUMP MIKUNI G-73-10	2
6	580.38.007.755	ANLAUFSCHEIBE 8,1 X 15 X 0,5	STOP DISK 8,1 X 15 X 0,5	4
7	0799 060000	SICH.SCHEIBE DIN6799-RS 6,0	TAB WASHER DIN6799-RS 6,0	2
8	584.38.001.000	ÖLPUMPENRAD 26-Z	OIL PUMP GEAR 26-T	2
9	580.30.021.000	ÖLABLASSCHR.B.MAGNET M 12X1,5	OILDRAIN PLUG W.MAG. M 12X1,5	1
12	543.13.025.000	HOHLSCHRAUBE M10 X 1	HOLLOW SCREW M10 X 1	2
13	580.38.028.000	VENTILKOLBEN D=10MM	VALVE PISTON D=10MM	1
15	580.38.019.100	ÖLVERSCHLUSSSCHRAUBE M22X1,5	OIL DRAIN PLUG M22X1,5	1
16	580.38.017.100	CU-DICHRING DIN7603-22X27X2	CU-SEAL RING DIN7603-22X27X2	1
17	0908 120153	VERSCHL.SCHR. DIN0908-M12X1,5	PLUG DIN0908-M12X1,5	1
18	580.38.022.000	CU-DICHRING DIN7603-12X18X1,5	CU-SEAL RING DIN7603-12X18X1,5	2
19	580.38.023.300	DRUCKFEDER L=25MM D=1MM	PRESSURE SPRING L=25MM D=1MM	1
20*	580.38.005.100	ÖLFILTER LANG	OIL FILTER LONG	1
21	585.30.041.000	ÖLFILTERDECKELDICHTUNG 01	OIL FILTER COVER GASKET 2001	1
22	580.30.008.700	ÖLFILTERDECKEL 2001	OIL FILTER COVER 2001	1
23	0015 060253	SK.BUNDSCHRAUBE M 6X25 SW=8	HH COLLAR SCREW M 6X25 WS=8	3
25	0910 160153	VERSCHL.SCHR. DIN0910-M16X1,5	PLUG DIN0910-M16X1,5	1
26	0603 162220	CU-FÜLLRING 16 X 22 X 2	CU-SEAL RING 16X22X2	1
27	0984 060103	ISK.SCHRAUBE DIN7984-M 6X10	AH SCREW DIN7984-M 6X10	1
30	580.38.234.700	ÖLLEITUNG FILTER-RAHMENROHR R10/R10 - 865MM	OIL LINE FILTER-FRAME TUBE R10/R10 - 865MM	1
31	583.38.034.000	ÖLLEITUNG KUPP.DECKEL-RAHMEN R10/R8 - 206MM	OIL LINE CLUTCH COVER-FRAME R10/R8 - 206MM	1
32*	583.38.034.100	ÖLLEITUNG KUPP.DECKEL-RAHMEN R10/R8 - 240MM	OIL LINE CLUTCH COVER-FRAME R10/R8 - 240MM	1
34*	584.38.034.000	ÖLLEITUNG 8/8 GEBOGEN 05 R8/R8 - 265MM	OIL LINE 8/8 BENT 05 R8/R8 - 265MM	1
40	580.38.033.100	DOPPELHOHLSCHRAUBE M10 X 1	DUAL BANJO BOLT M10 X 1	1
43	580.38.130.000	DÜSENSCHRAUBE M 8 X 1 "150"	JET SCREW M 8 X 1 "150"	1
44*	580.38.033.000	DOPPELHOHLSCHRAUBE M8X1	DUAL BANJO BOLT M8X1	1
45	0603 100141	CU-DICHRING DIN7603-10X14X1	COPPER GASKET DIN7603-10X14X1	7
46*	0603 082121	CU-DICHRING DIN7603- 8X12X1	SEAL RING CU DIN7603- 8X12X1	3
47	580.38.032.300	CU-FÜLLRING 8 X 12 X 1,5	CU-SEAL RING 8 X 12 X 1,5	1
60*	583.38.045.100	SCHRAUBFILTER	SCREW TYPE FILTER	1

05-584.38.0

* NEUTEIL / NEW PART X NACH BEDARF / AS REQUIRED

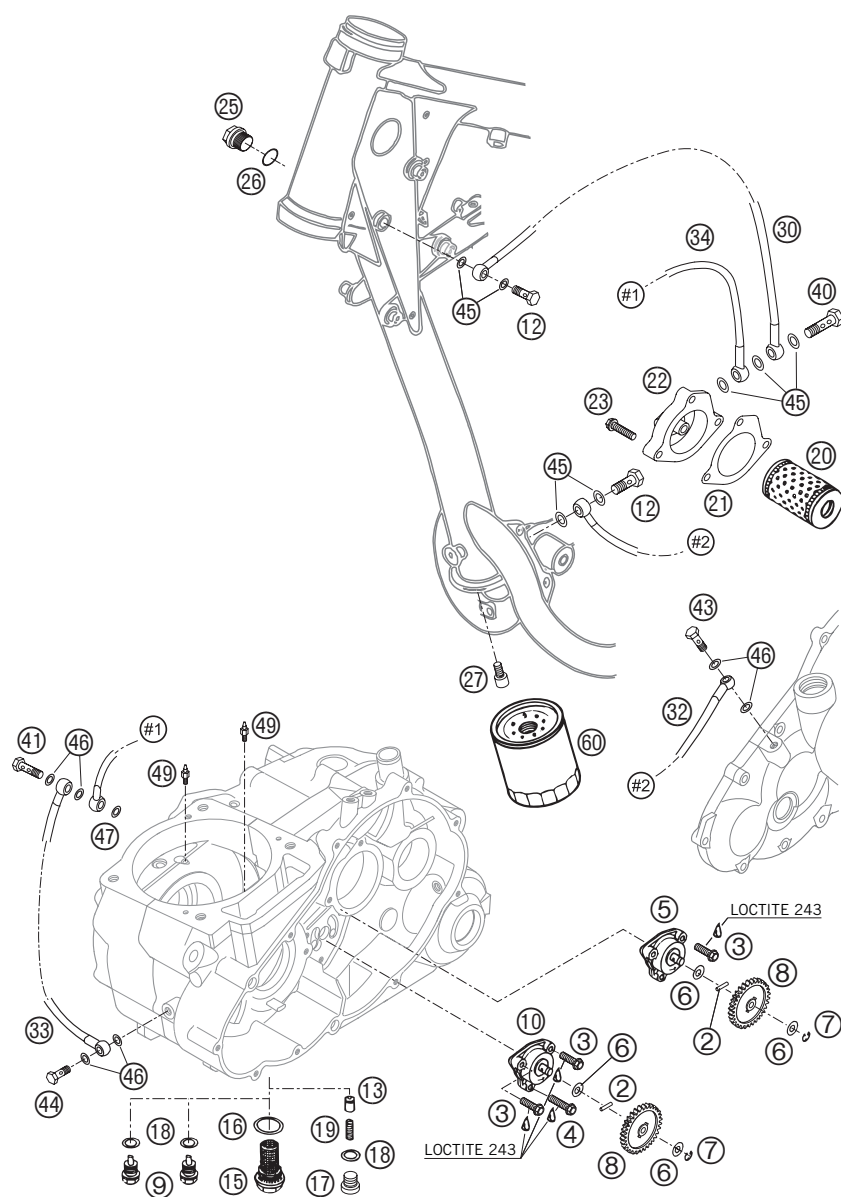

05-586.38.1

FIG	TEILNR/PARTNR	BEZEICHNUNG	DESCRIPTION	QTY
2	0402 251980	NADELROL. DIN5402 NRA 2,5X19,8	NEEDLEROL. DIN5402 NRA 2,5X19,8	2
3	0015 060203	SK.BUNDSCHRAUBE M 6X20 SW=8	HH COLLAR SCREW M 6X20 WS=8	5
4	0015 060253	SK.BUNDSCHRAUBE M 6X25 SW=8	HH COLLAR SCREW M 6X25 WS=8	1
5	580.38.007.700	ÖLPUMPE MIKUNI G-73-10	OIL PUMP MIKUNI G-73-10	1
6	580.38.007.755	ANLAUFSCHEIBE 8,1 X 15 X 0,5	STOP DISK 8,1 X 15 X 0,5	4
7	0799 060000	SICH.SCHEIBE DIN6799-RS 6,0	TAB WASHER DIN6799-RS 6,0	2
8	584.38.001.000	ÖLPUMPENRAD 26-Z	OIL PUMP GEAR 26-T	2
9	580.30.021.000	ÖLABLASSCHR.B.MAGNET M 12X1,5	OILDRAIN PLUG W.MAG. M 12X1,5	2
10	585.38.007.000	ÖLPUMPE MIKUNI G-185 660 99	OIL PUMP MIKUNI G-185 660 99	1
12	543.13.025.000	HOHLSCHRAUBE M10 X 1	HOLLOW SCREW M10 X 1	2
13	580.38.028.000	VENTILKOLBEN D=10MM	VALVE PISTON D=10MM	1
15	580.38.019.100	ÖLVERSCHLUSSCHRAUBE M22X1,5	OIL DRAIN PLUG M22X1,5	1
16	580.38.017.100	CU-DICHRING DIN7603-22X27X2	CU-SEAL RING DIN7603-22X27X2	1
17	0908 120153	VERSCHL.SCHR. DIN0908-M12X1,5	PLUG DIN0908-M12X1,5	1
18	580.38.022.000	CU-DICHRING DIN7603-12X18X1,5	CU-SEAL RING DIN7603-12X18X1,5	3
19	585.38.023.000	ÖLDRUCKFEDER 5 BAR ROT 2001	OIL PRES.SPRING 5 BAR RED 2001	1
20*	580.38.005.100	ÖLFILTER LANG	OIL FILTER LONG	1
21	585.30.041.000	ÖLFILTERDECKELDICHTUNG 01	OIL FILTER COVER GASKET 2001	1
22	580.30.008.700	ÖLFILTERDECKEL 2001	OIL FILTER COVER 2001	1
23	0015 060253	SK.BUNDSCHRAUBE M 6X25 SW=8	HH COLLAR SCREW M 6X25 WS=8	3
25	0910 160153	VERSCHL.SCHR. DIN0910-M16X1,5	PLUG DIN0910-M16X1,5	1
26	0603 162220	CU-FÜLLRING 16 X 22 X 2	CU-SEAL RING 16X22X2	1
27	0984 060103	ISK.SCHRAUBE DIN7984-M 6X10	AH SCREW DIN7984-M 6X10	1
30	580.38.234.700	ÖLLEITUNG FILTER-RAHMENROHR R10/R10 - 865 MM	OIL LINE FILTER-FRAME TUBE R10/R10 - 865 MM	1
32	583.38.034.100	ÖLLEITUNG KUPP.DECKEL-RAHMEN R10/R8 - 240 MM	OIL LINE CLUTCH COVER-FRAME R10/R8 - 240 MM	1
33	585.38.044.000	ÖLL. VERT.-GEH.LI.RE. 260MM 01	OIL LINE CASE L/S R/S 260MM 01	1
34	580.38.334.600	ÖLLEITUNG FILTER/ÖLSPRITZD.RE R10/8 - 175 MM	OIL LINE FILTER/INJECT.VA. R/S R10/8 - 175 MM	1
40	580.38.033.100	DOPPELHOHLSCHRAUBE M10 X 1	DUAL BANJO BOLT M10 X 1	1
41	580.38.033.000	DOPPELHOHLSCHRAUBE M8X1	DUAL BANJO BOLT M8X1	1
43	580.38.130.000	DÜSENSCHRAUBE M 8 X 1 "150"	JET SCREW M 8 X 1 "150"	1
44	580.38.030.000	HOHLSCHRAUBE M 8 X 1 DIN7643	BANJO BOLT M8 X 1 DIN7643	1
45	0603 100141	CU-DICHRING DIN7603-10X14X1	COPPER GASKET DIN7603-10X14X1	7
46*	0603 082121	CU-DICHRING DIN7603- 8X12X1	SEAL RING CU DIN7603- 8X12X1	6
47	0603 821220	DICHRING 8,2X12X2 MM CU 01	COPPER GASKET 8,2X12X2 MM 2001	1
49	600.30.064.070	ÖLSPRITZDÜSE 70 M6X0,75 SW8 03	OIL JET 70 M6X0,75 WS8 03	2
60*	583.38.045.100	SCHRAUBFILTER	SCREW TYPE FILTER	1

05-586.38.1

* NEUTEIL / NEW PART X NACH BEDARF / AS REQUIRED

MOTORENTLÜFTUNG » BREATHER SYSTEM

625-660 / 2005

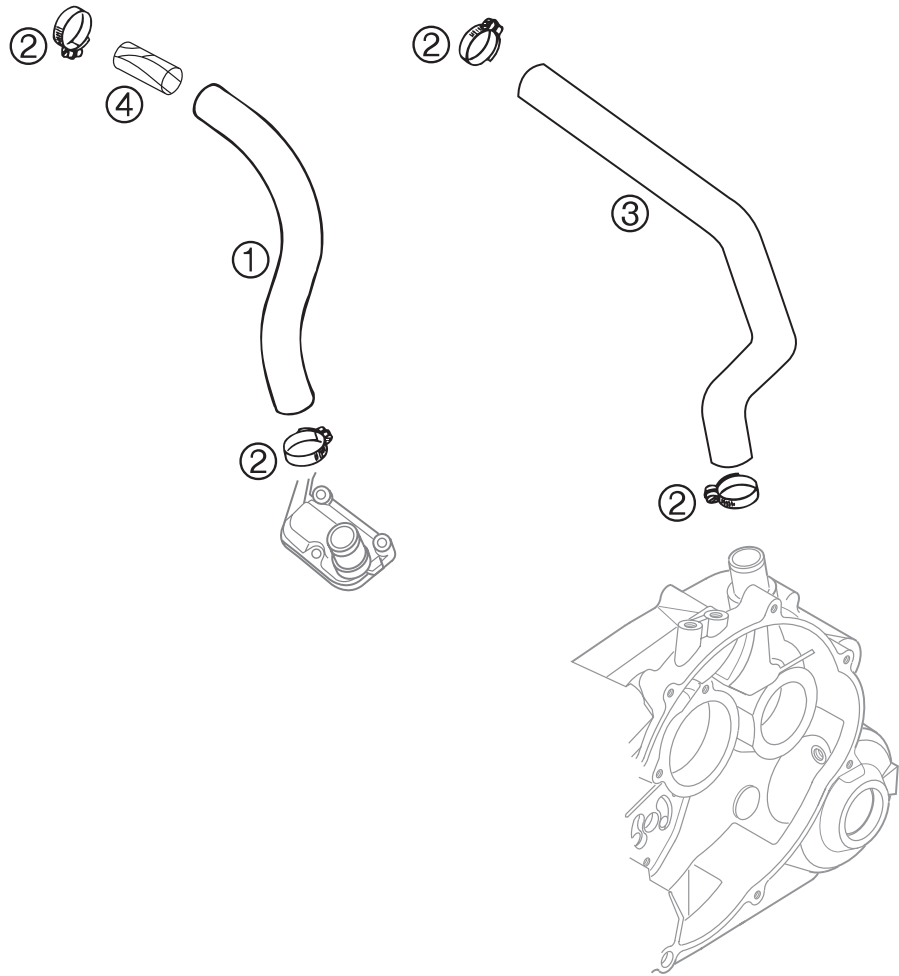

FIG	TEILNR/PARTNR	BEZEICHNUNG	DESCRIPTION	QTY
1	584.30.087.000	MOTORENTLÜFTUNGSSCHL. OBEN 03	ENGINE BREATHER TUBE TOP	1
2	420.13.037.200	SCHLAUCHBINDER GEMI 12/22	HOSE CLAMP GEMI 12/22	4
3	575.30.090.000	ENTLÜFTUNGSSCHLAUCH '93	BREATHER TUBE ENGINE '93	1
4	584.30.089.000	FILTER FÜR MOTORENTLÜFTUNG '98	FILTER BREATHER SYSTEM '98	1

02-584.38.8

02-584.38.8

* NEUTEIL / NEW PART X NACH BEDARF / AS REQUIRED

VERGASER KEIHIN » CARBURETOR KEIHIN

625/660 / 2005

ACHTUNG !!!
Vor dem Einbau des Vergasers, Bedüsung kontrollieren.
CAUTION !!!
Before mounting the carburetor, check the jetting.

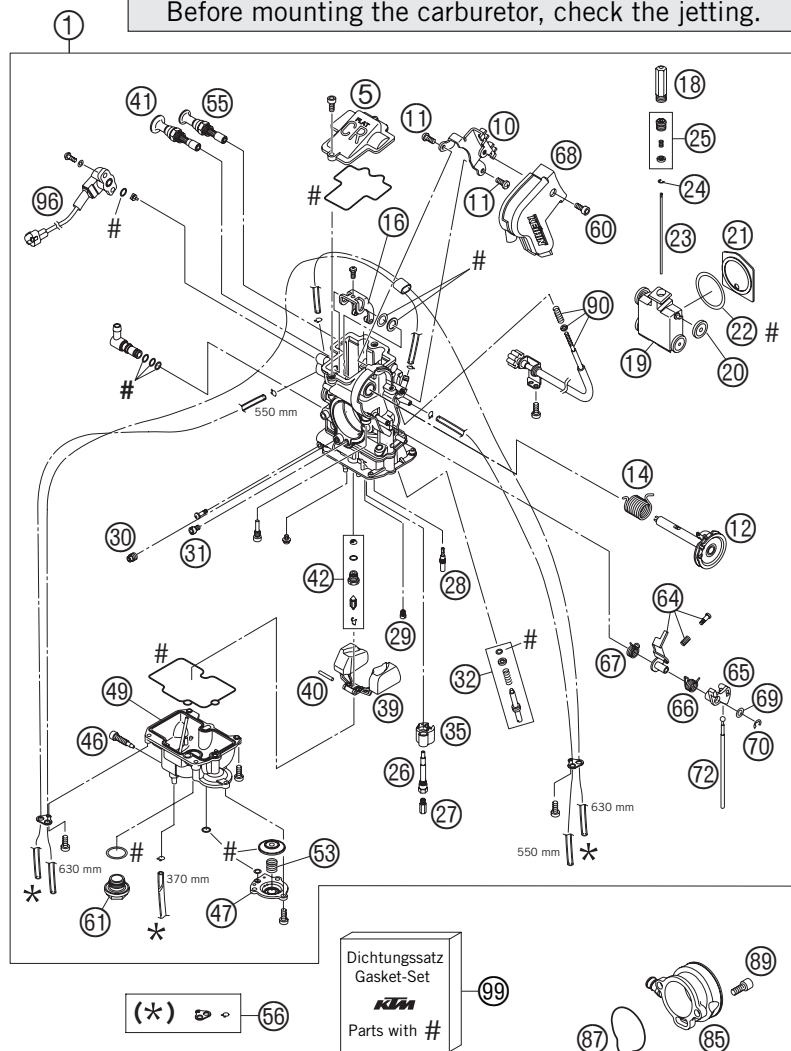

05-583.31.0

FIG	TEILNR/PARTNR	BEZEICHNUNG	DESCRIPTION	QTY
1	583.31.001.100	VERGASER KEIHIN FCR-41 MX 03	CARBURETOR KEIHIN FCR-41 MX 03	1
5	573.31.027.000	VERGASERDECKEL 2002	CARBURETOR COVER 2002	1
10	573.31.080.000	HALTEBLECH FÜR GASSEILE	BRACKET PLATE FOR THR. CABLE	1
11	573.31.055.000	SCHRAUBE M 5 X 8	SCREW M 5 X 8	2
12	573.31.046.000	SEILZUGROLLE KPL.	THROTTLE SHAFT CPL.	1
14	573.31.046.050	FEDER SEILZUGROLLE	COIL SPRING THROTTLE SHAFT	1
16	573.31.035.051	GASSCHIEBERARM KPL.	LINK ARM THROTTLE VALVE CPL.	1
18	583.31.029.014	SCHIEBERANSCHLAG SXC/SM 03	SLIDE STOP SXC/SM 03	1
19	573.31.035.000	GASSCHIEBER KPL.	THROTTLE VALVE CPL.	1
20	590.31.035.050	LAGERROLLE GASSCHIEBER	BUSHING THROTTLE VALVE	4
21*	573.31.035.153	DICHTPL. GASSCH. FCR-MX M. 04	GASKET PLATE THROTTLE VALVE 04	1
22	590.31.035.052	DICHTSCHEIBE GASSCHIEBER	GASKET WASHER THROTTLE VALVE	1
23	590.31.023.200	DÜSENNADEL KEIHIN OBDVT	JET NEEDLE KEIHIN OBDVT	1
23	573.31.034.100	DÜSENNADEL KEIHIN OBEKP	JET NEEDLE KEIHIN OBEKP	X
23	573.31.034.200	DÜSENNADEL KEIHIN OBEKQ	JET NEEDLE KEIHIN OBEKQ	X
23	573.31.034.300	DÜSENNADEL KEIHIN OBEKR	JET NEEDLE KEIHIN OBEKR	X
23	573.31.034.400	DÜSENNADEL KEIHIN OBEKS	JET NEEDLE KEIHIN OBEKS	X
23	573.31.034.500	DÜSENNADEL KEIHIN OBEKT	JET NEEDLE KEIHIN OBEKT	X
24	590.31.029.000	NADELCLIP	BAR CLIP	1
25	573.31.032.000	NADELSCHRAUBE KPL.	NEEDLE SET SCREW CPL.	1
26	590.31.121.000	NADEL DÜSE FCR-MX	NEEDLE JET FCR-MX	1
27	545.31.623.160	HAUPTDÜSE GR.160 KEIHIN	MAIN JET 160 KEIHIN	X
27	545.31.623.162	HAUPTDÜSE GR.162 KEIHIN	MAIN JET 162 KEIHIN	X
27	545.31.623.165	HAUPTDÜSE GR.165 KEIHIN	MAIN JET 165 KEIHIN	1
27	545.31.623.168	HAUPTDÜSE GR.168 KEIHIN	MAIN JET 168 KEIHIN	X
27	545.31.623.170	HAUPTDÜSE GR.170 KEIHIN	MAIN JET 170 KEIHIN	X
27	545.31.623.172	HAUPTDÜSE GR.172 KEIHIN	MAIN JET 172 KEIHIN	X
27	545.31.623.175	HAUPTDÜSE GR.175 KEIHIN	MAIN JET 175 KEIHIN	X
27	545.31.623.178	HAUPTDÜSE GR.178 KEIHIN	MAIN JET 178 KEIHIN	X
27	545.31.623.180	HAUPTDÜSE GR.180 KEIHIN	MAIN JET 180 KEIHIN	X
27	545.31.623.182	HAUPTDÜSE GR.182 KEIHIN	MAIN JET 182 KEIHIN	X
27	545.31.623.185	HAUPTDÜSE GR.185 KEIHIN	MAIN JET 185 KEIHIN	X
27	545.31.623.188	HAUPTDÜSE GR.188 KEIHIN	MAIN JET 188 KEIHIN	X
27	545.31.623.190	HAUPTDÜSE GR.190 KEIHIN	MAIN JET 190 KEIHIN	X
28	545.31.607.040	LEERLAUFDÜSE GR.40 KEIHIN	IDLE JET 40 KEIHIN	X

04-583.31.0

* NEUTEIL / NEW PART X NACH BEDARF / AS REQUIRED

VERGASER KEIHIN » CARBURETOR KEIHIN

625/660 / 2005

ACHTUNG !!!
Vor dem Einbau des Vergasers, Bedüsung kontrollieren.
CAUTION !!!
Before mounting the carburetor, check the jetting.

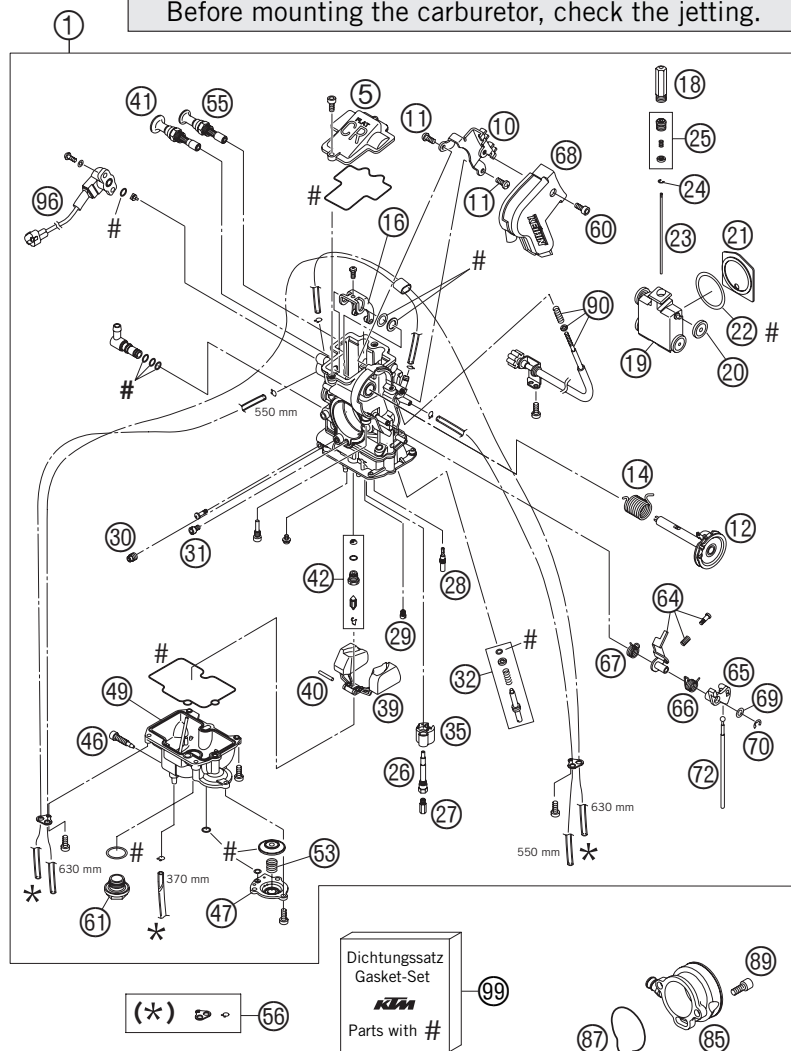

05-583.31.0

FIG	TEILNR/PARTNR	BEZEICHNUNG	DESCRIPTION	QTY
28	545.31.607.042	LEERLAUFDÜSE GR.42 KEIHIN	IDLE JET 42 KEIHIN	1
28	545.31.607.045	LEERLAUFDÜSE GR.45 KEIHIN	IDLE JET 45 KEIHIN	X
29	590.31.051.085	STARTDÜSE 85	STARTER JET 85	1
30	573.31.007.100	LEERLAUFLUFTDÜSE GR.100 KEIHIN	IDLE AIR JET 100 KEIHIN	1
31	573.31.037.200	HAUPTLUFTDÜSE GR.200 KEIHIN	MAIN AIR JET 200 KEIHIN	1
32	590.31.017.100	GEMISCHREGULIERSCHR.KPL.FCR-MX	ADJUST SCREW CPL. FCR-MX	1
35	573.31.085.000	DÄMPFUNGSKÖRPER	BUFFER PLATE	1
39	573.31.009.000	SCHWIMMER KPL.	FLOAT CPL.	1
40	573.31.008.000	STIFT SCHWIMMER	ARM PIN FLOAT	1
41	573.31.075.000	WARMSTARTBETÄTIGUNG KPL.	HOT-STARTER VALVE CPL.	1
42	573.31.020.000	SCHWIMMERNADELVENTIL KPL.	NEEDLE VALVE CPL.	1
46	573.31.155.000	ABLASSSCHRAUBE SCHWIMMERGEH.	DRAIN SCREW FLOAT CHAMBER	1
47	573.31.060.000	GEHÄUSE BESCHLEUNIGERPUMPE	COVER ACCELERATOR PUMP	1
49	573.31.011.000	SCHWIMMERGEHÄUSE	FLOAT CHAMBER	1
53	590.31.059.000	DRUCKFEDER	COIL SPRING	1
55	573.31.048.000	KALTSTARTBETÄTIGUNG KPL.	STARTER VALVE CPL.	1
56	573.31.098.000	ENTL.SCHL. FCR-MX KEIHIN KPL.	BREATH.HOSE FCR-MX KEIHIN CPL.	1
60	573.31.038.100	SCHRAUBE F. ABDECKUNG KEIHIN	SCREW F. COVER KEIHIN	1
61	573.31.014.000	VERSCHLUSSSCHRAUBE	HOLDING BOLT	1
64	573.31.062.000	VERBINDUNGSHEBEL KPL.	INTERMEDIATE LEVER CPL.	1
65	573.31.056.000	ANLENKHEBEL	LINK LEVER	1
66	573.31.059.000	FEDER ANLENKHEBEL	SPRING LINK LEVER	1
67	573.31.159.000	FEDER VERBINDUNGSHEBEL	SPRING INTERMEDIATE LEVER	1
68	573.31.038.000	VERGASER ABDECKUNG	CARBURETOR COVER	1
69	573.31.087.000	SCHEIBE ANLENKHEBEL	WASHER LINK LEVER	1
70	573.31.084.000	SICHERUNGSSCHEIBE E-FORM	E-CLIP	1
72	573.31.061.000	GESTÄNGE BESCHLEUNIGERPUMPE	ROD ACCELERATOR PUMP	1
85	590.31.040.200	ANSAUGTRICHTER FCR/FCR-MX 02 SEITLICH GESCHLOSSEN	INTAKE FUNNEL FCR/FCR-MX 02 SIDEWARDS CLOSED	1
87	590.31.040.010	O-RING FÜR ANSAUGTRICHTER	O-RING FOR INTAKE FUNNEL	1
89	0912 050123	ISK.SCHRAUBE DIN 912 M5X12	AH SCREW DIN0912-M 5X12	2
90	573.31.025.000	STELLSCHRAUBE KPL. FCR-MX	STOP SCREW CPL. FCR-MX	1
96	583.31.077.000	SENSOR GASSCHIEBERPOS. '03	THROTTLE POSITION SENSOR '03	1
99	573.31.099.000	DICHTUNGSSATZ FCR-MX KEIHIN	GASKET SET FCR-MX KEIHIN	1

04-583.31.0

* NEUTEIL / NEW PART X NACH BEDARF / AS REQUIRED

VERGASER MIKUNI » CARBURETOR MIKUNI

640 / 2005

ACHTUNG !!!
Vor dem Einbau des Vergasers, Bedüsung kontrollieren.
CAUTION !!!
Before mounting the carburetor, check the jetting.

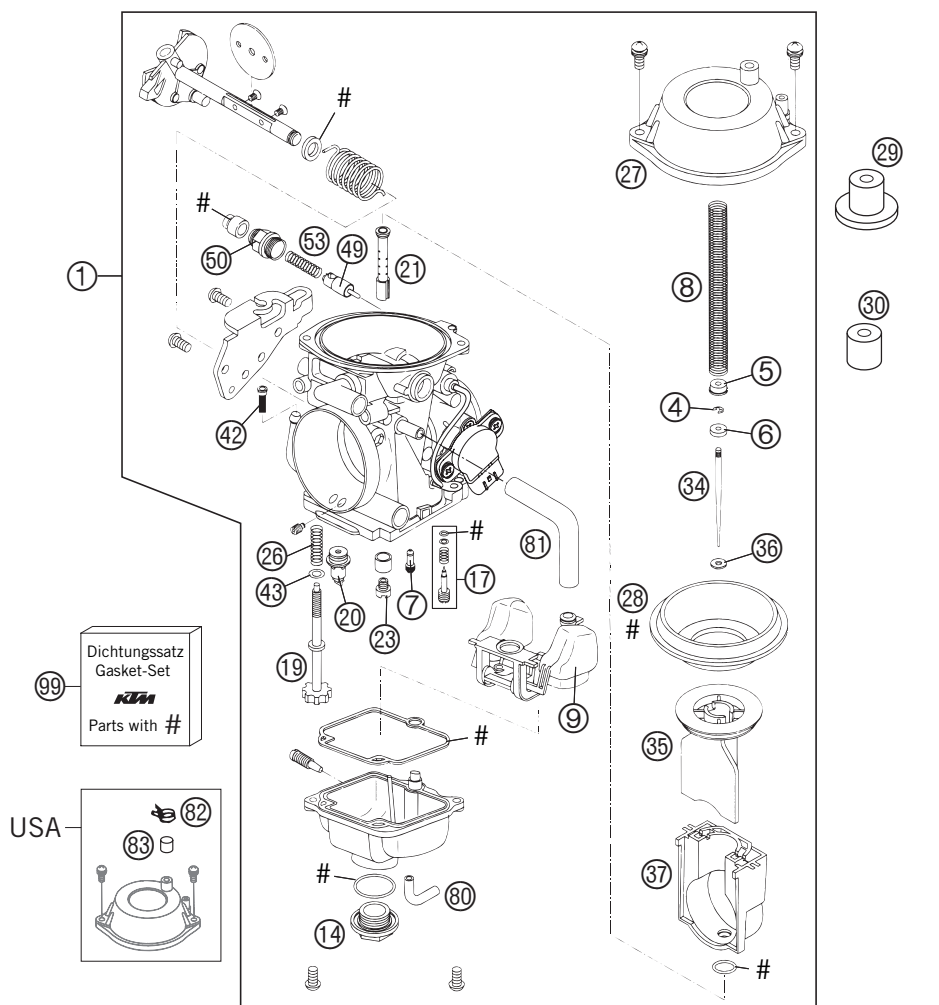

05-584.31.1

FIG	TEILNR/PARTNR	BEZEICHNUNG	DESCRIPTION	QTY
1	584.31.001.600	VERGASER MIKUNI BST40-266 03	CARBURETOR MIKUNI BST40-266 03	1
4	584.31.045.000	SICHERUNGSRING	CIRCLIP	1
5	584.31.031.000	FEDERTELLER	SPRING RING	1
6	584.31.032.000	KUNSTSTOFFSCHEIBE	PLASTIC RING	1
7	584.31.007.045	LEERLAUFDÜSE 45	IDLING JET 45	1
7	584.31.007.047	LEERLAUFDÜSE 47,5	IDLING GET 47,5	X
8	584.31.030.000	GASSCHIEBERFEDER	THROTTLE VALVE SPRING	1
9	584.31.009.000	SCHWIMMER 6,1 GRAMM MIKUNI	FLOAT 6,1 GRAMM MIKUNI	1
14	584.31.014.000	VERSCHLUSSSCHRAUBE SCHWIMMERG.	SCREW PLUG FLOAT CHAMBER	1
17	584.31.017.000	GEMISCHREGULIERSCHRAUBE KPL.	ADJUST SCREW CPL.	1
19	584.31.019.000	EINSTELLSCHRAUBE LEERLAUFDREH.	ADJUSTER IDLING SPEED	1
20	584.31.020.000	NADELVENTIL MESSING 2,8MM	NEEDLE VALVE 2,8MM	1
21	584.31.021.689	NAELEDÜSE 689 X-6	NEEDLE JET 689 X-6	1
23	584.31.023.140	HAUPTDÜSE 140	MAIN JET 140	X
23	584.31.023.142	HAUPTDÜSE 142,5	MAIN JET 142,5	X
23	584.31.023.145	HAUPTDÜSE 145	MAIN JET 145	X
23	584.31.023.147	HAUPTDÜSE 147,5	MAIN JET 147,5	X
23	584.31.023.150	HAUPTDÜSE 150	MAIN JET 150	X
23	584.31.023.152	HAUPTDÜSE 152,5 ENDURO, ADVENTURE	MAIN JET 152,5 ENDURO, ADVENTURE	1
23	584.31.023.155	HAUPTDÜSE 155	MAIN JET 155	X
23	584.31.023.157	HAUPTDÜSE 157,5	MAIN JET 157,5	X
23	584.31.023.160	HAUPTDÜSE 160	MAIN JET 160	X
23	584.31.023.162	HAUPTDÜSE 162,5	MAIN JET 162,5	X
23	584.31.023.165	HAUPTDÜSE 165 SM, DUKE	MAIN JET 165 SM, DUKE	1
23	584.31.023.167	HAUPTDÜSE 167,5	MAIN JET 167,5	X
23	584.31.023.170	HAUPTDÜSE 170	MAIN JET 170	X
23	584.31.023.172	HAUPTDÜSE 172,5	MAIN JET 172,5	X
23	584.31.023.175	HAUPTDÜSE 175	MAIN JET 175	X
23	584.31.023.177	HAUPTDÜSE 177,5	MAIN JET 177,5	X
23	584.31.023.180	HAUPTDÜSE 180	MAIN JET 180	X
26	584.31.026.000	FEDER FÜR EINSTELLSCHRAUBE	SPRING FOR ADJUSTER	1
27	584.31.027.000	MEMBRANDECKEL MIKUNI	DIAPHRAGM COVER MIKUNI	1
28	584.31.028.000	MEMBRAN FÜR GASSCHIEBER MIKUNI	DIAPHRAGM FOR THROTTLE VALVE	1

05-584.31.1

* NEUTEIL / NEW PART X NACH BEDARF / AS REQUIRED

VERGASER MIKUNI » CARBURETOR MIKUNI

640 / 2005

ACHTUNG !!!
Vor dem Einbau des Vergasers, Bedüsung kontrollieren.
CAUTION !!!
Before mounting the carburetor, check the jetting.

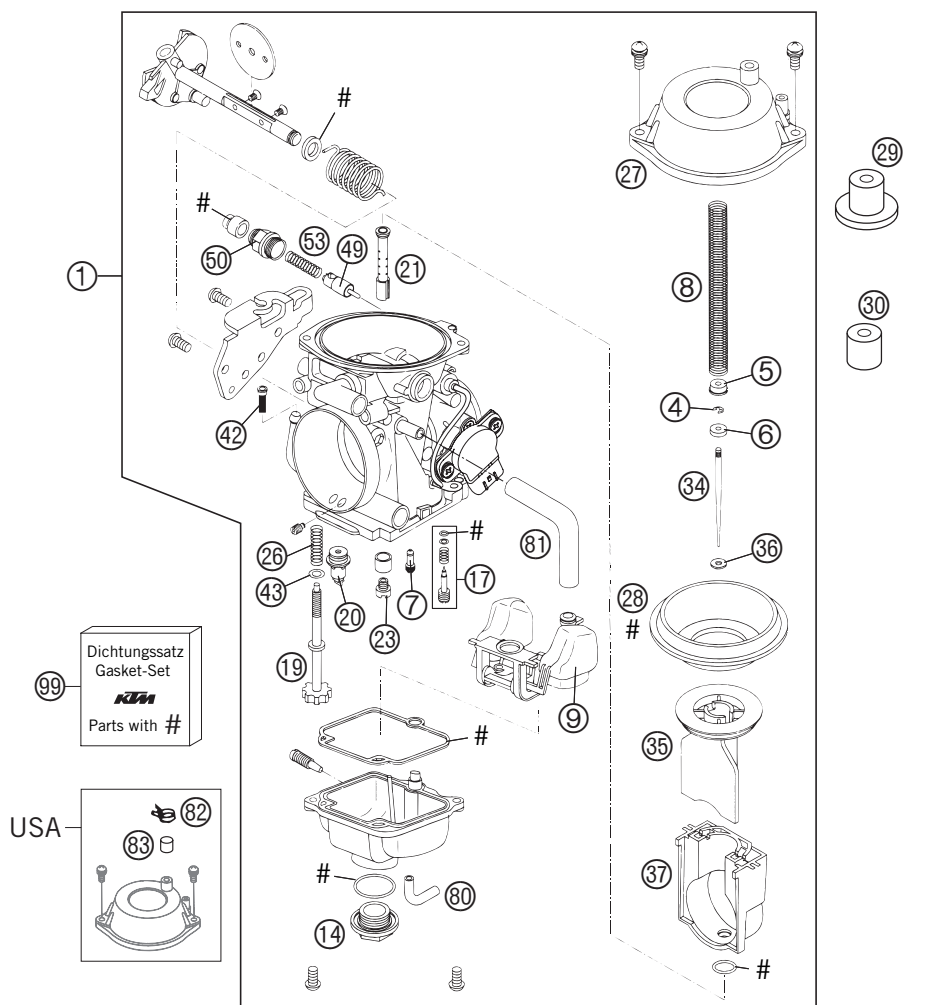

FIG	TEILNR/PARTNR	BEZEICHNUNG	DESCRIPTION	QTY
29	583.31.029.017	SCHIEBERANSCHLAG L=17MM	SLIDE STOP L=17MM MIKUNI	X
30*	586.31.029.020	SCHIEBERANSCHLAG 20MM SM, DUKE	SLIDE STOP 20MM SM, DUKE	05 1
34	584.31.034.6G5	DÜSENNADEL 6G5	JET NEEDLE 6G5	1
35	584.31.035.000	GASSCHIEBER "1"	THROTTLE VALVE "1"	1
36	584.31.132.000	SCHEIBE DÜSENNADEL	SHIM JET NEEDLE	1
37	584.31.037.000	GASSCHIEBERFÜHRUNG KUNSTSTOFF	THROTTLE VALVE GUIDE PLASTIC	1
42	584.31.042.000	KRAFTSTOFFSIEB MIKUNI	FUEL SCREEN MIKUNI	1
43	584.31.043.000	DICHRING FÜR EINSTELLSCHRAUBE	PACKING RING FOR ADJUSTER	1
49	584.31.049.000	STARTKOLBEN MIKUNI	STARTING PISTON MIKUNI	1
50	584.31.050.000	VERSCHRAUBUNG M12 STARTSYSTEM	SCREW M12 STARTSYSTEMN	1
53	584.31.053.000	FEDER 22,5MM FÜR STARTKOLBEN	SPRING 22,5MM FOR START.PISTON	1
80	520.31.137.001	PVC-SCHLAUCH 3X5MM	PVC-HOSE 3X5MM	0,5
81	544.35.024.001	ND-SCHLAUCH ID 7,5 PER METER	HOSE ID 7,5 PER METER	0,5
82	580.31.005.000	YDNAC KLAMMER 10128 12MM	CLAMP YDNAC 10128 12MM	1
83	579.31.001.010	VERSCHL.KAPPE F. EPC-ANSCHLUSS	PLUG CAP FOR EPC CONNECTION	1
99	584.31.099.000	DICHTUNGSSATZ MIKUNI BST40-225	GASKET SET MIKUNI BST40-225	1

05-584.31.1

05-584.31.1

* NEUTEIL / NEW PART X NACH BEDARF / AS REQUIRED

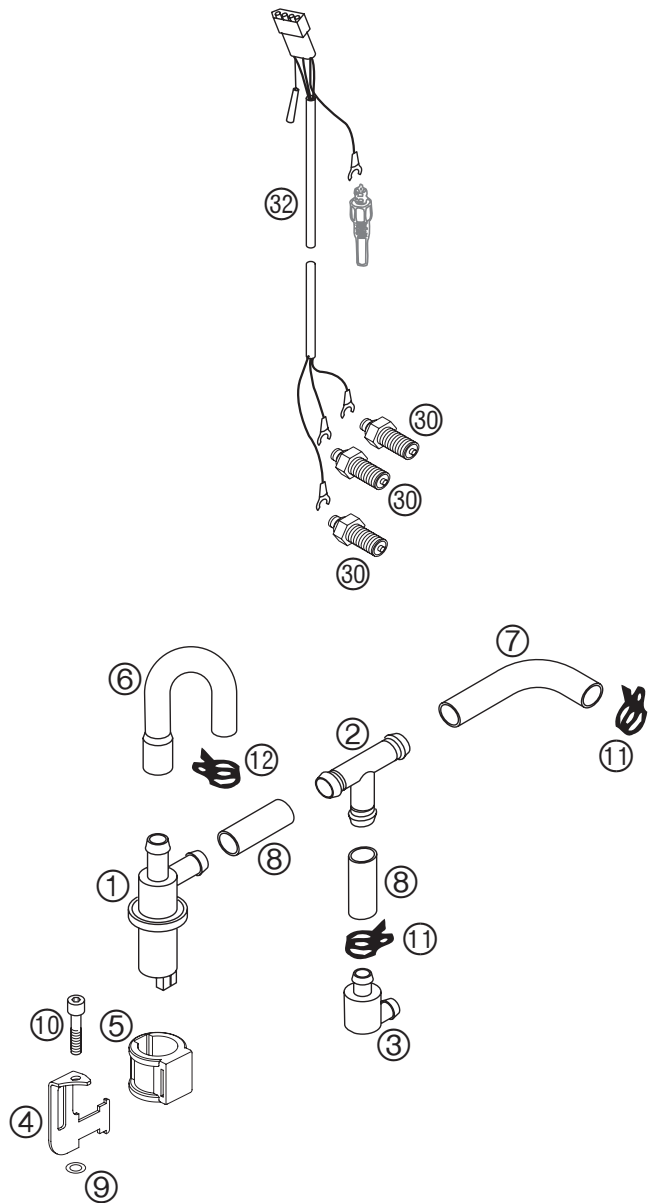

FIG	TEILNR/PARTNR	BEZEICHNUNG	DESCRIPTION	QTY
1	584.31.067.000	MAGNETVENTIL PIRBURG F.EPC '98	MAGNETIC VALVE PIRBURG EPC '98	1
2	584.31.072.000	T-STÜCK 12MM LC4 '98	T-CONNECTION 12MM LC4 '98	1
3*	584.31.070.100	LUFTFILTER LC4 FÜR EPC 2005	AIR FILTER LC4 FOR EPC 2005	1
4	584.31.069.100	HALTEBLECH F. MAGNETVENTIL '03	BRACKET FOR MAGNETIC VALVE '03	1
5	600.31.068.000	HALTEGUMMI F. MAGNETVENTIL '03	RUBBER SUPPORT F. MAG. VALVE '03	1
6	584.31.071.000	UNTERDRUCKSCH. FÜR MAGNETV.'98	VACUUM HOSE FOR MAGNETIC V.'98	1
7	584.31.097.000	WINKELSCHL.T-STÜCK-VERGASER'98	ANGULAR HOSE T-CON.-CARBURETOR	1
8	584.31.097.100	SCHLAUCH 12MM T-STK.-FILTER'98	TUBE 12MM T-CON.-FILTER '98	2
9*	580.36.065.100	CU-DICHTRING 6 X 10 X 2	CU-SEAL RING 6 X 10 X 2	1
10	0912 060303	ISK.SCHRAUBE DIN 912 M6X30	AH SCREW DIN0912-M 6X30	1
11	584.31.082.000	YDNAC-KLAMMER 10164 (15MM) '98	YDNAC-CLAMP 15MM '98	2
12	584.31.082.100	YDNAC-KLAMMER 10173 (16MM) '98	YDNAC-CLAMP 10173 (16MM) '98	1
30	580.11.081.100	KONTAKTSCHRAUBE M10 STAHL '98	CONTACT SCREW M10 STEEL '98	3(1)
32	584.11.085.000	KABELSTRANG EPC FÜR MOTOR LC4	WIRING HARN. EPC F. ENGINE LC4	1

05-584.31.9

05-584.31.9

* NEUTEIL / NEW PART X NACH BEDARF / AS REQUIRED

ZÜNDANLAGE KOKUSAN » IGNITION SYSTEM KOKUSAN

625/640 / 2005

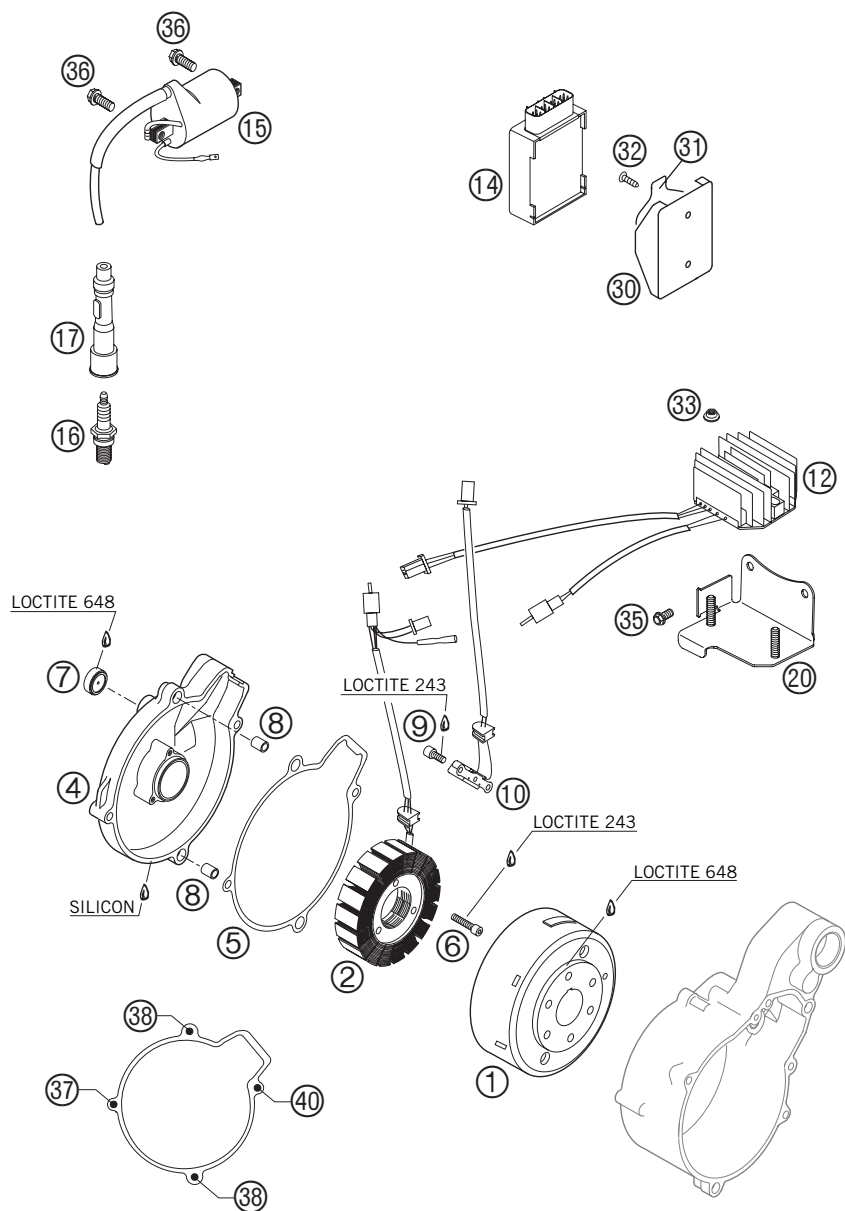

FIG	TEILNR/PARTNR	BEZEICHNUNG	DESCRIPTION	QTY
1	584.39.005.100	ROTOR KOKUSAN LOSE GP9128 '97	FLYWHEEL KOKUSAN GP9128 '97	1
2	584.39.004.000	STATOR KOKUSAN LOSE '96	STATOR KOKUSAN LOOSE '96	1
4	584.30.002.144/23	ZÜNDUNGSDECKEL KPL. GRAU 03 MIT ÖLSCHAUGLAS	IGNITION COVER CPL. GREY 03 WITH OIL INSPECTION GLASS	1
5	584.30.040.000	ZÜNDUNGSDECKELDICHTUNG '96	IGNITION COVER GASKET '96	1
6	0912 050253	ISK.SCHRAUBE DIN 912 M5X25	AH SCREW DIN912-M 5X25	3
7	584.30.095.000	ÖLSCHAUGLAS GW 20-7	INSPECTION GLASS GW 20-7	1
8	490.30.090.000	PASSHÜLSE 9,8 X 7 X 10	DOWEL 9,8 X 7 X 10	2
9	0912 050083	ISK.SCHRAUBE DIN 912 M 5X8	AH SCREW DIN 912 M 5X8	2
10	584.39.034.000	IMPULSGEBER	PULSER COIL	1
12	584.11.034.100	REGLER-GLEICHRICHTER 12V '97	VOLT.REGULATOR-RECTIFIER 12V	1
14*	583.39.031.300	CDI 625 SXC 05	CDI 625 SXC 05	1
14*	586.39.031.200	CDI 625 SMC 05	CDI 625 SMC 05	1
14*	586.39.031.000	CDI 640 DUKE/SM 05	CDI 640 DUKE/SM 05	1
14*	584.39.031.900	CDI 640 ADV., ENDURO 05	CDI 640 ADV., ENDURO 05	1
15	584.39.006.000	ZÜNDSPULE IG3826 KOKUSAN '96	IGNITIONCOIL IG3826 KOKUSAN'96	1
16	590.39.093.100	ZÜNDKERZE NGK DCPR8E 03	SPARK PLUG NGK DCPR8E 03	1
17	584.39.090.000	ZÜNDKERZENSTECKER SD05EG 03	SPARK PLUG CONNECT. SD05EG 03	1
20	584.11.055.200	BATTERIEHALTEBÜGEL 03	BATTERY BRACKET 03	1
30	584.39.030.200	GUMMIHALTER FÜR DIGITALBOX 03	RUBBER BRACKET FOR DIGI-BOX 03	1
31	584.39.030.250	HALTEBLECH FÜR GUMMIHALTER 03	SUPPORT FOR RUBBER BRACKET 03	1
32	0017 050181	SCHRAUBE FÜR KUNSTSTOFF D=5X18	SCREW FOR PLASTIC D=5X18	2
33	565.09.064.100	STOVER-FLANSCHMUTTER M6 10.9	SELF LOCKING NUT M6 10.9	2
35	0015 060103	SK.BUNDSCHRAUBE M 6X10 SW=8	HH COLLAR SCREW M 6X10 WS=8	2
36	0015 060163	SK.BUNDSCHRAUBE M 6X16 SW=8	HH COLLAR SCREW M 6X16 WS=8	2
37	0015 060253	SK.BUNDSCHRAUBE M 6X25 SW=8	HH COLLAR SCREW M 6X25 WS=8	1
38	0015 060303	SK.BUNDSCHRAUBE M 6X30 SW=8	HH COLLAR SCREW M 6X30 WS=8	2
40	0015 060803	SK.BUNDSCHRAUBE M 6X80 SW=8	HH COLLAR SCREW M 6X80 WS=8	1

05-584.39.0

05-584.39.0

* NEUTEIL / NEW PART X NACH BEDARF / AS REQUIRED

ZÜNDANLAGE KOKUSAN » IGNITION SYSTEM KOKUSAN

660 / 2005

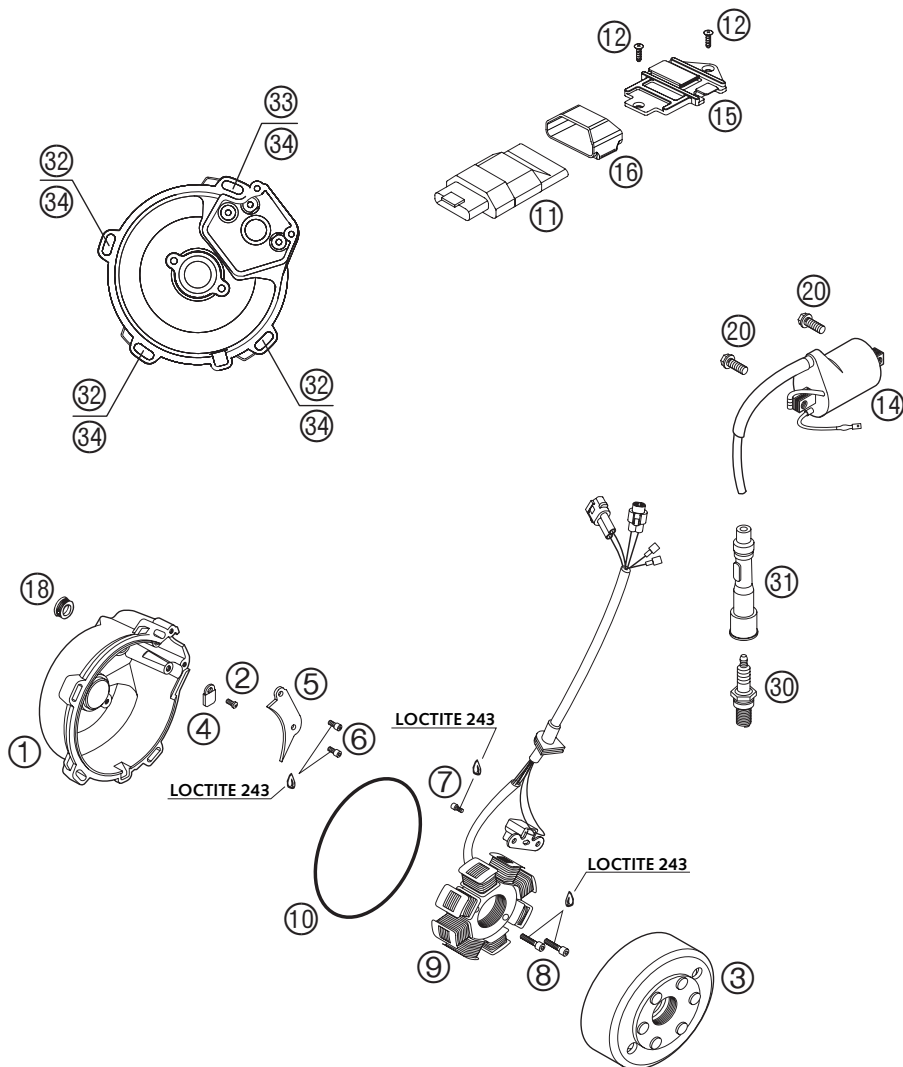

FIG	TEILNR/PARTNR	BEZEICHNUNG	DESCRIPTION	QTY
1	583.30.002.000/23	ZÜNDUNGSDECKEL 4K3 GRAU 03	IGNITION COVER 4K3 GREY 03	1
2	0500 050083	GEW.FURCHSCHR. DIN7500-M5X8	SPECIAL SCREW DIN7500-M 5X 8	1
3	586.39.005.100	ROTOR KOKUSAN 660 SM 04	FLYWHEEL KOKUSAN 660 SM 04	1
4	500.31.003.000	HALTEPLÄTTCHEN	RETAINING PLATE	1
5	583.30.002.050	VERSCHLUBBLECH 4K3	CLOSING COVER 4K3	1
6	0912 050123	ISK.SCHRAUBE DIN 912 M5X12	AH SCREW DIN0912-M 5X12	2
7	0912 050153	ISK.SCHRAUBE DIN0912-M 5X15	AH SCREW DIN0912-M 5X15	2
8	0912 060203	ISK.SCHRAUBE DIN 912 M6X20	AH SCREW DIN0912-M 6X20	2
9	583.39.004.100	STATOR KOKUSAN 4K3 SC 2002	STATOR KOKUSAN 4K3 SC 2002	1
10	0770 020490	O-RING 126,72X1,78 B70	O-RING 126,72X1,78 B70	1
11*	586.39.031.100	CDI 660 SMC 05	CDI 660 SMC 05	1
12*	0017 050181	SCHRAUBE FÜR KUNSTSTOFF D=5X18	SCREW FOR PLASTIC D=5X18	2
14	584.39.006.000	ZÜNDSPULE IG3826 KOKUSAN '96	IGNITIONCOIL IG3826 KOKUSAN'96	1
15*	586.39.030.000	HALTER FÜR CDI 05	HOLDER FOR CDI 05	1
16*	800.39.030.100	HALTEGUMMI FÜR CDI 05	RUBBER HOLDER FOR CDI 05	1
18	580.30.002.050	VERSCHLUSSSCHRAUBE M18X1,5	PLUG M18X1,5	1
20	0015 060163	SK.BUNDSCHRAUBE M 6X16 SW=8	HH COLLAR SCREW M 6X16 WS=8	2
30	590.39.093.100	ZÜNDKERZE NGK DCPR8E 03	SPARK PLUG NGK DCPR8E 03	1
31	584.39.090.000	ZÜNDKERZENSTECKER SD05EG 03	SPARK PLUG CONNECT. SD05EG 03	1
32	0015 060253	SK.BUNDSCHRAUBE M 6X25 SW=8	HH COLLAR SCREW M 6X25 WS=8	3
33	0015 060303	SK.BUNDSCHRAUBE M 6X30 SW=8	HH COLLAR SCREW M 6X30 WS=8	1
34	0125 060003	UNTERLEGSCHLEIBE DIN 125 A 6,4	WASHER DIN0125-A 6,4	4

05-584.39.1

05-584.39.1

* NEUTEIL / NEW PART X NACH BEDARF / AS REQUIRED

ELEKTROSTARTER » *ELECTRIC STARTER*

625/640 / 2005

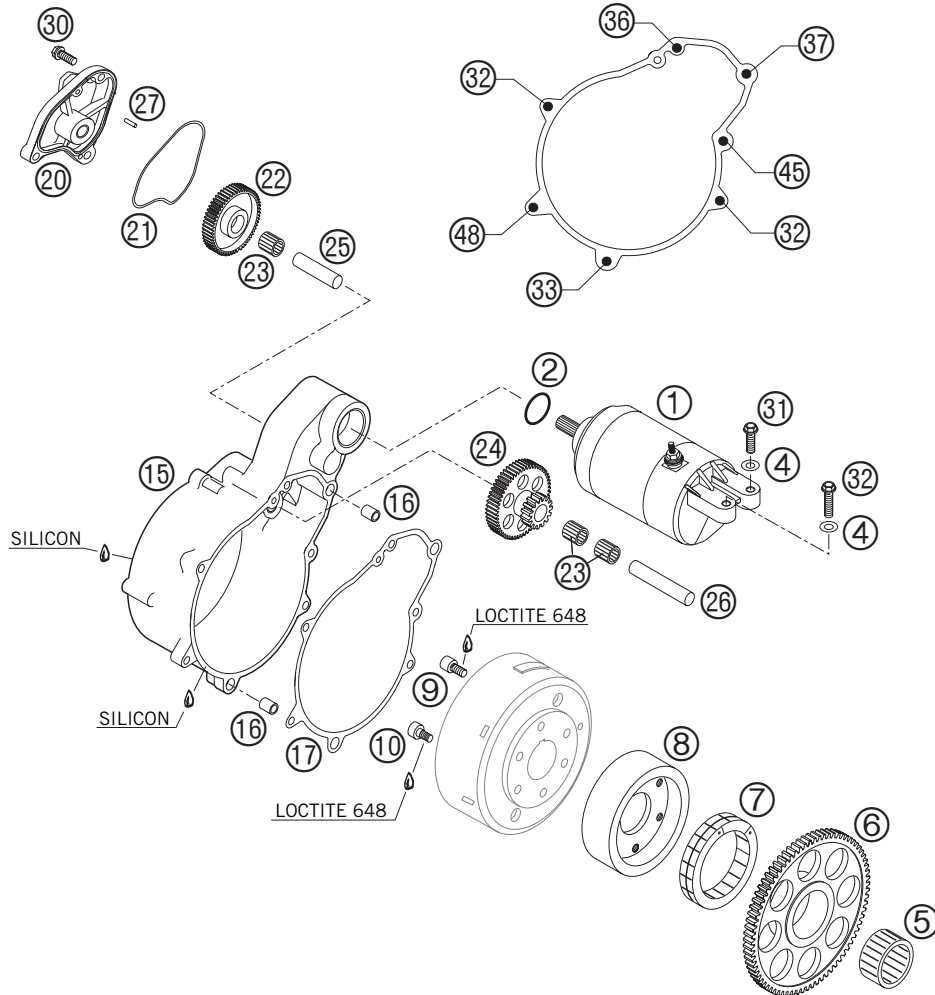
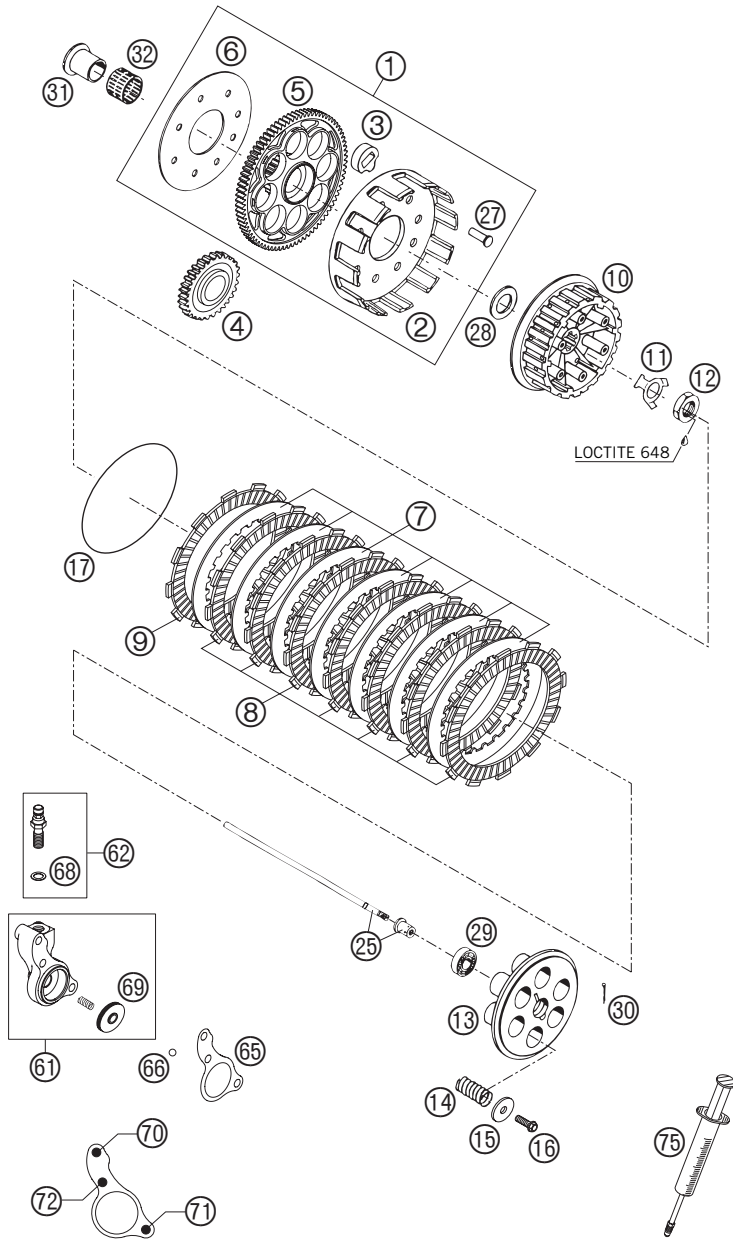

FIG	TEILNR/PARTNR	BEZEICHNUNG	DESCRIPTION	QTY
1	584.40.001.000	E-STARTERMOTOR KPL. LC4-E	E-STARTER ENGINE CPL. LC4-E	1
2	0770 250030	O-RING 25,00X3,00 NBR 70	O-RING 25,00X3,00 NBR 70	1
4	0125 060003	UNTERLEGSCHIEBE DIN 125 A 6,4	WASHER DIN0125-A 6,4	2
5	584.40.090.100	NADELKRANZ K30 X 37 X 18 A	NEEDLE BEARING K30 X 37 X 18 A	1
6	584.40.020.079	FREILAUFZAHNRAD 79-Z	FREE-WHEEL-GEAR 79-T	1
7	584.40.026.000	FREILAUF FWD 332008 BLS	FREE-WHEEL FWD 332008 BLS	1
8	584.40.025.000	FREILAUFNABE	FREEWHEEL HUB	1
9	0912 060121	ISK.SCHRAUBE DIN912 M6X12 12.9	AH SCREW DIN0912-M 6X12 12.9	4
10	584.40.098.000	ISK-SCHRAUBE M6X12,5 M. ANSATZ	AH CENTERING SCREW M6X12,5	2
15	584.40.010.100/23	STARTERFLANSCH GRAU '03	STARTER FLANGE GREY 03	1
16	490.30.090.000	PASSHÜLSE 9,8 X 7 X 10	DOWEL 9,8 X 7 X 10	2
17	585.40.042.000	STARTERFLANSCHDICHTG. 0,5MM 01	STARTER FLAN.GASKET 0,5MM 2001	1
20	584.40.011.100/23	STARTERDECKEL GRAU '03	STARTER COVER GREY 03	1
21	584.40.011.050	FORMRING F.STARTERDECKEL NBR70	FORM RING F.STARTERCOVER NBR70	1
22	584.40.022.000	ZWISCHENZAHNRAD 52-Z	INTERMEDIATE GEAR 52-T	1
23	584.40.090.000	NADELKRANZ K10 X 13 X 13 TN	NEEDLE BEARING K10 X 13 X 13TN	3
24	584.40.021.018	DOPPELZAHNRAD 55-Z/18-Z	REDUCTION GEAR 55-T/18-Z	1
25	584.40.028.000	LAGERBOLZEN 10 X 38,4	BEARING BOLT 10 X 38,4	1
26	584.40.029.000	LAGERBOLZEN 10 X 54	BEARING BOLT 10 X 54	1
27	0402 040780	NADELROLLE DIN5402 NRB 4X 7,8	NEEDLEROLL. DIN5402 NRB 4X 7,8	2
30	0015 060163	SK.BUNDSCHRAUBE M 6X16 SW=8	HH COLLAR SCREW M 6X16 WS=8	1
31	0015 060203	SK.BUNDSCHRAUBE M 6X20 SW=8	HH COLLAR SCREW M 6X20 WS=8	1
32	0015 060253	SK.BUNDSCHRAUBE M 6X25 SW=8	HH COLLAR SCREW M 6X25 WS=8	3
33	0015 060303	SK.BUNDSCHRAUBE M 6X30 SW=8	HH COLLAR SCREW M 6X30 WS=8	1
36	0015 060453	SK.BUNDSCHRAUBE M 6X45 SW=8	HH COLLAR SCREW M 6X45 WS=8	1
37	0015 060503	SK.BUNDSCHRAUBE M 6X50 SW=8	HH COLLAR SCREW M 6X50 WS=8	1
45	0015 060803	SK.BUNDSCHRAUBE M 6X80 SW=8	HH COLLAR SCREW M 6X80 WS=8	1
48	0015 060953	SK.BUNDSCHRAUBE M 6X95 SW=8	HH COLLAR SCREW M 6X95 WS=8	1

05-584.40.0

04-583.40.0

* NEUTEIL / NEW PART X NACH BEDARF / AS REQUIRED



05-584.32.0

FIG	TEILNR/PARTNR	BEZEICHNUNG	DESCRIPTION	QTY
1	584.32.001.144	KUPPLUNGSKORB KPL. 79-Z LC4 04	OUT.CLUTCH HUB CPL.79-T LC4 04	1
2	584.32.001.000	KUPPLUNGSKORB LOSE LC4 03	OUTER CLUTCH HUB LOOSE LC4 03	1
3	583.32.026.000	DÄMPFUNGSELEMENT '94	DAMPING ELEMENT '94	8
4	585.32.000.131	PRIMÄRRAD 31 Z 2001	PRIMARY GEAR WHEEL 31-T 2001	1
5	585.32.000.079	KUPPLUNGSRAD 79Z 2001	CLUTCH WHEEL 79-T 2001	1
6	583.32.028.000	HALTEBLECH 57 X 132 X 1,5 '94	BRACKET 57 X 132 X 1,5 '94	1
7	583.32.112.000	STAHLLELLE 1,5 MM LC4'94	STEEL DISK 1,5 MM LC4'94	7
8	583.32.011.300	BELAGLELLE 2,7MM FCC 02	LINING DISK 2,7MM FCC 02	7
9	583.32.111.300	BELAGLELLE AUSGEDREHT FCC 02	LINING DISK TURN OUT FCC 02	1
10	583.32.002.300	MITNEHMER LC4/LC4-E 04	INNER CLUTCH HUB LC4/LC4-E 04	1
11	583.32.018.000	SICHERUNGSBLECH '94	LOCK WASHER '94	1
12	0936 181505	SK.MUTTER DIN0936-M18X1,5 RE.	HEXAGON NUT DIN0936-M18X1,5 R.	1
13	583.32.003.300	DRUCKKAPPE LC4/LC4-E 04	PRESSURE CAP LC4/LC4-E 04	1
14	583.32.080.000	KUPPLUNGSFEDER 2,8 X 37	CLUTCH SPRING 2,8 X 37	6
15	584.32.081.000	STUFENSCHLEIBE 6,5 X 20 X 2	WASHER 6,5 X 20 X 2	6
16	0015 060203	SK.BUNDSCHRAUBE M 6X20 SW=8	HH COLLAR SCREW M 6X20 WS=8	6
17	0770 116030	O-RING 116,00X3,00 HNBR 70	O-RING 116,00X3,00 HNBR 70	1
25	573.32.017.044	DRUCKSTANGE L=215MM KPL. MIT AUFLAGEBOLZEN 03	PUSH ROD L=215MM CPL. WITH PRESSURE BOLT 03	1
27	583.32.007.000	NIET 6 X 23 X 11,2	RIVET 6 X 23 X 11,2	8
28	575.32.013.000	STÜTZSCHEIBE 22,2X35X3 GEHÄRT.	SUPPORTWASHER 22,2X35X3 HARDE.	1
29	0625 060016	RILLENKUGELLAGER 6001.2RSR C3	GROOV.BALL BEAR. 6001.2RSR C3	1
30	0094 020163	SPLINT DIN0094-2,0X16	PIN DIN0094-2,0X16	1
31	503.32.070.000	INNENRING MIT BUND	INNER RING WITH COLLAR	1
32	565.32.095.000	NADELKRANZ K 26X30X22 ZW.KSE	NEEDLE BEARING K26X30X22ZW.KSE	1
61	503.32.061.044	NEHMERZYLINDER KPL. 125/200'98	CYLINDER CPL. 125/200'98	1
62	503.32.062.000	HOHLSCHRAUBE KPL. M 10X1 '98	HOLLOW SCREW CPL. M 10X1 '98	1
65*	586.32.065.000	DICHTUNG F.HYDR.KUPPLUNGS-AUSR.	CLUTCH RELEASE GASKET	1
66	0401 070003	KUGEL DIN5401-7	BALL DIN5401-7	1
68	420.13.226.000	CU-DICHRING DIN7603-10X16X1	CU-SEAL RING DIN7603-10X16X1	1
69	503.32.066.000	KOLBEN MIT O-RING 125/200 2000	PISTON W. O-RING 125/200 2000	1
70	0912 060303	ISK.SCHRAUBE DIN 912 M6X30	AH SCREW DIN0912-M 6X30	1
71	0984 060163	ISK.SCHRAUBE DIN6912-M 6X16 MIT NIEDRIGEM KOPF	AH SCREW DIN6912-M 6X16 WITH LOW HEAD	1
72	0912 060253	ISK.SCHRAUBE DIN 912 M6X25	AH SCREW DIN0912-M 6X25	1
75	503.29.050.000	ENTLÜFT.SPITZE HYDR. KUPPLUNG	VENT INJEKTION HYDR. CLUTCH	1

05-584.32.0

* NEUTEIL / NEW PART X NACH BEDARF / AS REQUIRED

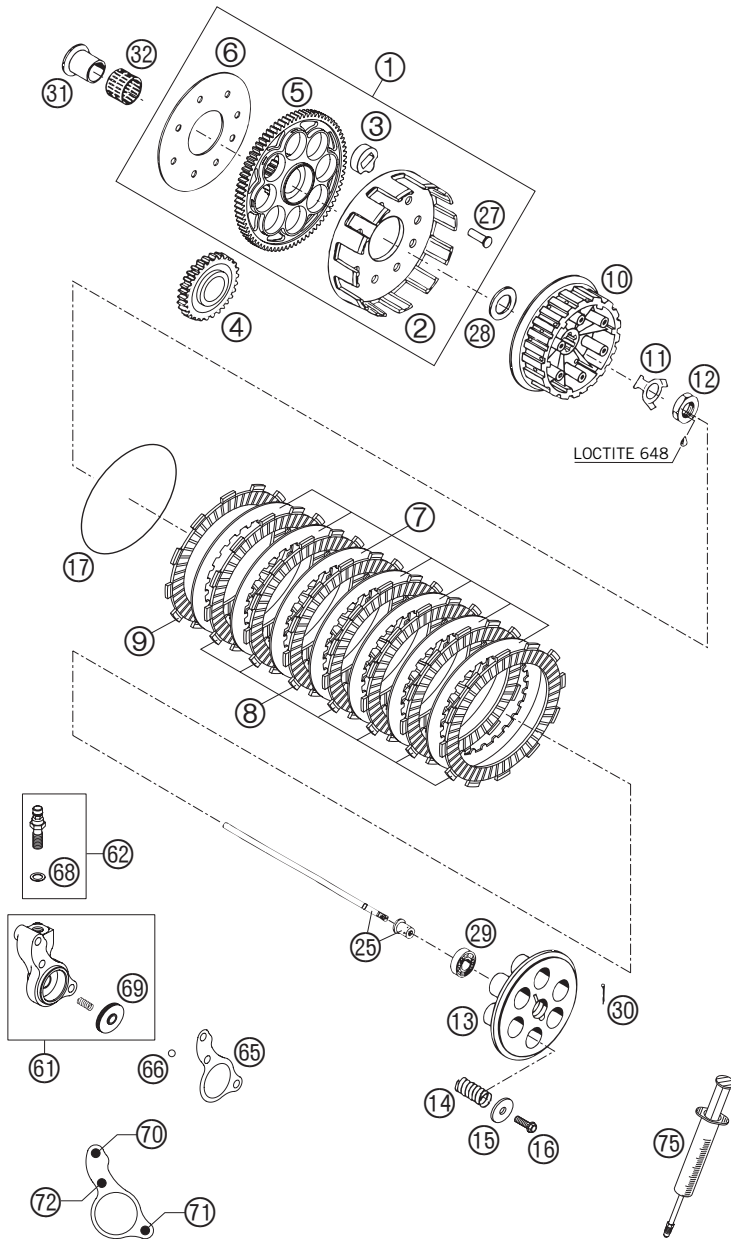

05-584.32.0

FIG	TEILNR/PARTNR	BEZEICHNUNG	DESCRIPTION	QTY
1	584.32.001.144	KUPPLUNGSKORB KPL. 79-Z LC4 04	OUT.CLUTCH HUB CPL.79-T LC4 04	1
2	584.32.001.000	KUPPLUNGSKORB LOSE LC4 03	OUTER CLUTCH HUB LOOSE LC4 03	1
3	583.32.026.000	DÄMPFUNGSELEMENT '94	DAMPING ELEMENT '94	8
4	585.32.000.131	PRIMÄRRAD 31 Z 2001	PRIMARY GEAR WHEEL 31-T 2001	1
5	585.32.000.079	KUPPLUNGSRAD 79Z 2001	CLUTCH WHEEL 79-T 2001	1
6	583.32.028.000	HALTEBLECH 57 X 132 X 1,5 '94	BRACKET 57 X 132 X 1,5 '94	1
7	583.32.112.000	STAHLLELLE 1,5 MM LC4'94	STEEL DISK 1,5 MM LC4'94	7
8	583.32.011.300	BELAGLELLE 2,7MM FCC 02	LINING DISK 2,7MM FCC 02	7
9	583.32.111.300	BELAGLELLE AUSGEDREHT FCC 02	LINING DISK TURN OUT FCC 02	1
10	583.32.002.300	MITNEHMER LC4/LC4-E 04	INNER CLUTCH HUB LC4/LC4-E 04	1
11	583.32.018.000	SICHERUNGSBLECH '94	LOCK WASHER '94	1
12	0936 181505	SK.MUTTER DIN0936-M18X1,5 RE.	HEXAGON NUT DIN0936-M18X1,5 R.	1
13	583.32.003.300	DRUCKKAPPE LC4/LC4-E 04	PRESSURE CAP LC4/LC4-E 04	1
14	585.32.080.000	KUPPLUNGSFEDER 3,0X33,5	CLUTCHSPRING 3,0X33,5	6
15	584.32.081.000	STUFENSCHLEIBE 6,5 X 20 X 2	WASHER 6,5 X 20 X 2	6
16	0015 060203	SK.BUNDSCHRAUBE M 6X20 SW=8	HH COLLAR SCREW M 6X20 WS=8	6
17	0770 116030	O-RING 116,00X3,00 HNBR 70	O-RING 116,00X3,00 HNBR 70	1
25	573.32.017.044	DRUCKSTANGE L=215MM KPL. 03 MIT AUFLAGEBOLZEN	PUSH ROD L=215MM CPL. 03 WITH PRESSURE BOLT	1
27	583.32.007.000	NIET 6 X 23 X 11,2	RIVET 6 X 23 X 11,2	8
28	575.32.013.000	STÜTZSCHEIBE 22,2X35X3 GEHÄRT.	SUPPORTWASHER 22,2X35X3 HARDE.	1
29	0625 060016	RILLENKUGELLAGER 6001.2RSR C3	GROOV.BALL BEAR. 6001.2RSR C3	1
30	0094 020163	SPLINT DIN0094-2,0X16	PIN DIN0094-2,0X16	1
31	503.32.070.000	INNENRING MIT BUND	INNER RING WITH COLLAR	1
32	565.32.095.000	NADELKRANZ K 26X30X22 ZW.KSE	NEEDLE BEARING K26X30X22ZW.KSE	1
61	503.32.061.044	NEHMERZYLINDER KPL. 125/200'98	CYLINDER CPL. 125/200'98	1
62	503.32.062.000	HOHLSCHRAUBE KPL. M 10X1 '98	HOLLOW SCREW CPL. M 10X1 '98	1
65*	586.32.065.000	DICHTUNG F.HYDR.KUPPLUNGS-AUSR.	CLUTCH RELEASE GASKET	1
66	0401 070003	KUGEL DIN5401-7	BALL DIN5401-7	1
68	420.13.226.000	CU-DICHRING DIN7603-10X16X1	CU-SEAL RING DIN7603-10X16X1	1
69	503.32.066.000	KOLBEN MIT O-RING 125/200 2000	PISTON W. O-RING 125/200 2000	1
70	0912 060303	ISK.SCHRAUBE DIN 912 M6X30	AH SCREW DIN0912-M 6X30	1
71	0984 060163	ISK.SCHRAUBE DIN6912-M 6X16 MIT NIEDRIGEM KOPF	AH SCREW DIN6912-M 6X16 WITH LOW HEAD	1
72	0912 060253	ISK.SCHRAUBE DIN 912 M6X25	AH SCREW DIN0912-M 6X25	1
75	503.29.050.000	ENTLÜFT.SPITZE HYDR. KUPPLUNG	VENT INJEKTION HYDR. CLUTCH	1

05-584.32.1

* NEUTEIL / NEW PART X NACH BEDARF / AS REQUIRED

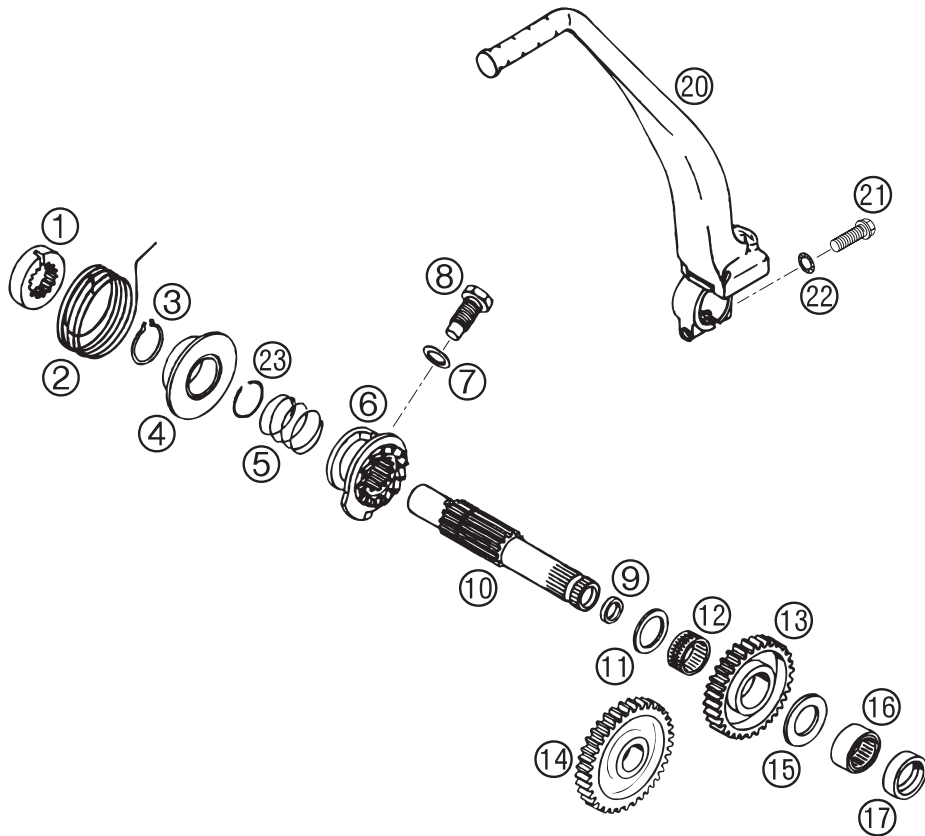

FIG	TEILNR/PARTNR	BEZEICHUNG	DESCRIPTION	QTY
1	580.33.026.200	MITNEHMERNABE '94	DRIVING HUB '94	1
2	580.33.020.000	STARTERFEDER	KICKSTARTER SPRING	1
3	520.33.096.000	SICH.RING DIN0471-25X1,64SD	LOCK RING DIN0471-25X1,64SD	1
4	580.33.037.000	FEDERFÜHRUNG	SPRING BUSHING	1
5	580.33.028.000	SPERRADFEDER 1,2 MM	RATCHET GEAR SPRING 1,2 MM	1
6	580.33.023.200	SPERRRAD 24-Z	RATCHET GEAR 24-T	1
7	580.38.022.000	CU-DICHRING DIN7603-12X18X1,5	CU-SEAL RING DIN7603-12X18X1,5	1
8	580.33.033.000	ANSCHLAGSCHRAUBE M12X1,5	STOP SCREW M12X1,5	1
9	546.32.090.000	DICHRING DH/GR 12X16X3	SEAL RING DH/GR 12X16X3	1
10	580.33.021.300	KICKSTARTERWELLE '94	KICKSTARTER SHAFT '94	1
11	580.33.031.000	ANLAUFSCHIBE 22,2 X 30 X 1,5	STOP DISK 22,2 X 30 X 1,5	1
12	565.33.098.000	NADELKRANZ K22X26X13H	NEEDLE BEARING K22X26X13H	1
13	580.33.022.700	STARTERRAD 35-Z SPERRVERZÄHNUNG 24-Z	KICKSTARTER GEAR 35-T LOCKING TOOTH 24-T	1
14	580.33.024.000	STARTERZWISCHENRAD 37-Z	INTERMEDIATE GEAR 37-T	1
15	565.32.012.000	ANLAUFSCHIBE 22,2 X 35 X 2	STOP DISK 22,2 X 35 X 2	1
16	580.33.090.000	NADELLAGER RNA 4903	NEEDLE BEARING RNA 4903	1
17	0760 223270	WELLENDICHRING 22X32X7 BSL	SHAFT SEAL RING 22X32X7 BSL	1
20	583.33.036.044	KICKSTARTER KPL. ALU LC4'94	KICKSTARTER CPL. ALU LC4'94	1
21	0015 080253	SK.BUNDSCHRAUBE M 8X25 SW=10	HH COLLAR SCREW M 8X25 WS=10	1
22	360.03.014.000	SCHNORR-SICHERUNGSSCHIBE 8MM	LOCK WASHER 8MM	1
23	520.33.090.100	SPRENGRING 25X1,2	LOCK RING 25X1,2	1

02-584.33.4

02-584.33.4

* NEUTEIL / NEW PART X NACH BEDARF / AS REQUIRED

GETRIEBE I - ANTRIEBSWELLE » TRANSMISSION I - MAIN SHAFT

625-660 / 2005

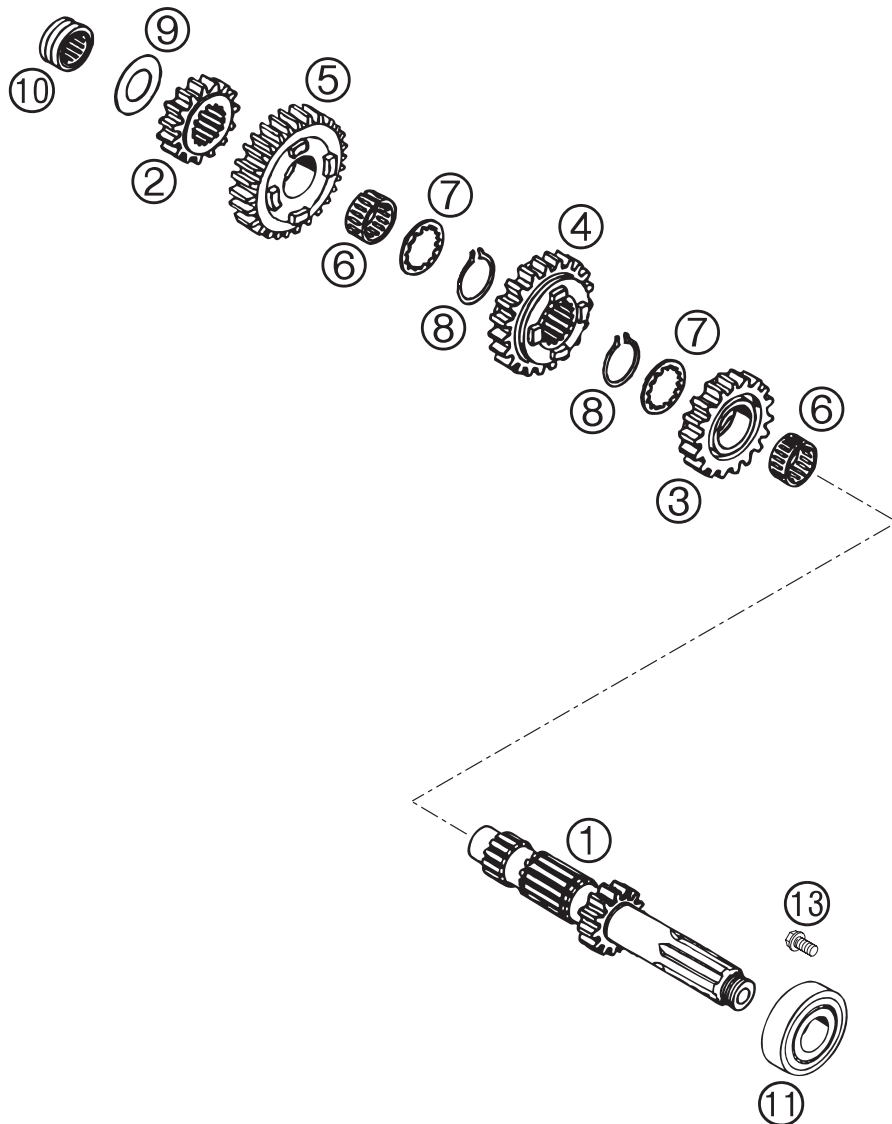

FIG	TEILNR/PARTNR	BEZEICHNUNG	DESCRIPTION	QTY
1	583.33.002.100	ANTRIEBSWELLE 14-Z '96	MAIN SHAFT 14-T '96	1
2	565.33.010.300	FESTRAD 2.G 15-Z (2G3)	SOLID GEAR 2.G 15-T (2G3)	1
3	583.33.004.002	LOSRAD 3.G 18-Z "02"	IDLER GEAR 3.G 18-T "02"	1
4	583.33.006.004	SCHIEBERAD 4.G 20-Z "04"	SLIDING GEAR 4.G 20-T "04"	1
5	583.33.008.008	LOSRAD 5.G 22-Z "08"	IDLER GEAR 5.G 22-T "08"	1
6*	0405 222613	NADELKRANZ K 22X26X13 TN	NEEDLE BEAR. K 22X26X13 TN	2
7	565.33.016.300	ANLAUFSCHEIBE 22,7 X 32 X 1,5	STOP DISK 22,7 X 32 X 1,5	2
8	520.33.096.000	SICH.RING DIN0471-25X1,64SD	LOCK RING DIN0471-25X1,64SD	2
9	565.33.015.000	ANLAUFSCHEIBE 20,2 X 35 X 1	STOP DISK 20,2 X 35 X 1	1
10	565.33.093.000	NADELLAGER RNA 4902 KSE	NEEDLE BEARING RNA 4902 KSE	1
11	585.33.025.000	ZYL.ROLLENLAGER BC1-0076A	CYL.ROLL BEARING BC1-0076A	1
13	0015 060123	SK.BUNDSCHRAUBE M 6X12 SW=8	HH COLLAR SCREW M 6X12 WS=8	1

03-583.33.0

05-584.33.0

* NEUTEIL / NEW PART X NACH BEDARF / AS REQUIRED

GETRIEBE II - ABTRIEBSWELLE » TRANSMISSION II - COUNTER SHAFT

625/640 / 2005

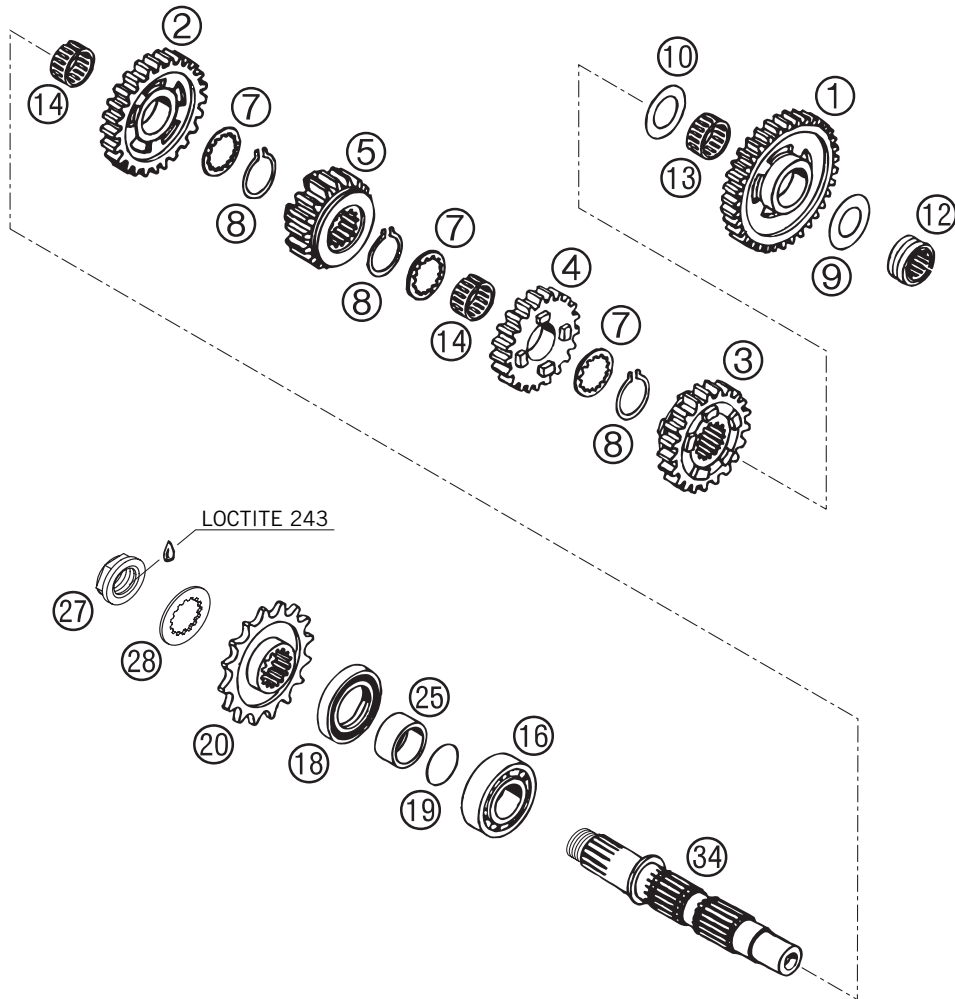

05-584.33.1

05-584.33.1

FIG	TEILNR/PARTNR	BEZEICHNUNG	DESCRIPTION	QTY
1	565.33.005.300	LOSRAD 1.G 35-Z (1M3)	IDLER GEAR 1.G 35-T (1M3)	1
2	583.33.113.010	LOSRAD 2.G 24-Z "10"	IDLER GEAR 2.G 24-T "10"	1
3	583.33.007.003	SCHIEBERAD 3.G 21-Z "03"	SLIDING GEAR 3.G 21-T "03"	1
4	583.33.009.005	LOSRAD 4.G 19-Z "05"	IDLER GEAR 4.G 19-T "05"	1
5	583.33.011.009	SCHIEBERAD 5.G 18-Z "09"	SLIDING GEAR 5.G 18-T "09"	1
7	565.33.016.300	ANLAUFSCHIEBE 22,7 X 32 X 1,5	STOP DISK 22,7 X 32 X 1,5	3
8	520.33.096.000	SICH.RING DIN0471-25X1,64SD	LOCK RING DIN0471-25X1,64SD	3
9	565.33.015.000	ANLAUFSCHIEBE 20,2 X 35 X 1	STOP DISK 20,2 X 35 X 1	1
10	565.33.018.300	ANLAUFSCHIEBE 22,2 X 35 X 1,5	STOP DISK 22,2 X 35 X 1,5	1
12	565.33.093.000	NADELLAGER RNA 4902 KSE	NEEDLE BEARING RNA 4902 KSE	1
13	565.33.098.000	NADELKRAZ K22X26X13H	NEEDLE BEARING K22X26X13H	1
14*	0405 222613	NADELKRAZ K 22X26X13 TN	NEEDLE BEAR. K 22X26X13 TN	2
16	490.30.023.000	ZYLINDERROLLENLAG. NJ205	CYL.ROLL BEARING NJ205	1
18	0760 324771	WELLENDICHRING 32X47X7 BSL	SHAFT SEAL RING 32X47X7 BSL	1
19	0770 250021	O-RING 25,00X2,00 SILICON	O-RING 25,00X2,00 SILICONE	1
20	580.33.029.014	KETTENRAD 14 Z	ENGINE SPROCKET 14 T	X
20	580.33.029.015	KETTENRAD 15 Z	ENGINE SPROCKET 15 T	X
20	580.33.029.016	KETTENRAD 16 Z	ENGINE SPROCKET 16 T	X
20	580.33.029.017	KETTENRAD 17 Z	ENGINE SPROCKET 17 T	X
25	546.33.014.100	DISTANZBÜCHSE 12MM	SPACER BUSHING 12MM	1
27	580.33.032.200	KETTENRADMUTTER LC4	SPROCKET NUT LC4	03
28	510.33.031.000	SICHERUNGSBLECH	LOCK WASHER	1
34	583.33.003.100	ABTRIEBSWELLE	COUNTERSHAFT	03

* NEUTEIL / NEW PART X NACH BEDARF / AS REQUIRED

GETRIEBE II - ABTRIEBSWELLE » TRANSMISSION II - COUNTER SHAFT

660 / 2005

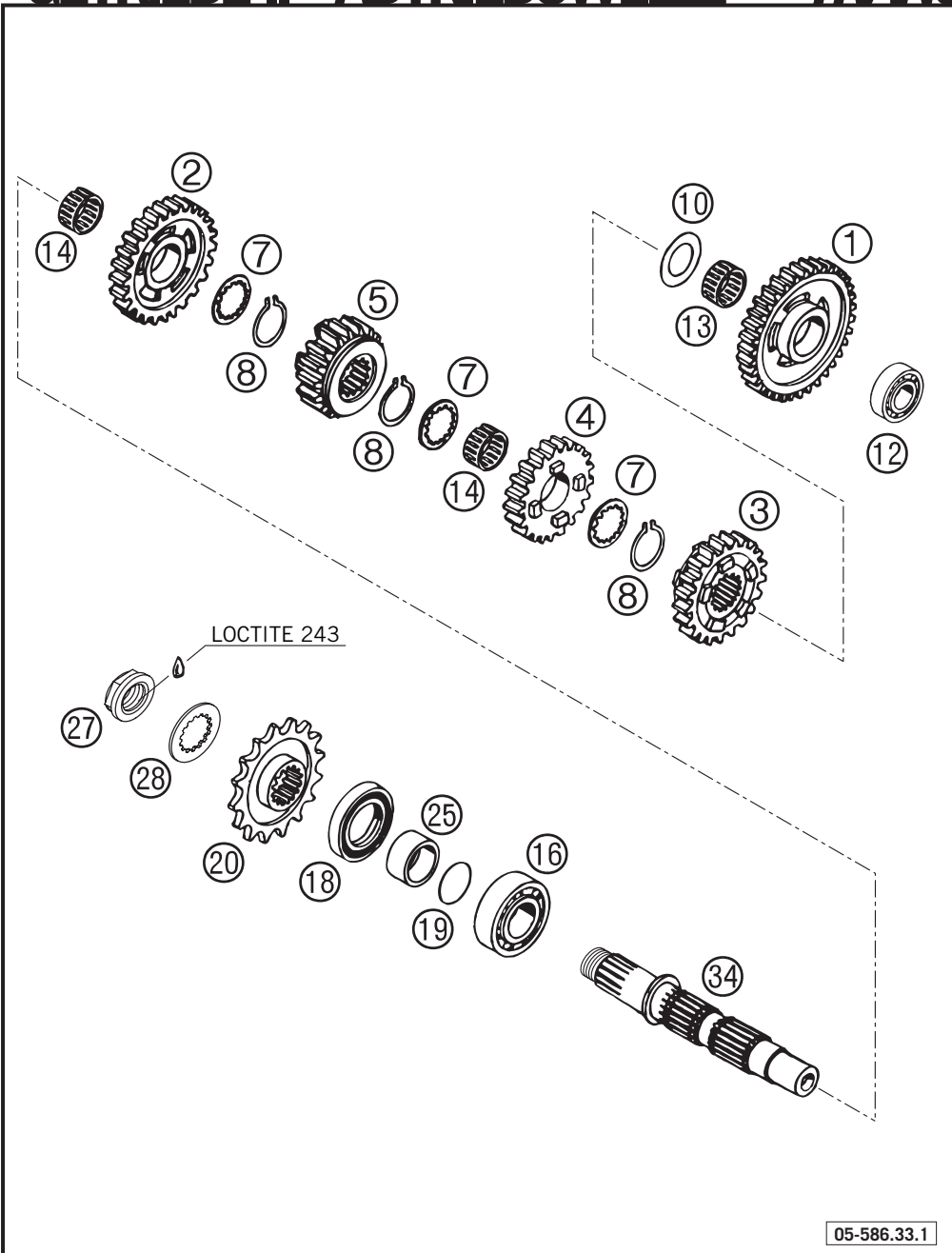

FIG	TEILNR/PARTNR	BEZEICHNUNG	DESCRIPTION	QTY
1	565.33.005.300	LOS RAD 1.G 35-Z (1M3)	IDLER GEAR 1.G 35-T (1M3)	1
2	583.33.113.010	LOS RAD 2.G 24-Z "10"	IDLER GEAR 2.G 24-T "10"	1
3	583.33.007.003	SCHIEBERAD 3.G 21-Z "03"	SLIDING GEAR 3.G 21-T "03"	1
4	583.33.009.005	LOS RAD 4.G 19-Z "05"	IDLER GEAR 4.G 19-T "05"	1
5	583.33.011.009	SCHIEBERAD 5.G 18-Z "09"	SLIDING GEAR 5.G 18-T "09"	1
7	565.33.016.300	ANLAUFSCHLEIBE 22,7 X 32 X 1,5	STOP DISK 22,7 X 32 X 1,5	3
8	520.33.096.000	SICH.RING DIN0471-25X1,64SD	LOCK RING DIN0471-25X1,64SD	3
10	565.33.018.300	ANLAUFSCHLEIBE 22,2 X 35 X 1,5	STOP DISK 22,2 X 35 X 1,5	1
12	0412 303914	ZYL.ROLLENLAGER NJ204ECP/C3	CYL.ROLL BEARING NJ204ECP/C3	1
13	565.33.098.000	NADELKRANZ K22X26X13H	NEEDLE BEARING K22X26X13H	1
14*	0405 222613	NADELKRANZ K 22X26X13 TN	NEEDLE BEAR. K 22X26X13 TN	2
16	490.30.023.000	ZYLINDERROLLENLAG. NJ205	CYL.ROLL BEARING NJ205	1
18	0760 324771	WELLENDICHRING 32X47X7 BSL	SHAFT SEAL RING 32X47X7 BSL	1
19	0770 250021	O-RING 25,00X2,00 SILICON	O-RING 25,00X2,00 SILICONE	1
20	580.33.029.014	KETTENRAD 14 Z	ENGINE SPROCKET 14 T	X
20	580.33.029.015	KETTENRAD 15 Z	ENGINE SPROCKET 15 T	X
20	580.33.029.016	KETTENRAD 16 Z	ENGINE SPROCKET 16 T	X
20	580.33.029.017	KETTENRAD 17 Z	ENGINE SPROCKET 17 T	X
25	546.33.014.100	DISTANZBÜCHSE 12MM	SPACER BUSHING 12MM	1
27	580.33.032.200	KETTENRADMUTTER LC4	SPROCKET NUT LC4	03
28	510.33.031.000	SICHERUNGSBLECH	LOCK WASHER	1
34	583.33.003.100	ABTRIEBSWELLE	COUNTERSHAFT	03

05-586.33.1

05-586.33.1

* NEUTEIL / NEW PART X NACH BEDARF / AS REQUIRED

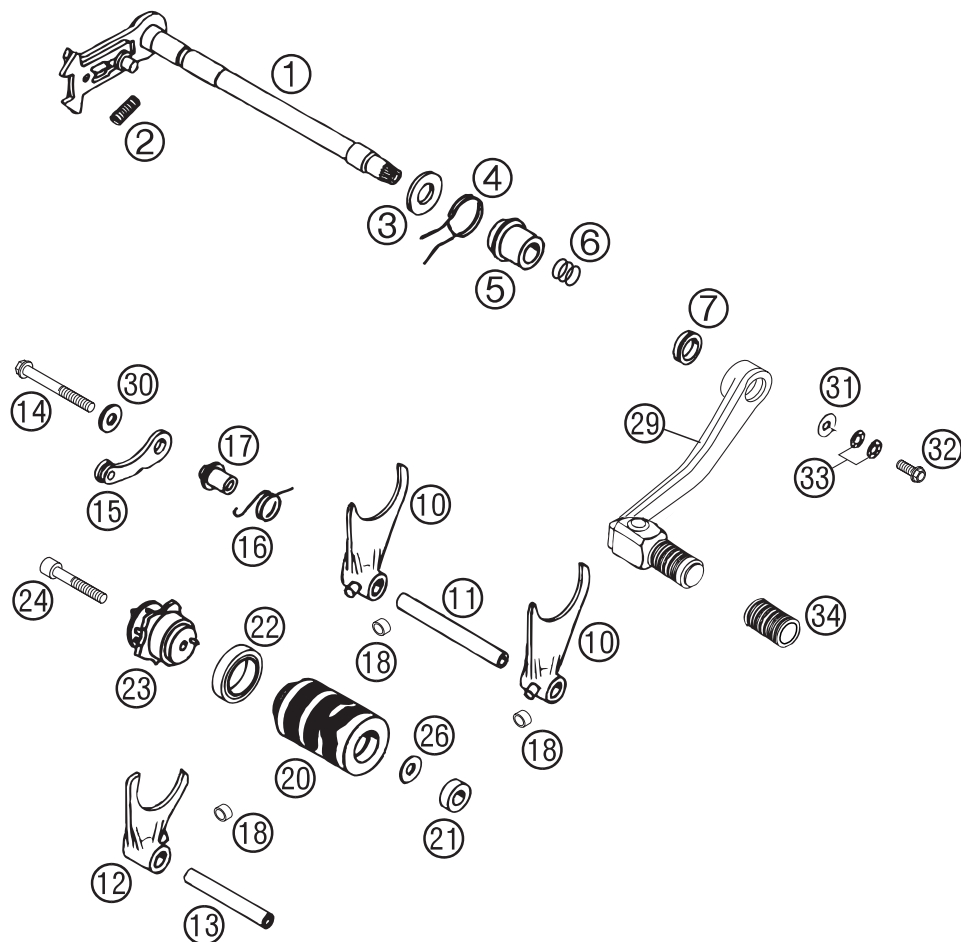

FIG	TEILNR/PARTNR	BEZEICHNUNG	DESCRIPTION	QTY
1	583.34.005.044	SCHALTWELLE KPL. LC4'94	SHIFT SHAFT CPL. LC4'94	1
2	565.34.013.100	SPANNFEDER 0,8MM	TENSIONING SPRING 0,8MM	1
3	580.34.010.000	STAHSCHIBE 14 X 28 X 2	STEEL WASHER 14 X 28 X 2	1
4	580.34.014.000	RÜCKHOLFEDER	RETURN SPRING	1
5	583.34.020.000	FEDERHÜLSE	SPRING SLEEVE	1
6	0770 125020	O-RING 12,50X2,00 NBR 70	O-RING 12,50X2,00 NBR 70	2
7	580.33.027.000	V-DICHTRING V-14-A	V-SEAL RING V-14-A	1
10	580.34.002.300	SCHALTGABEL 1./4.U.2.GANG '98	SHIFT FORK 1ST/4TH+2ND GEAR'98	2
11	580.34.004.000	SCHALTSCHIENE 1./4. U. 2.GANG	SHIFT RAIL 1ST/4TH + 2ND GEAR	1
12	580.34.001.300	SCHALTGABEL 3./5. GANG '98	SHIFT FORK 3RD/5TH GEAR '98	1
13	580.34.003.000	SCHALTSCHIENE 3./5. GANG	SHIFT RAIL 3RD/5TH GEAR	1
14	0015 060653	SK.BUNDSCHRAUBE M 6X65 SW=8	HH COLLAR SCREW M 6X65 WS=8	1
15	583.34.024.044	ARRETIERHEBEL KPL. '94	LOCKING LEVER CPL. '94	1
16	580.34.023.500	ARRETIERHEBELFEDER	SPRING	1
17	583.34.017.000	ARRETIERFEDERHÜLSE	SPRING SLEEVE	1
18	503.34.018.100	SCHALTROLLE 6X8X5,2	SHIFTING ROLLER 6X8X5,2	3
20	583.34.012.000	SCHALTWALZE STAHL	SHIFT ROLLER STEEL	1
21	0625 006087	RILLENKUGELLAGER 608 2RS C3	GROOVED BALL BEAR. 608 2RS C3	1
22	0625 618050	RILLENKUGELLAGER 61805 C3	BALL BEARING 61805 C3	1
23	584.34.015.044	SCHALTARRETIERUNG KPL. LC4 '98	SHIFT LOCATING DRUM CPL. '98	1
24	0912 060404	ISK.SCHRAUBE DIN0912-M 6X40 A2	AH SCREW DIN0912-M 6X40 A2	1
26	510.06.097.000	SCHEIBE 6,2X22X1,ST30,W.VERZ.	WASHER 6,2X22X1,ST30,W.GALV.	1
29	584.34.031.144	SCHALTHEBEL KPL. LC4,COMP. '98	SHIFT LEVER CPL. LC4,COMP. '98	1
30	502.32.050.000	STAHSCHIBE 6,2X18X2	WASHER 6,2X18X2	1
31	502.32.050.001	STAHSCHIBE 6,4X17X3	STEEL WASHER 6,4X17X3	1
32	0015 060163	SK.BUNDSCHRAUBE M 6X16 SW=8	HH COLLAR SCREW M 6X16 WS=8	1
33	502.33.041.000	NORDLOCKSCHIBEN M6 (PAAR) DAC	PAIR OF WASHERS M 6 NORDLOCK	1
34	362.05.018.000	TRITTGUMMI	RUBBER	1

03-583.34.0

03-583.34.0

* NEUTEIL / NEW PART X NACH BEDARF / AS REQUIRED

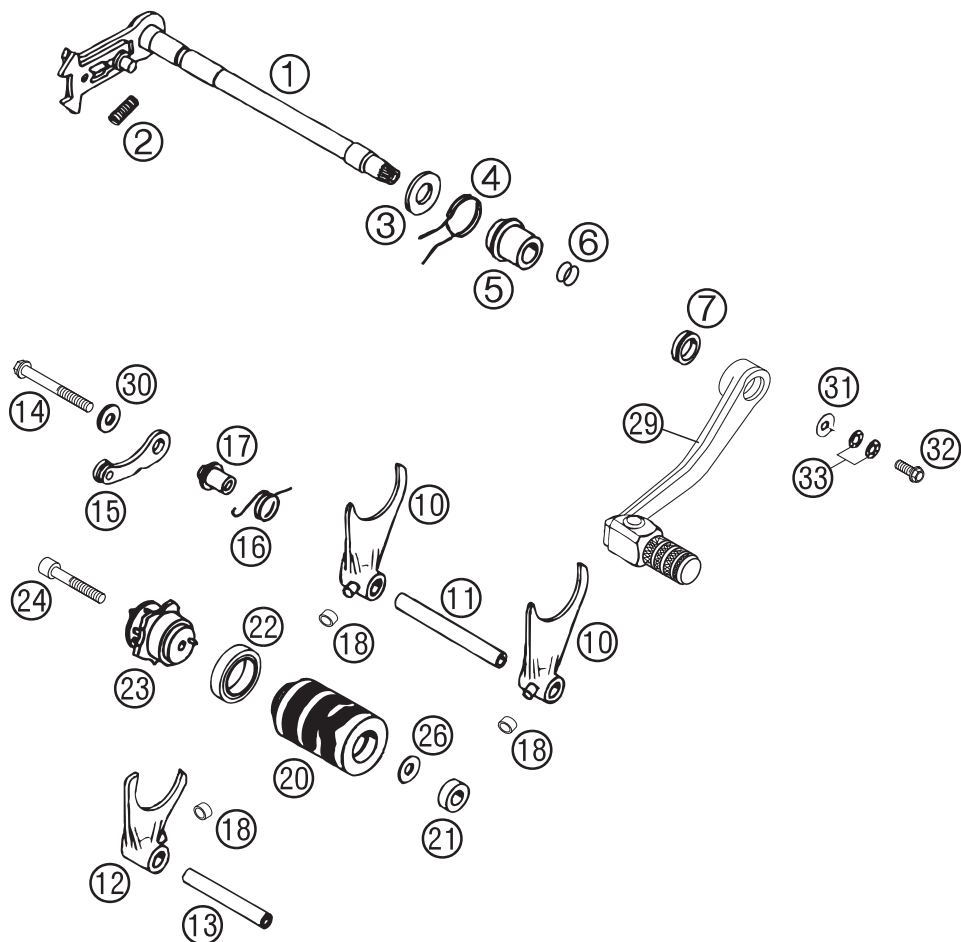

FIG	TEILNR/PARTNR	BEZEICHNUNG	DESCRIPTION	QTY
1	583.34.005.044	SCHALTWELLE KPL. LC4'94	SHIFT SHAFT CPL. LC4'94	1
2	565.34.013.100	SPANNFEDER 0,8MM	TENSIONING SPRING 0,8MM	1
3	580.34.010.000	STAHSCHIBE 14 X 28 X 2	STEEL WASHER 14 X 28 X 2	1
4	580.34.014.000	RÜCKHOLFEDER	RETURN SPRING	1
5	583.34.020.000	FEDERHÜLSE	SPRING SLEEVE	1
6	0770 125020	O-RING 12,50X2,00 NBR 70	O-RING 12,50X2,00 NBR 70	2
7	580.33.027.000	V-DICHTRING V-14-A	V-SEAL RING V-14-A	1
10	580.34.002.300	SCHALTGABEL 1./4.U.2.GANG '98	SHIFT FORK 1ST/4TH+2ND GEAR'98	2
11	580.34.004.000	SCHALTSCHIENE 1./4. U. 2.GANG	SHIFT RAIL 1ST/4TH + 2ND GEAR	1
12	580.34.001.300	SCHALTGABEL 3./5. GANG '98	SHIFT FORK 3RD/5TH GEAR '98	1
13	580.34.003.000	SCHALTSCHIENE 3./5. GANG	SHIFT RAIL 3RD/5TH GEAR	1
14	0015 060653	SK.BUNDSCHRAUBE M 6X65 SW=8	HH COLLAR SCREW M 6X65 WS=8	1
15	583.34.024.044	ARRETIERHEBEL KPL. '94	LOCKING LEVER CPL. '94	1
16	580.34.023.500	ARRETIERHEBELFEDER	SPRING	1
17	583.34.017.000	ARRETIERFEDERHÜLSE	SPRING SLEEVE	1
18	503.34.018.100	SCHALTROLLE 6X8X5,2	SHIFTING ROLLER 6X8X5,2	3
20	583.34.012.000	SCHALTWALZE STAHL	SHIFT ROLLER STEEL	1
21	0625 006087	RILLENKUGELLAGER 608 2RS C3	GROOVED BALL BEAR. 608 2RS C3	1
22	0625 618050	RILLENKUGELLAGER 61805 C3	BALL BEARING 61805 C3	1
23*	584.34.015.044	SCHALTARRETIERUNG KPL. LC4 '98	SHIFT LOCATING DRUM CPL. '98	1
24	0912 060404	ISK.SCHRAUBE DIN0912-M 6X40 A2	AH SCREW DIN0912-M 6X40 A2	1
26	510.06.097.000	SCHEIBE 6,2X22X1,ST30,W.VERZ.	WASHER 6,2X22X1,ST30,W.GALV.	1
29	584.34.031.044	SCHALTHEBEL KPL. SX,SXC,SC '98	SHIFT LEVER CPL. SX,SXC,SC '98	1
30	502.32.050.000	STAHSCHIBE 6,2X18X2	WASHER 6,2X18X2	1
31	502.32.050.001	STAHSCHIBE 6,4X17X3	STEEL WASHER 6,4X17X3	1
32	0015 060163	SK.BUNDSCHRAUBE M 6X16 SW=8	HH COLLAR SCREW M 6X16 WS=8	1
33	502.33.041.000	NORDLOCKSCHIBEN M6 (PAAR) DAC	PAIR OF WASHERS M 6 NORDLOCK	1

03-586.34.0

05-586.34.0

* NEUTEIL / NEW PART X NACH BEDARF / AS REQUIRED

WASSERPUMPE » WATERPUMP

625-660 / 2005

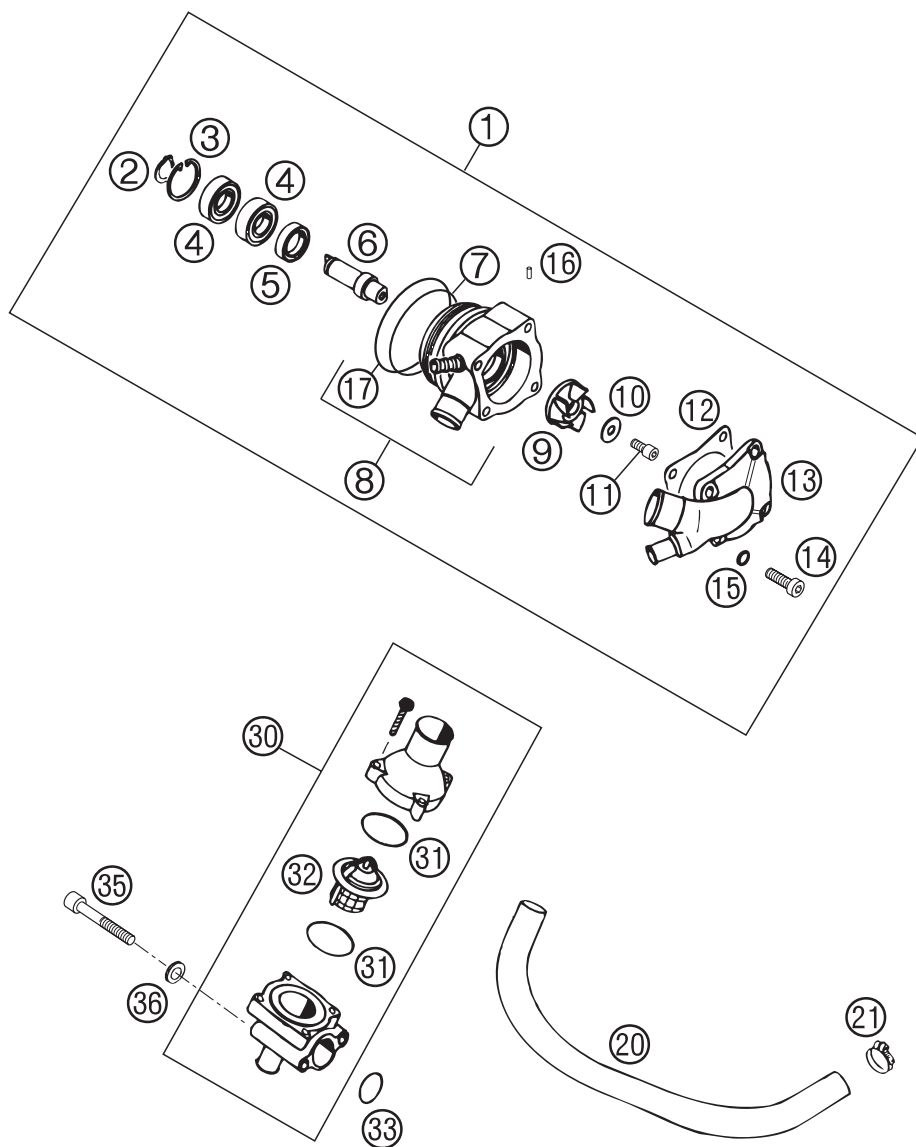

03-583.35.2

05-583.35.2

FIG	TEILNR/PARTNR	BEZEICHNUNG	DESCRIPTION	QTY
1	583.35.050.044	WASSERPUMPE MECHANISCH KPL.'94	WATER PUMP MECHANIC CPL.'94	1
2	0471 120010	SICHERUNGSRING DIN0471-12X1	CIRCLIP DIN0471-12X1	1
3	0472 280120	SICHERUNGSRING DIN0472 28X1,2	CIRCLIP DIN0472-28X1,2	1
4	0625 060016	RILLENKUGELLAGER 6001.2RSR C3	GROOV.BALL BEAR. 6001.2RSR C3	2
5	0760 152472	WELLENDICHTRING 15X24X7 A-DUO	SHAFT SEAL RING 15X24X7 A-DUO	1
6	544.35.010.000	WASSERPUMPENWELLE	WATER PUMP SHAFT	1
7	0770 047015	O-RING 47,00X1,50 NBR 70	O-RING 47,00X1,50 NBR 70	1
8	580.35.002.644	WASSERPUMPENGEHÄUSE KPL. 4T'00	WATER PUMP CASE CPL. 4T '00	1
9	565.35.005.300	WASSERPUMPENRAD	WATER PUMP WHEEL	1
10	0021 050003	SCHEIBE DIN 9021 A 5,3	WASHER DIN9021-A 5,3	1
11	0912 050123	ISK.SCHRAUBE DIN 912 M5X12	AH SCREW DIN0912-M 5X12	1
12	565.35.003.300	PUMPENDECKELDICHUNG	WATER PUMP COVER GASKET	1
13	583.35.001.244	WASSERPUMPENDECKEL LC4 '99	WATER PUMP COVER LC4 '99	1
14	0984 060203	ZYL.SCHRAUBE DIN6912 M6X20 8.8	AH SCREW DIN6912-M 6X20 8.8	4
15	0603 061001	CU-DICHTRING DIN7603-6X10X1	CU-SEAL RING DIN7603-6X10X1	4
16	0402 025580	NADELROLLE DIN5402 NRB 2,5X5,8	NEEDLEROLL.DIN5402 NRB 2,5X5,8	X
17	0770 049025	O-RING 49,00X2,50 NBR	O-RING 49,00X2,50 NBR	1
20*	583.35.025.350	KÜHLER-GEWEBESCHLAUCH 12X3 04	RADIATOR HOSE 12X3 04	0,35
21	583.35.099.000	SCHLAUCHKLEMME GEMI 10-16	HOSE CLAMP GEMI 10-16	2
30	583.35.013.044	THERMOSTAT KPL. 70 GRAD LC4'94	THERMOSTAT CPL. 70 DG LC4'94	1
31	0770 320020	O-RING 32,00X2,00	O-RING 32,00X2,00	2
32	583.35.017.000	THERMOSTAT 70 GRAD '94	THERMOSTAT 70 DEGREES '94	1
33	0770 021020	O-RING 21,00X2,00 NBR70	O-RING 21,00X2,00 NBR70	1
35	0912 060453	ISK.SCHRAUBE DIN 912 M6X45	AH SCREW DIN0912-M 6X45	2
36	0125 060003	UNTERLEGSCHLEIBE DIN 125 A 6,4	WASHER DIN0125-A 6,4	2

* NEUTEIL / NEW PART X NACH BEDARF / AS REQUIRED

KÜHLSYSTEM » COOLING SYSTEM

625-660 / 2005

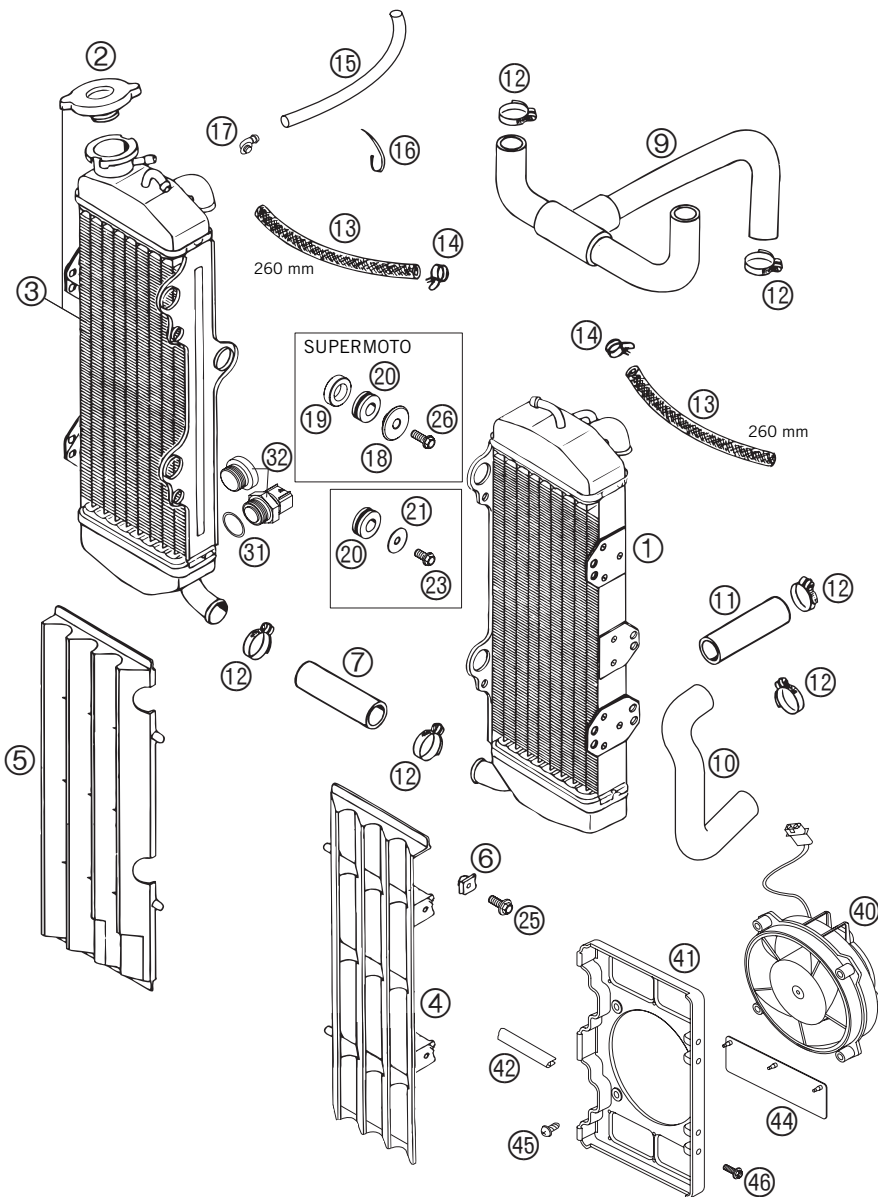

05-584.35.0

FIG	TEILNR/PARTNR	BEZEICHNUNG	DESCRIPTION	QTY
1	583.35.008.000	KÜHLER LINKS (45246) LC4'94 SCHWARZ	RADIATOR L/S (45246) LC4'94 BLACK	1
2	580.35.016.000	KÜHLERVERSCHLUSS KLEIN 1,4 BAR	RADIATOR CAP SMALL 20,3 PSI	1
3	583.35.008.200	KÜHLER RECHTS (45.403) SXC 03 SCHWARZ; OHNE LÜFTERSCHALTER	RADIATOR R/S (45.403) SXC 03 BLACK; WITHOUT FAN SWITCH	1
4	580.35.034.100	KÜHLERSCHUTZ LI. FARBLOS '96	RADIATOR PROTECT. L/S WHITE'96	X
4	580.35.034.000	KÜHLERSCHUTZ LINKS SCHWARZ	RADIATOR PROTECTOR L/S BLACK	1
5	580.35.134.100	KÜHLERSCHUTZ RE. FARBLOS '96	RADIATOR PROTECT. R/S WHITE'96	X
5	580.35.134.000	KÜHLERSCHUTZ RECHTS SCHWARZ	RADIATOR PROTECTOR R/S BLACK	1
6	502.35.033.300	KLIPS-MUTTERNHALTER M6 KP142	SNAP-NUT HOLDER M6 KP142	4
7	565.35.025.001	KÜHLERSCHLAUCH 18X25 PER MET.	RADIATOR HOSE 18X25 PER METRE	0,10
9	583.35.026.000	FORMSCHLAUCH LC4'94	PREFORMED HOSE LC4'94	1
10*	584.35.025.800	FORMSCHLAUCH	PREFORMED HOSE	1
11	583.35.024.001	KÜHLERSCHLAUCH 20X26	RADIATOR HOSE 20X26	0,11
12	100.01.020.000	SCHLAUCHKLEMME GEMI 16-27	HOSE CLAMP GEMI 16-27	9
13	544.35.024.001	ND-SCHLAUCH ID 7,5 PER METER	HOSE ID 7,5 PER METER	0,52
14	580.31.005.000	YDNAC KLAMMER 10128 12MM	CLAMP YDNAC 10128 12MM	4
15	550.07.016.001	SCHLAUCH 7X10 PER METER	PVC-HOSE 7X10 PER METER	0,22
16	440.11.076.200	KABELBAND 200/3,6MM SCHWARZ	CABLE TIE 200/3,6MM BLACK	X
17	503.03.089.000	WINKELSTÜCK '97	ANGEL PIECE '97	1
18	584.35.002.000	BÜCHSE FÜR KÜHLERBEFEST.SM 03	BUSHING F. RADIATOR SUPPORT 03	6
19	584.35.003.000	BÜCHSE FÜR KÜHLERDISTANZ SM 03	BUSHING F. RADIATOR DISTANCE 03	6
20	410.01.052.000	KABELTÜLLE D=12MM	RUBBER SLEEVE D=12MM	6
21	0021 060003	SCHEIBE DIN 9021 A 6,4	WASHER DIN9021-A 6,4	6
23	0015 060123	SK.BUNDSCHRAUBE M 6X12 SW=8	HH COLLAR SCREW M 6X12 WS=8	6
25	0014 060153	SK.BUNDSCHRAUBE M 6X15 SW=8	HH COLLAR SCREW M 6X15 WS=8	4
26	0015 060163	SK.BUNDSCHRAUBE M 6X16 SW=8	HH COLLAR SCREW M 6X16 WS=8	6
31	0770 017015	O-RING 17X1,5 NB75	O-RING 17X1,5 NB75	1
32	584.35.045.098	THERMOSCHALTER 98 °C LÜFTER 03	THERMOSWITCH 98 °C FOR FAN 03	1
32	0908 180153	VERSCHL.SCHR. DIN0908-M18X1,5 625 SXC	PLUG DIN0908-M18X1,5 625 SXC	1
40	584.35.041.000	LÜFTER KPL. 12V LC4 2000	FAN CPL. 12V LC4 2000	1
41	584.35.044.000	LÜFTERHAUBE LC4 2000	FAN CAP LC4 2000	1
42	583.12.085.100	DICHTUNGSPROFIL PER METER	EDGE PROTECTOR PER METER	0,22
44	584.35.044.050	LÜFTERKLAPPE GUMMI LC4 2000	FAN FLAP RUBBER LC4 2000	2
45	0081 500181	SCHRAUBE FÜR KUNSTSTOFF D=5X18	SCREW FOR PLASTIC D=5X18	4
46	0017 060203	EJOT PT SCHRAUBE K60X20 SW=6	EJOT PT SCREW K60X20 WS=6	2

05-584.35.0

* NEUTEIL / NEW PART X NACH BEDARF / AS REQUIRED

HOLZKLOTZ - SELBSTGEFERTIGT
WOODEN BLOCK - HOME MADE

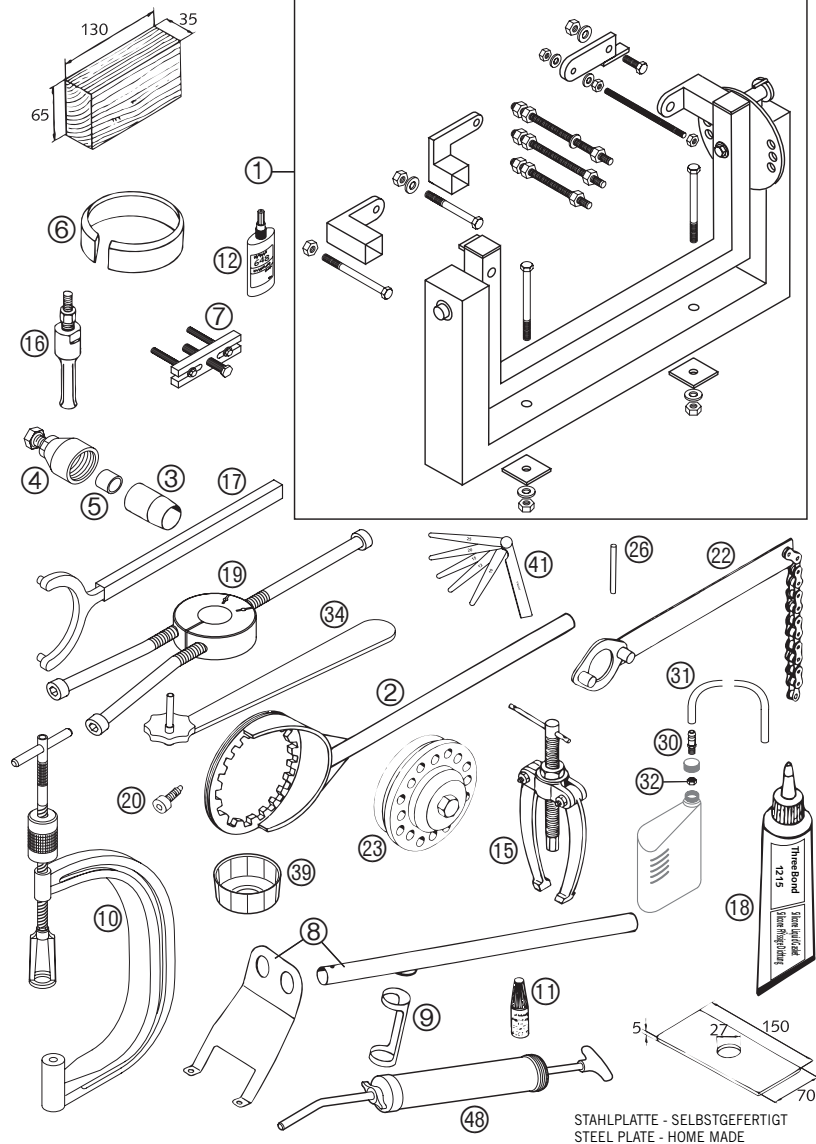

STAHLPLATTE - SELBSTGEFERTIGT
STEEL PLATE - HOME MADE

05-584.29.0

FIG	TEILNR/PARTNR	BEZEICHNUNG	DESCRIPTION	QTY
1	560.12.001.000	UNIVERSALMONTAGEBOCK '96	UNIVERSAL MOUNTING RACK '96	1
2	583.29.003.000	KUPPLUNGSHALTER D=160MM LC4'94	CLUTCH HOLDER D=160MM LC4'94	1
3	580.12.005.025	MONTAGEHÜLSE D=25MM FÜR KURBELW.SIMMERRING LINKS	MOUNTING SLEEVE D=25MM FOR CRANKSHAFT SEAL L/S	1
4	584.29.009.000	SCHWUNGRADABZIEHER	MAGNETO EXTRACTOR	1
5*	510.12.016.000	SCHUTZKAPPE F. KURBELWELLE M12	PROTECTION CAP CRANKSHAFT M12	1
5	584.29.031.000	SCHUTZKAPPE F. KURBELWELLE M16	PROTECTOR CAP F.CRANKSHAFT M16	1
6	580.12.015.101	KOLBEN-MONTAGERING D=101MM 625/640 LC4	PISTON RING COMPRESSOR D=101MM 625/640 LC4	1
6*	585.29.015.102	KOLBEN-MONTAGERING D=102MM 660 LC4	PISTON RING COMPRESSOR D=102MM 660 LC4	1
7	590.29.021.044	ABZIEHER PRIMÄRRAD KPL. MIT M4, M5, M6 SCHRAUBEN	EXTRACTOR PRIM. GEAR CPL. WITH M4, M5, M6 SCREWS	1
8	580.12.019.000	VENTIL-MONTAGEVORRICHTUNG	VALVE INSTALLATION KIT	1
9	6 276 470	VENTILFEDER-SPANNEINSATZ	PUSH INSERT	1
10	590.29.019.000	VENTILFEDERHEBER	VALVE SPRING LEVER	1
11	6 899 785	LOCTITE 243 BLAU 6CCM	LOCTITE 243 BLUE 6CCM	X
12	584.29.059.000	LOCTITE 648 GRÜN 24ML	LOCTITE 648 GREEN 24ML	X
15	151.12.017.000	LAGERAUSZIEHER	BUSHING EXTRACTOR	1
16	151.12.018.000	EINSATZ 12-16 MM	INTERN.BEAR.PULLER 12-16 MM	1
16	151.12.018.100	EINSATZ 18-23 MM	INTERN.BEAR.PULLER 18-23 MM	1
17	584.29.012.000	HALTESCHLÜSSEL F. SCHWUNGRAD	HOLDING WRENCH FOR WHEEL	1
18	309098	SILIKONDICHTMASSE THREE-BOND	SILICON GASKET THREE-BOND	1
19	584.29.037.043	MONTAGEW.F.LAGERINNENR. NJ 207	MOUNTING TOOL F.BEARING NJ 207	1
19	584.29.037.040	MONTAGEW.F.LAGERINNENR. NJ 306	MOUNTING TOOL F.BEARING NJ 306	1
20	580.30.080.000	FIXIERSCHRAUBE M8 L=23	LOCATING SCREW M8 L=23	1
22	510.12.012.000	HALTESCHLÜSSEL F. KETTENRITZEL	HOLDING SPANNER FOR SPROCKET	1
23	546.29.027.000	NIETWERKZEUG FÜR KUPPLUNG	RIVETTING TOOL FOR CLUTCH	1
26	580.29.026.007	GRENZLEHRDORN F. VENTILFÜHRUNG D=7,05 MM	LIMIT PLUG GAUGE F.VALVE GUIDE D=7,05 MM	1
30	590.30.022.000	ENTLÜFTUNGSSTUTZEN M8 SW=10'99	BLEEDER FLANGE M8 WS=10 '99	1
31	310.07.107.001	PVC-SCHLAUCH 6X9 MM PER METER	PVC-HOSE 6X9 MM PER METER	0,3
32	0934 080003	SK.MUTTER DIN 934 M8	HEXAGON NUT DIN0934-M 8	1
34*	590.29.034.000	SCHLÜSSEL GEMISCHREG.SCHRAUBE 660 LC4	WRENCH F.MIXTURE CONTROL SCREW 660 LC4	1
39	583.29.039.000	SCHLÜSSEL FÜR SCHRAUBFILTER	WRENCH SCREW FILTER	1
41	590.29.041.000	FÜHLERLEHNSET 10,12,15,20,25	FEEL. GAUGE SET 10,12,15,20,25	1
48	584.29.048.000	SPRITZE F. RAHMENBRUSTROHR '99 ENTLÜFTEN FÜR RAHMENBRUSTROHR	INJEKTION FOR FRONT PIPE '99 DEAERATE FOR FRONT PIPE	1

05-584.29.0

* NEUTEIL / NEW PART X NACH BEDARF / AS REQUIRED

A large empty rectangular box with a black border, intended for taking notes.

A large empty rectangular box with a black border, intended for taking notes.



KTM-Sportmotorcycle AG
A-5230 Mattighofen
www.ktm.at

KTM Group Partner



3208175

