





50 SX JUNIOR USA 2008

SPARE PARTS MANUAL: CHASSIS

ART.NO.: 3CF6001H3EN

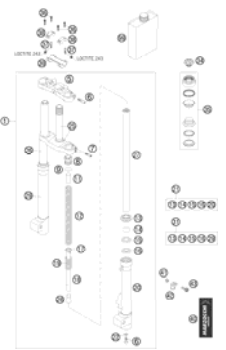
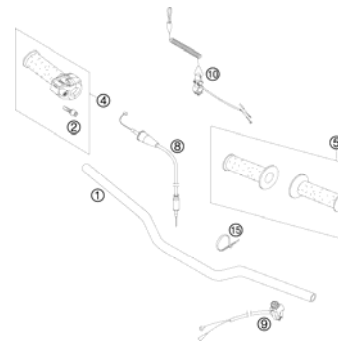
ENGLISH

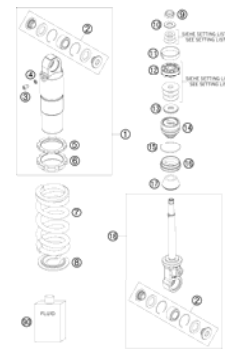
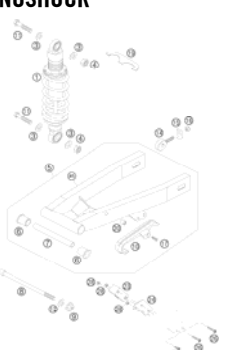
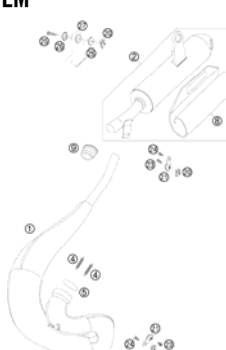
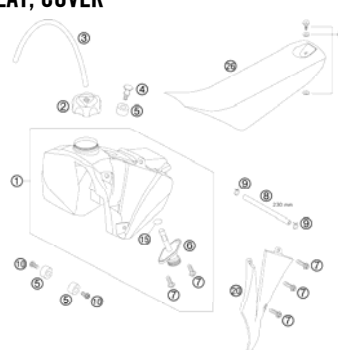
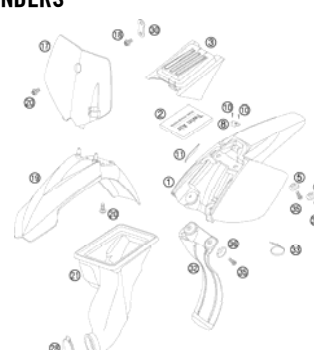

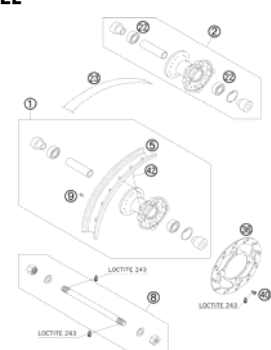
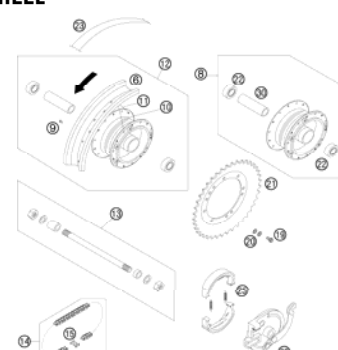
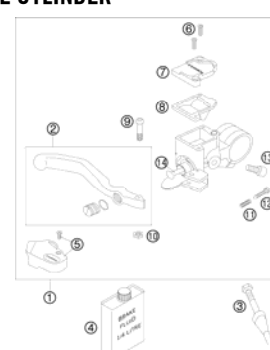
<p>FRONT FORK, TRIPLE CLAMP</p>  <p>3</p>	<p>HANDLEBAR, CONTROLS</p>  <p>5</p>	<p>FRAME, SIDE STAND</p>  <p>6</p>	<p>MONOSHOCK DISASSEMBLED</p>  <p>7</p>
<p>SWINGARM, MONOSHOCK</p>  <p>8</p>	<p>EXHAUST SYSTEM</p>  <p>9</p>	<p>TANK, SEAT, COVER</p>  <p>10</p>	<p>MASK, FENDERS</p>  <p>11</p>
<p>DECAL</p>  <p>12</p>	<p>FRONT WHEEL</p>  <p>13</p>	<p>REAR WHEEL</p>  <p>14</p>	<p>HAND BRAKE CYLINDER</p>  <p>15</p>

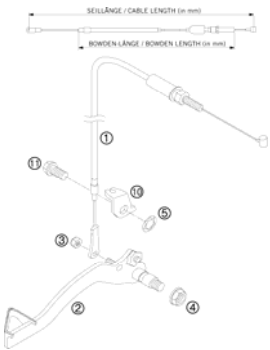
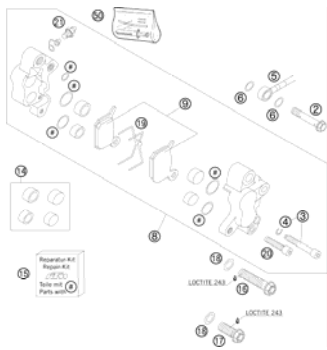
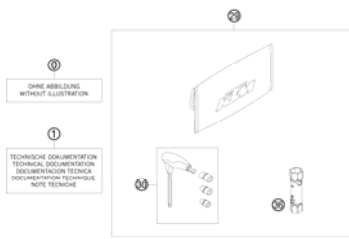
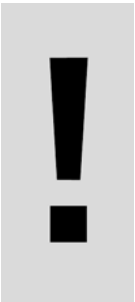
<p>REAR BRAKE CONTROL</p>  <p style="text-align: right;">16</p>	<p>BRAKE CALIPER FRONT</p>  <p style="text-align: right;">17</p>	<p>ACCESSORIES KIT</p>  <p style="text-align: right;">18</p>	
	<div style="display: flex; align-items: center;">  <p>All information contained is without obligation. KTM-Sportmotorcycle AG particularly reserves the right to modify any equipment, technical specifications, prices, colors, shapes, materials, services, service work, constructions, equipment and the like so as to adapt them to local conditions or to cancel any of the above items, all without previous announcement and without giving reasons. KTM may stop manufacturing certain models without previous notice. KTM shall not be held liable for any deviations of availability and/or ability to deliver, illustrations, descriptions, printing and/or other errors. The illustrated models partly contain extra equipment, which is not applied to standard models. © by KTM-SPORTMOTORCYCLE AG, Mattighofen AUSTRIA; All rights reserved; Reprint, also in extracts, with written allowance of KTM-SPORTMOTORCYCLE AG, Mattighofen only.</p> </div>		

FRONT FORK, TRIPLE CLAMP

50 SX JUNIOR USA 2008

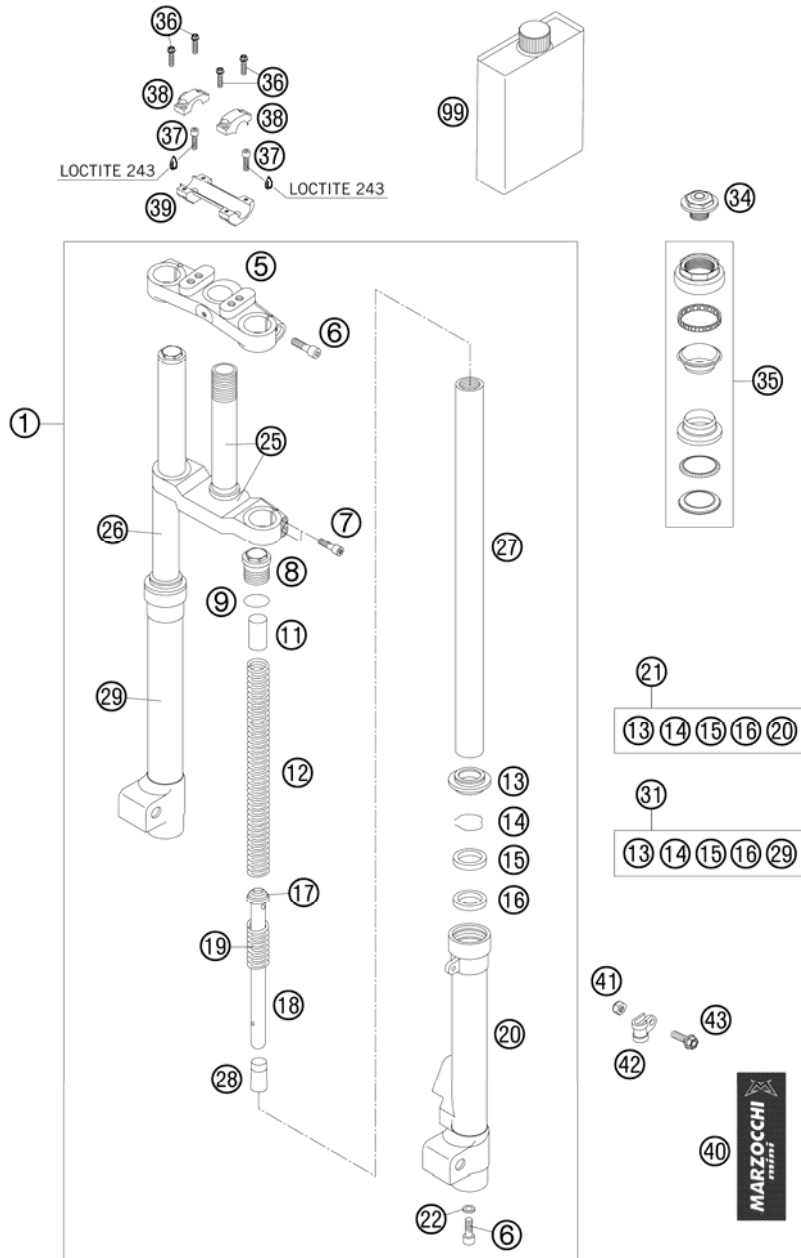

FIG	PART NUMBER	DESCRIPTION	QTY
1	45101000444	FORK CPL. SX JUN MARZ. 2002	1
5	7501476A	TOP FORK PLATE	1
6	0912080303	AH SCREW DIN0912-M 8X30	4
7	0912060253	AH SCREW DIN0912-M 6X25	4
8	7504212AC	PLUG CAP	2
9	7528010	O-RING	2
11	7518031	PRE LOAD BUSH L=55MM 2002	2
12	75141169	SPRING 2N/MM	2
12	75141214	SPRING 2,5N/MM	x
13	7533297	DUST SEAL	2
14	7523264	STOP RING	2
15	7528230	OIL SEAL 32/42/6,5-9,5	2
16	7522166AA	WASHER D42X32,5X1,5	2
17	7524157	PISTON RING D32	1
18	7803936/A	ONLY FOR REBOUND DAMPING PISTON ROD REBOUND JUNIOR 02	1
18	7803938/A	REBOUND DAMPING - LEFT SIDE PISTON ROD COMPRESSION JUN. 02	1
19	75141015	COMPRESSION DAMP.- RIGHT SIDE REBOUND SPRING	2
20	75031570A	SLIDER L/S 50 LC 2002	1
21	75031570A/R	SLIDER CPL. L/S 50LC 2002	1
22	7522225	WASHER 14X8X1,5	2
25	77051124	BOT. FORK PLATE CPL. MINI/JUN	1
26	7708247/R	FORK TUBE R/S MINI/JUN. 02	1
27	7708248/R	FORK TUBE L/S MINI/JUN. 02	1
28	7512068	FOOT BUFFER	2
29	75031571A	SLIDER R/S 50 LC 2002	1
31	75031571A/R	SLIDER CPL. R/S 50LC 2002	1
34	45101036000	STEER.HEAD SCREW M20X1,5 SW 27	1
35	45101081200	STEER.STEM B. CPL. 50 SXR 2006	1
36	0025080306	HH COLLAR SCREW M8X30 TX40	4
37	0912100250	AH SCREW DIN6912-M10X25,10.9,L	2
38	50301038000	HANDLEBAR CLAMP D=22MM 2001	2
39	45101039000	HANDLEBAR SUPPORT D=22MM 2001	1
40	7547325	STICKER LEFT SIDE MARZOCCHI	1

084500110 / C084510110

* NEW PART

X AS REQUIRED

FRONT FORK, TRIPLE CLAMP

50 SX JUNIOR USA 2008

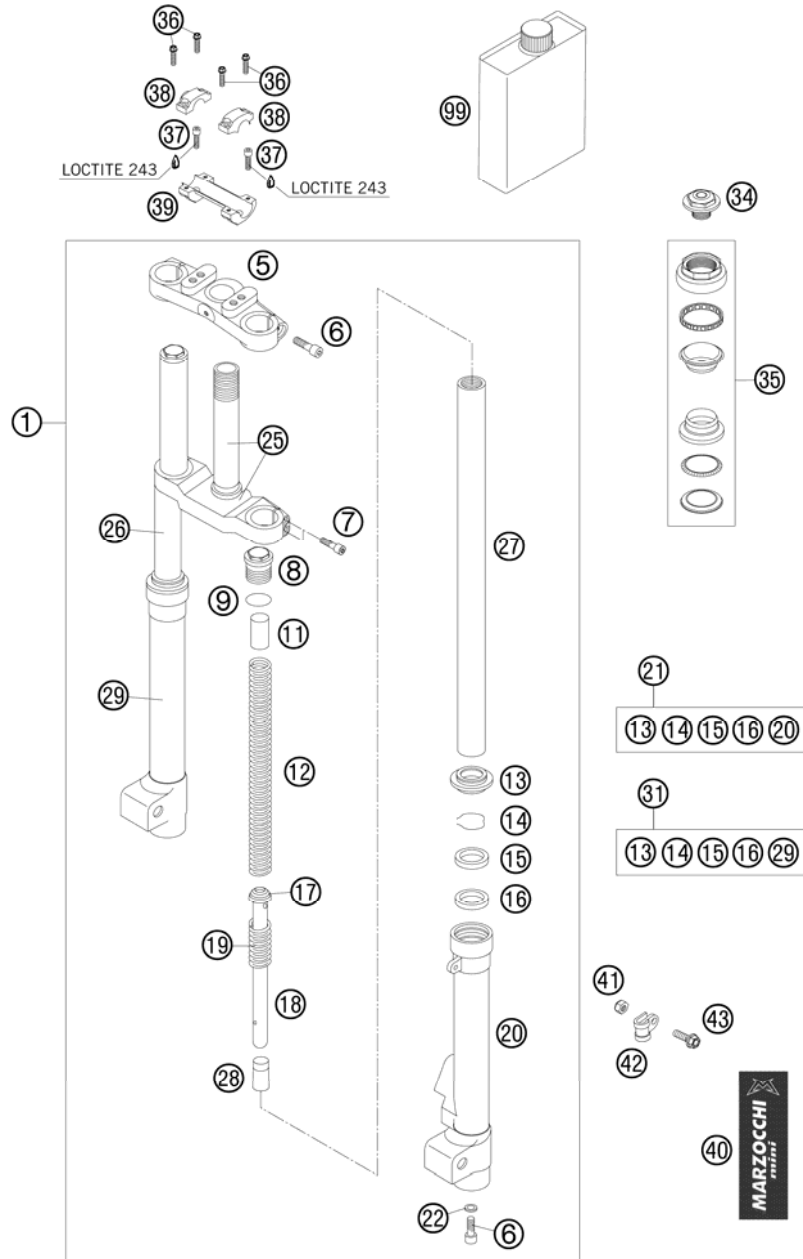

FIG	PART NUMBER	DESCRIPTION	QTY
40	7547331	STICKER RIGHT SIDE MARZOCCHI	1
41	0985050003	SELF LOCKING NUT DIN0985-M 5	1
42	45001070000	BRAKE CABLE CLAMP RSGU 9/12	1
43	0025050206	HH COLLAR SCREW M5X20 TX30	1
99	7550013	FORKOIL EBH16 SAE 7.5	1

084500110 / C084510110

* NEW PART

X AS REQUIRED

HANDLEBAR, CONTROLS

50 SX JUNIOR USA 2008

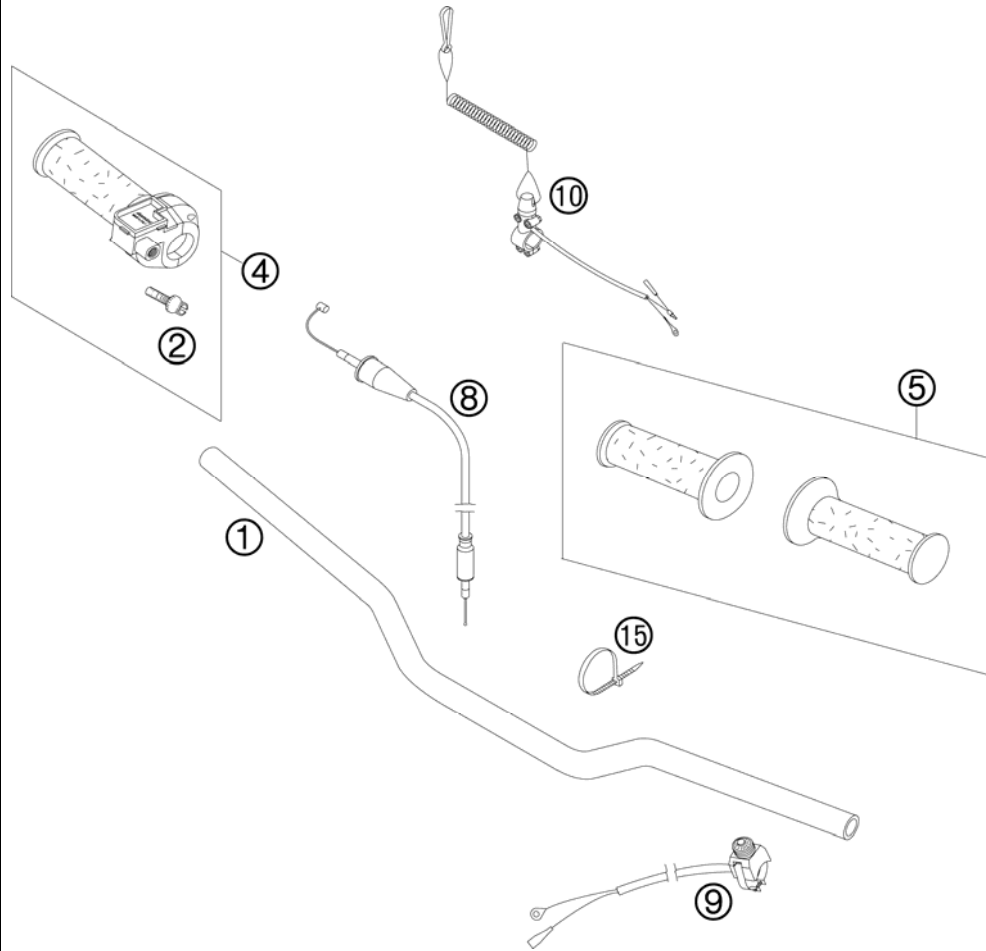

FIG	PART NUMBER	DESCRIPTION	QTY
1	45102001000	HANDLEBAR 50 AC+LC 2005	1
2	45002010050	ADJUSTING SCREW	1
4	45002010000	TWIST GRIP CPL. 50 SXR	1
5	45002021000	GRIPP SET	1
8	45102091100	THROTTLE CABLE JUN.762/644 02	1
9	50311089200	SHORT CIRCUIT BUTTON 02	1
10	45011089044	S.CIRCUIT BUTTON W. RIP CORD	x
15	44011076100	CABLE TIE 100/2,5MM BLACK	x
15	44011076200	CABLE TIE 200/3,6MM BLACK	x

084510211 / C084510211

* NEW PART

X AS REQUIRED

FRAME, SIDE STAND

50 SX JUNIOR USA 2008

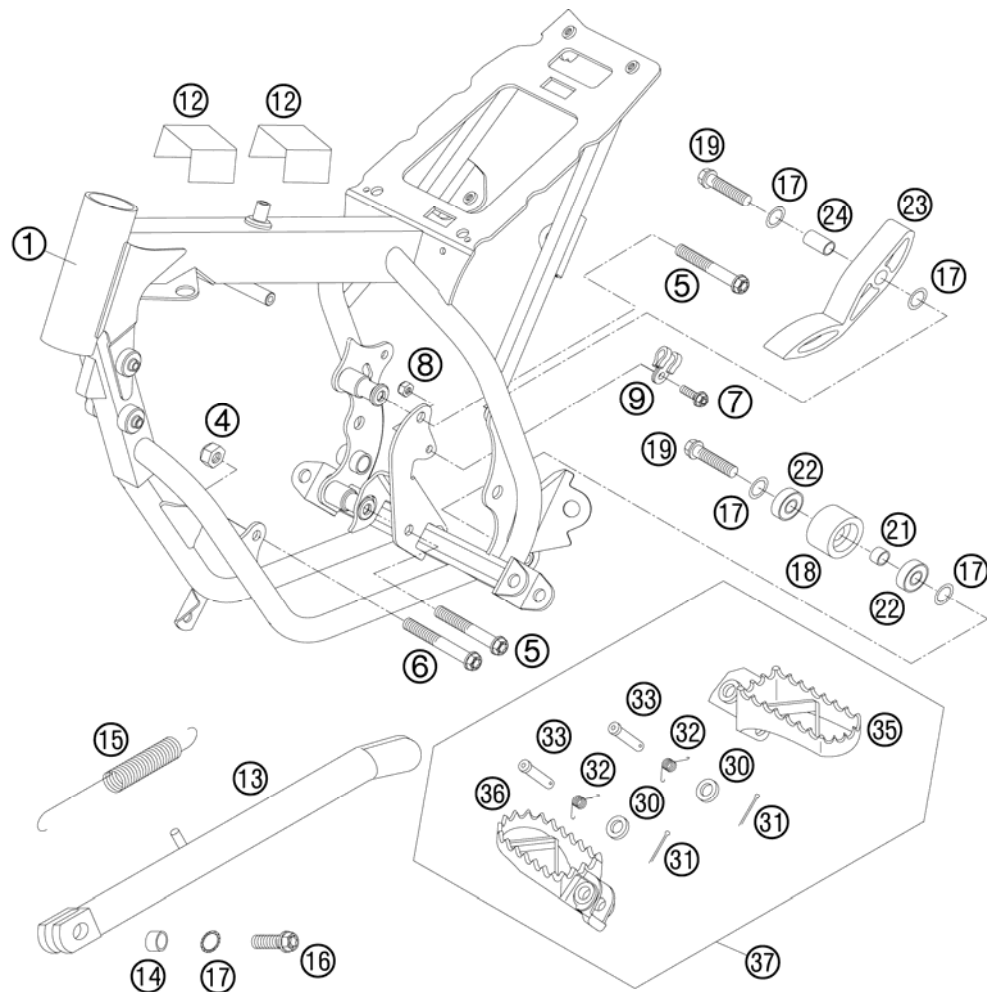

FIG	PART NUMBER	DESCRIPTION	QTY
1	4510300100030	FRAME PRO JUNIOR LC "ME2R" 07	1
4	54310086200	SELF LOCKING NUT M8 10.9	1
5	0025080606	HH COLLAR SCREW M8x60 TX40	2
6	0025080656	HH COLLAR SCREW M8X65 TX40	1
7	0025050126	HH COLLAR SCREW M5x12 TX30	1
8	0985050003	SELF LOCKING NUT DIN0985-M 5	1
9	45001070000	BRAKE CABLE CLAMP RSGU 9/12	1
12	58711054050	METAMOLL FOR BATTERY BRACKET	2
13	4510302320090	SIDE STAND L=285MM SILVER 02	1
14	45103023250	BUSHING FOR SIDE STAND 02	1
15	51003021000	SIDESTAND SPRING LONG	1
16	0025080206	HH COLLAR SCREW M8X20 TX40	1
17	36003014000	LOCK WASHER 8MM	5
18	50203053000	CHAIN ROLL D=30MM	1
19	0025080306	HH COLLAR SCREW M8X30 TX40	2
21	74003021000	BUSHING 8.2 X 12 X 6	1
22	0625006087	GROOVED BALL BEAR. 608 2RS C3	2
23	51103053000	CHAIN SLIDING PIECE BELOW '97	1
24	51103053051	BUSHING 8,2X10X20	1
30	0125100003	WASHER DIN0125-A10,5	2
31	0094032253	PIN DIN0094-3,2X25 STEEL	2
32	54603041000	FOOTREST SPRING L/S & R/S	2
33	54803044000	BOLT FOR FOOT PED 03	2
35	5460304000090	FOOT REST L/S SILVER	1
36	5460314000090	FOOT REST R/S SILVER '98	1
37	4510304013390A	FOOTREST L.+R. CPL. MINI 03	1

084510311 / C084510311

* NEW PART

X AS REQUIRED

MONOSHOCK DISASSEMBLED

50 SX JUNIOR USA 2008

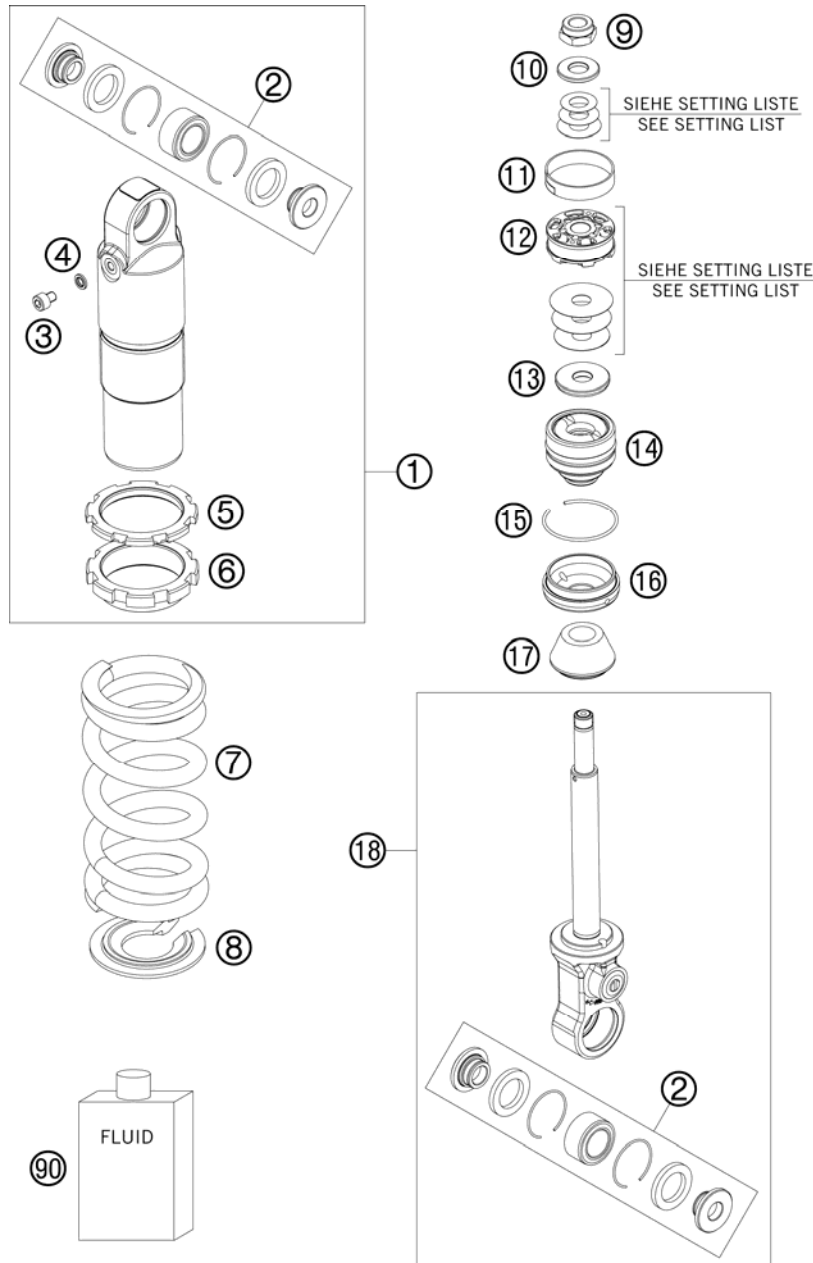

FIG	PART NUMBER	DESCRIPTION	QTY
1	36120784S	MONOSHOCK TOP PART L140 CPL.07	1
2	R306	REPAIR KIT BEARINGS 50SX JUN07	2
3	36120785	SCREW M5 C.K. RVS	1
4	36120782	SEAL D5,21XD8,38X1,22	1
5	36120015	COUNTERNUT	1
6	36120418	ADJUSTING NUT	1
7	93010178S	SPRING 75N/MM 75-130 130MM OR.	x
7	93010179S	SPRING 65N/MM 65-130 130MM OR.	x
7	93010180S	SPRING 85N/MM 85-130 130MM OR.	x
8	36120461	SPRING RETAINER D=39	1
9	36120052	* PISTON ROD NUT M10X1	1
10	36120604	SHIM D10XD22X2,5	1
11	36120040	PISTON RING 8X1X108,3	1
12	36120071	* PISTON 6+6XD5.5/3.5	1
13	14360065	REBOUND DISC H=4 D=28,5	1
14*	36120787S	ADAPTOR 36MM H26,6 CPL. 07	1
15	40540015	CIRCLIP 38X1,5	1
16	36120780	RESERVOIR CAP D=36 H=9,5	1
17	36120427	BUMP RUBBER WP65 L=20	1
18	36120777S1	MONOSH. BOTTOM PART L86 CPL.07	1
90	50180342S1	SHOCK ABSORBER FLUID 5 LT '03	1

084510430 / C084510431

* NEW PART

X AS REQUIRED

SWINGARM, MONOSHOCK

50 SX JUNIOR USA 2008

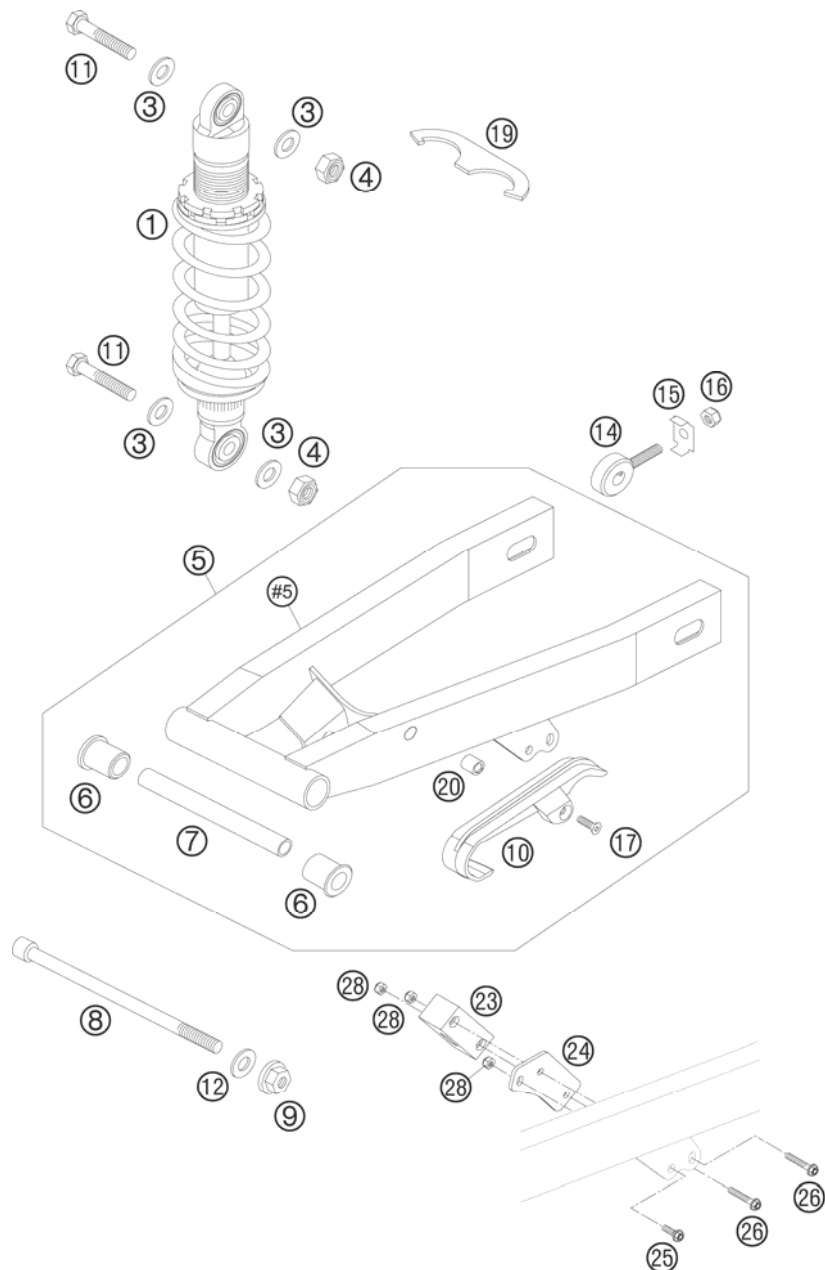

FIG	PART NUMBER	DESCRIPTION	QTY
1*	03189D01	MONOSHOCK 50 SX JUNIOR 08	1
3	0125100003	WASHER DIN0125-A10,5	4
4	0982100003	SELF LOCK.NUT DIN0982-M10 HIGH	2
5	45104030044	SWINGARM CPL. JUN. ADV.+LC 02	1
6	45004031000	BUSHING BOX L=30 MM	2
7	45004039000	SPACING TUBE 10X13X140 MM	1
8	45103014000	SWING ARM BOLT M10X158,5 02	1
9	49009082000	SELF LOCKING NUT M10 FK8	1
10	45104066000	CHAIN SLID. GUARD FRO. MINI 02	1
11	0931100453	HH SCREW DIN0931-M10X45	2
12	31004001100	WASHER 10,5 X 21 X 3	1
14	45010083000	CHAIN ADJUSTER	2
15	45010083060	SUPPORTING BRACKET	2
16	0985080003	SELF LOCKING NUT DIN0985-M 8	2
17	0991060203	FLAT H.SCREW DIN7991-M6X20 8.8	1
19	45004010090	HOOK WRENCH 50 SXR	1
20	55003139900	BLIND RIVET THREAD M6 STE. 4MM	1
23	45004070000	CHAIN GUIDE REAR	1
24	45104170000	BRACKET FOR CHAIN GUARD 02	1
25	0025050126	HH COLLAR SCREW M5x12 TX30	1
26	0025050306	HH COLLAR SCREW M5X30 TX30	2
28	0985050003	SELF LOCKING NUT DIN0985-M 5	3

084510490 / C084510490

* NEW PART

X AS REQUIRED

EXHAUST SYSTEM

50 SX JUNIOR USA 2008

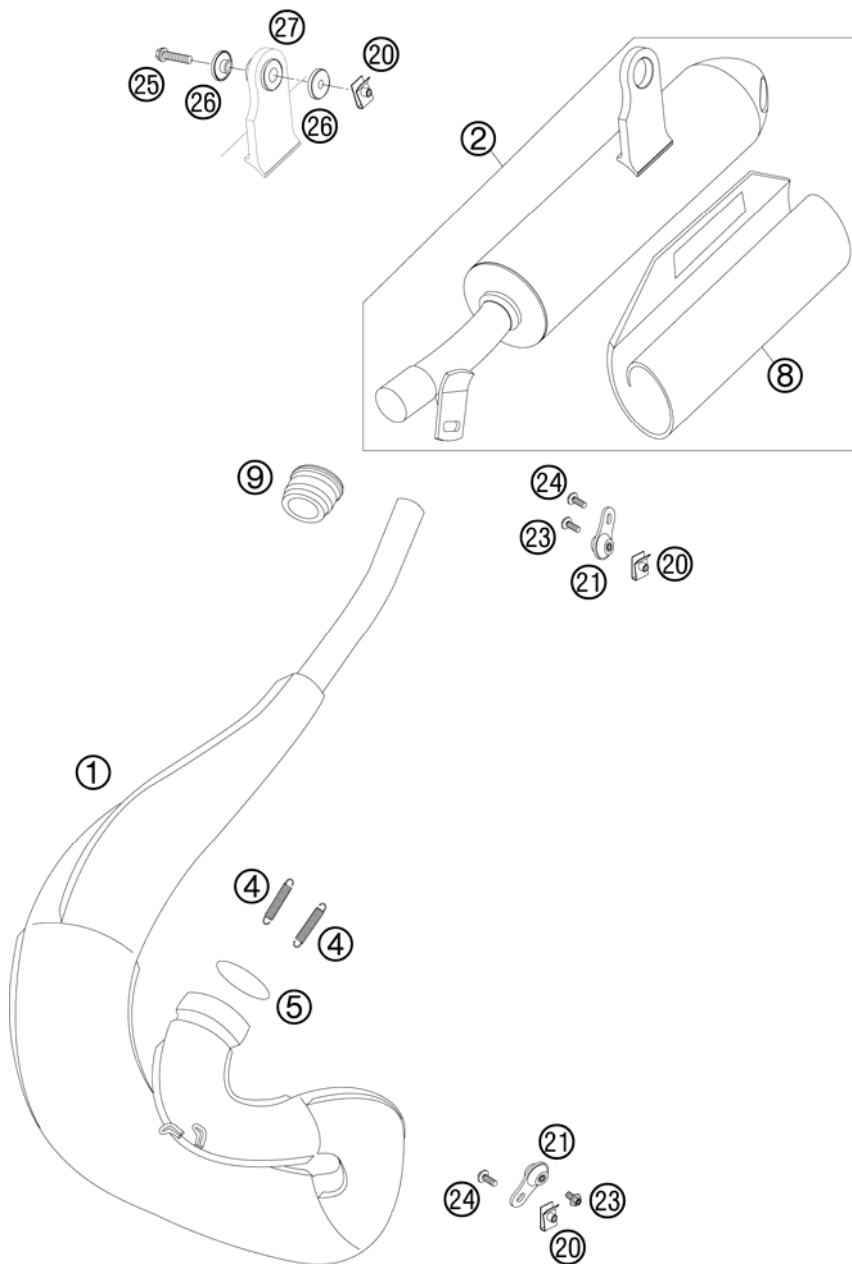

FIG	PART NUMBER	DESCRIPTION	QTY
1	45105007000	EXHAUST PIPE SX JUN/SEN 2001	1
2	45105079300	MAIN SILENCER 50 SX JUNIOR 06	1
4	50305016000	TEN.SPRING L=62MM EY.MOVEABLE	2
5	0770320030	O-RING 32,00X3,00 VITON	1
8	45105079056	ROCKWOOL PREFOMED 50 2002 110 GRAMM TOTAL WEIGHT	1
9	45105057000	EXHAUST RUBBER MINI 2002	1
20	54603048100	RANGE CHANGE METAL NUT M6	3
21	50305012000	SWINGELEMENT FOR EXHAUST PIPE	2
23	0025060126	HH COLLAR SCREW M6X12 TX30	2
24	0024060156	HH COLLAR SCREW M6X15 TX30	2
25	0025060306	HH COLLAR SCREW M6X30 TX30	1
26	54605069000	BUSHING 7,5X12X28X7,8 '96	2
27	54605068000	EXHAUST BRACKET RUBBER BLACK	1

084510511 / C084510510

* NEW PART

X AS REQUIRED

TANK, SEAT, COVER

50 SX JUNIOR USA 2008

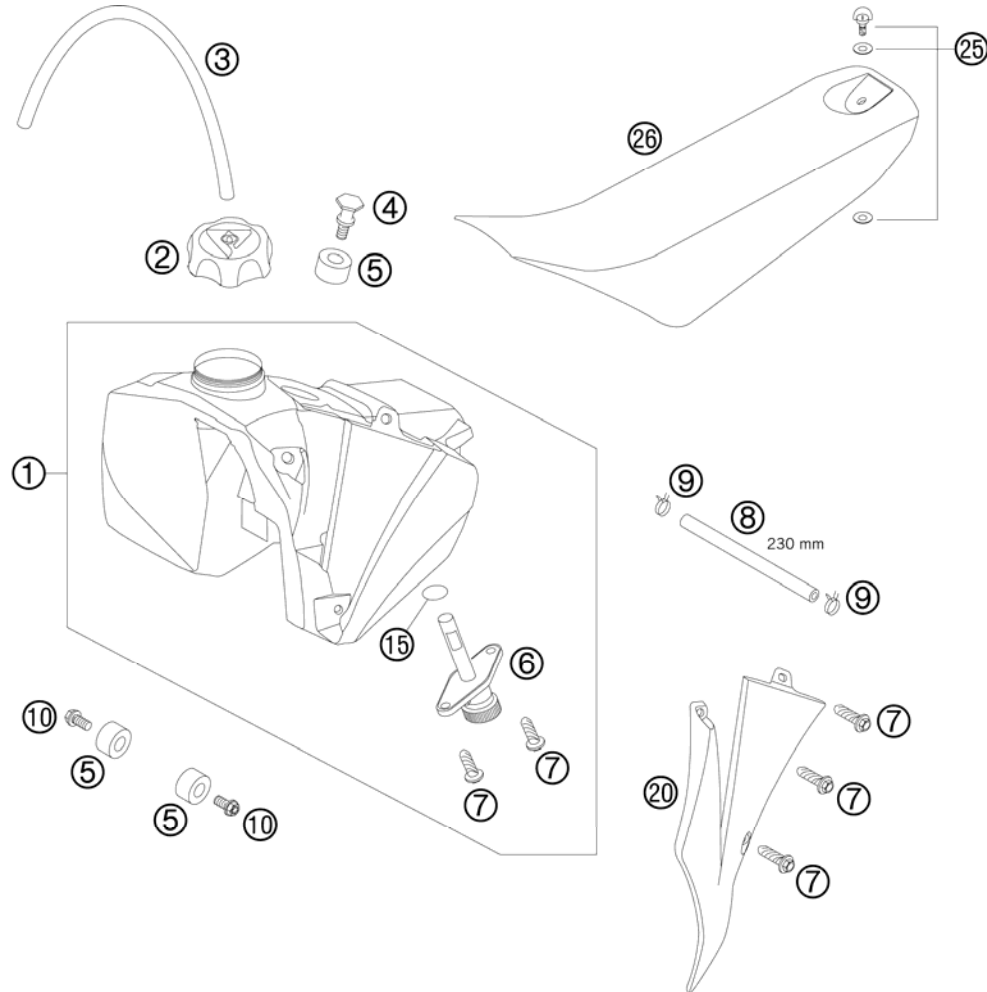

FIG	PART NUMBER	DESCRIPTION	QTY
1	4510701300030	FUEL TANK SX JUN/SEN "LC" 07	1
2	49007008044	FILLER CAP CPL. SMALL	1
3	31007107001	PVC-HOSE 6X9 MM PER METER	x
4	45107011000	TANK SCREW MINI 50 2001	1
5	50307014000	TANK ROLLER 12X26X12 '98	3
6	58507003000	FUEL COCK CPL. SMALL RALLYE'96	1
7	0017060203	EJOT PT SCREW K60X20 WS=6	8
8	58307016001	FUEL HOSE VITON 6X1,5 PER/M	x
9	45031005000	YDNAC-CLAMP FUEL HOSE (8MM)	2
10	0025060126	HH COLLAR SCREW M6X12 TX30	2
15	55007006200	O-RING 11X1,8 NBR 70	1
20	4510805000004	SPOILER LEFT SX JUN/SEN 2001	1
20	4510805100004	SPOILER RIGHT SX JUN/SEN 2001	1
25	45007040051	QUICK RELEASE CPL. 50 SXR '97	1
26	45107040500	SEAT 50 AC+LC 2005	1

084500710 / C084510710

* NEW PART

X AS REQUIRED

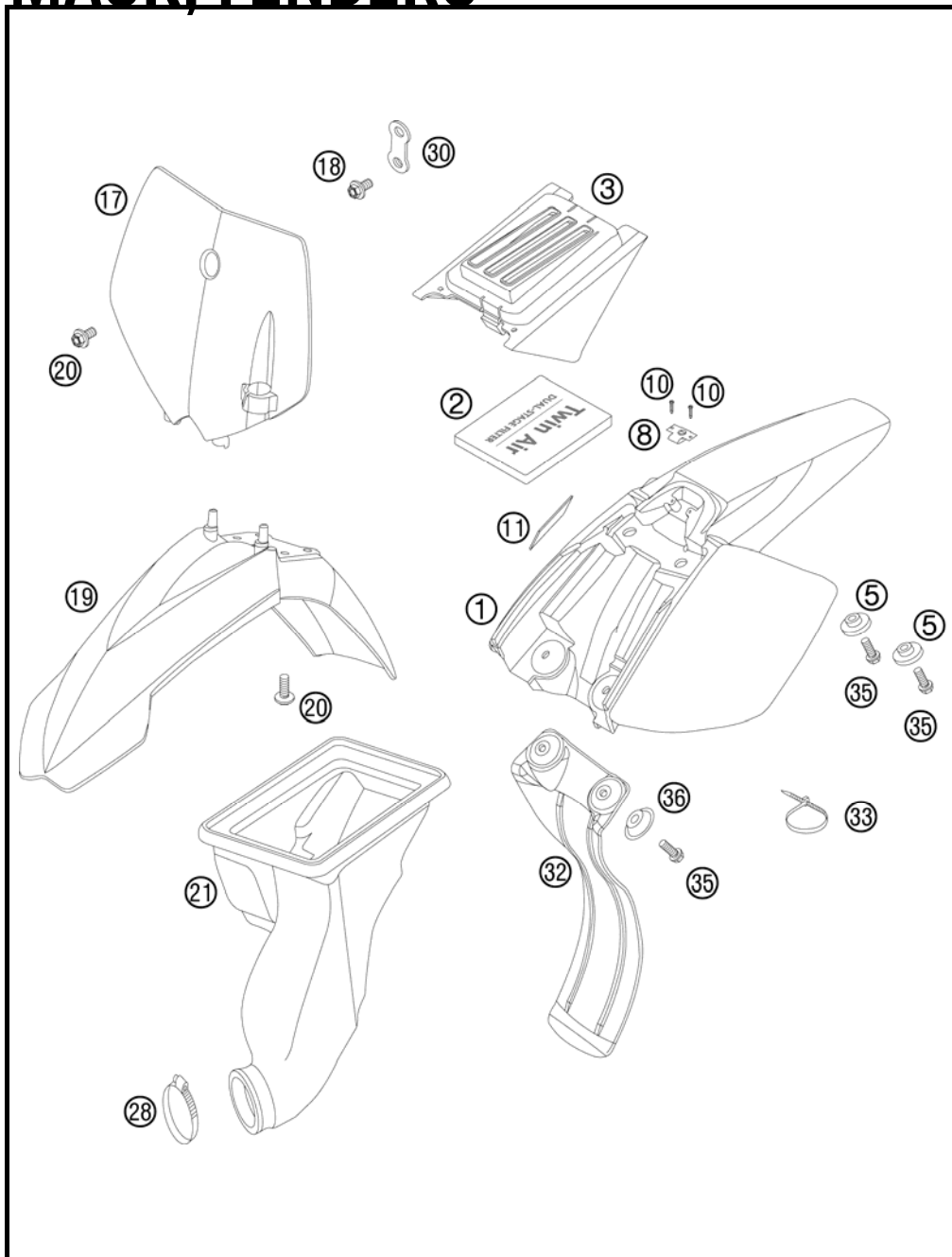

FIG	PART NUMBER	DESCRIPTION	QTY
1	4510801300004	REAR PART 50 MINI ORANGE 2003	1
2	45106015000	AIR FILTER 134X96X15MM 01	1
3	45106012000	FILTER COVER JUN/SEN 2001	1
5	45108013050	BUSH F.REAR P. SX JUN/SEN 2001	2
8	45007040050	QUICK RELEASE LATCHPLATE	1
10	0981350163	SHEET MET.SCR.DIN7981- 3,5X16	2
11	59003001099	METAMOLL 90X45X3MM 03	1
17	4510800700004	NUMBER PLATE SX JUN/SEN 2001	1
18	0025060106	HH COLLAR SCREW M6X10 TX30	1
19	4510801000004	FENDER FRONT SX JUN/SEN 2001	1
20	0024060106	HH COLLAR SCREW M6X10 TX30	5
21	45106026000	CARBUR.CONNEC.BOOT SXR JUN. 02	1
28	54305058000	HOSE CLAMP 30-45 SGT	1
30	45108007050	BRACKET FOR NUMBER PLATE	1
32	45106010000	SPLASH PROTECTOR JUNIOR 2002	1
33	44011076305	CABLE TIE 300/4,8MM BLACK	2
35	0025060166	HH COLLAR SCREW M6X16 TX30	4
36	72210079000	BUCKET	2

084500811 / C084510810

* NEW PART

X AS REQUIRED

FIG	PART NUMBER	DESCRIPTION	QTY
1*	45108399000	DECAL SET CPL. 50 SX JUN. 08	1

①

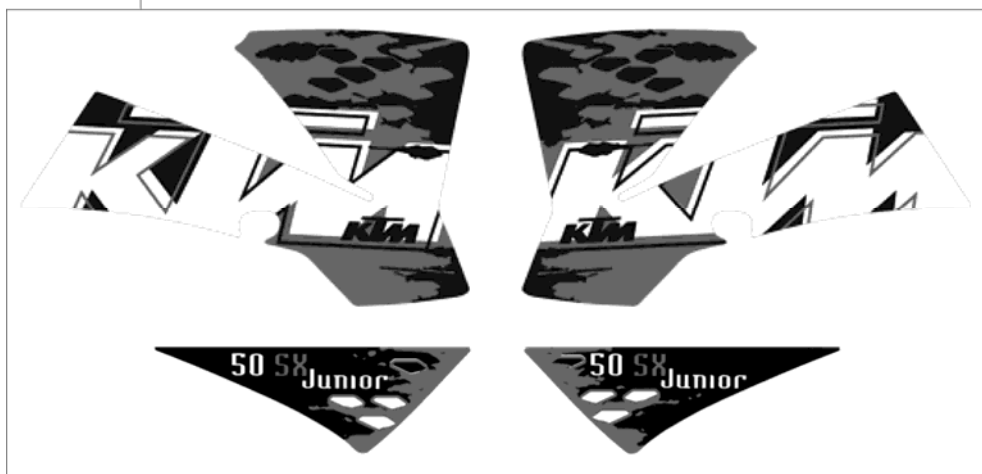

084510831 / C084510831

* NEW PART

X AS REQUIRED

FRONT WHEEL

50 SX JUNIOR USA 2008

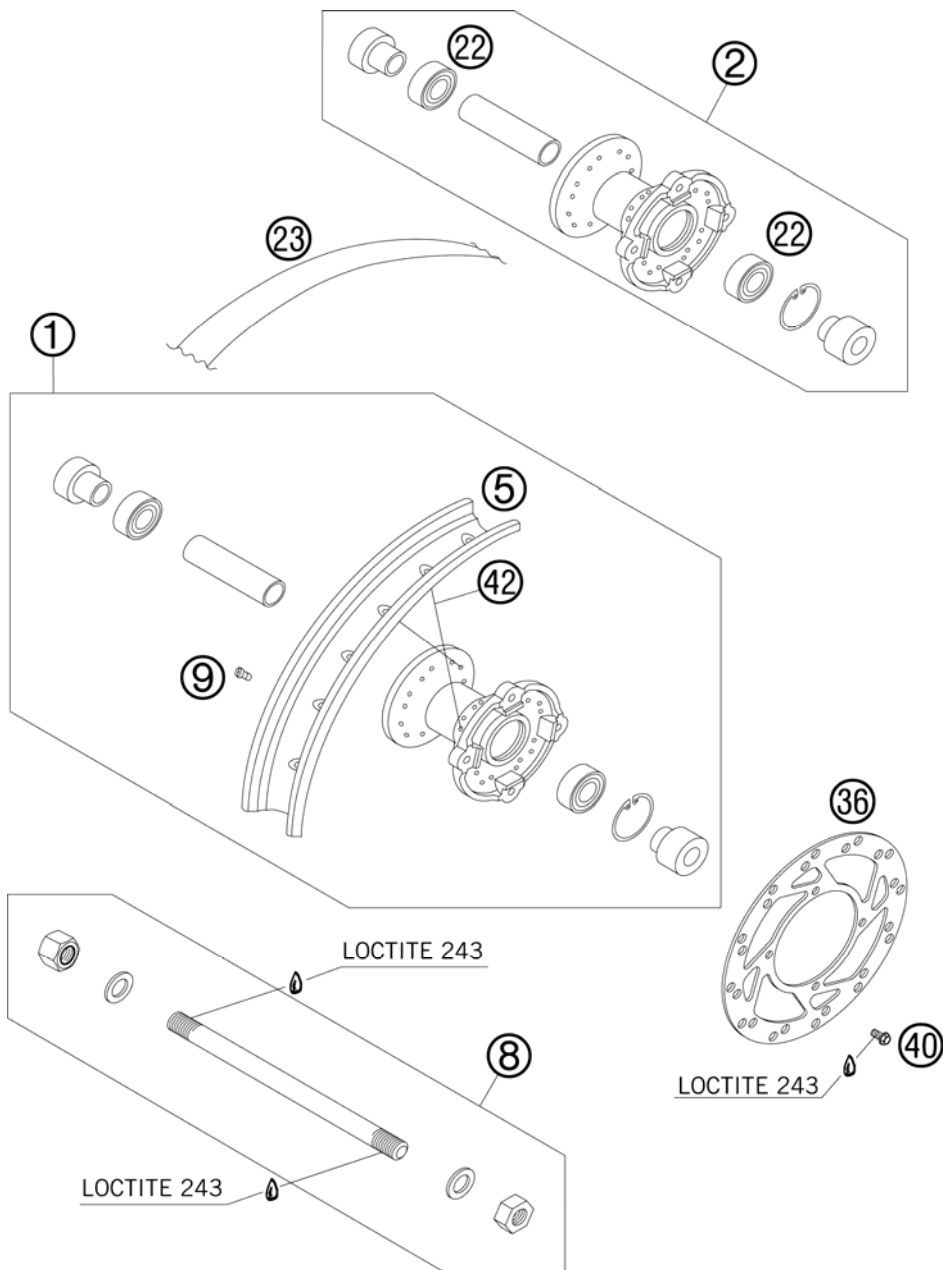

FIG	PART NUMBER	DESCRIPTION	QTY
1	45109001444	FRONT WHEEL CPL.1,5X10"STEEL	1
2	45109010044	FRONT WHEEL HUB CPL. 2002	1
5	45109001101	RIM 1,6X10" ALUMINIUM 2007	1
8	46010085044	AXLE CPL. 207MM M12X1	1
9	45109072000	SPOKE NIPPLE 3MM	28
22	0625062027	BALL BEARING 6202 2RS1 C3	2
23	45009073000	RIM BAND 10" 22MM	1
36	45109060000	BRAKE DISC FRONT JUN/SEN 02	1
40	59009062013	SPECIAL SCREW M6X13 WS=8 10.9	4
42	45109071102	SPOKE 3X100X6MM-110°	28

084500913 / C084510910

* NEW PART

X AS REQUIRED

REAR WHEEL

50 SX JUNIOR USA 2008

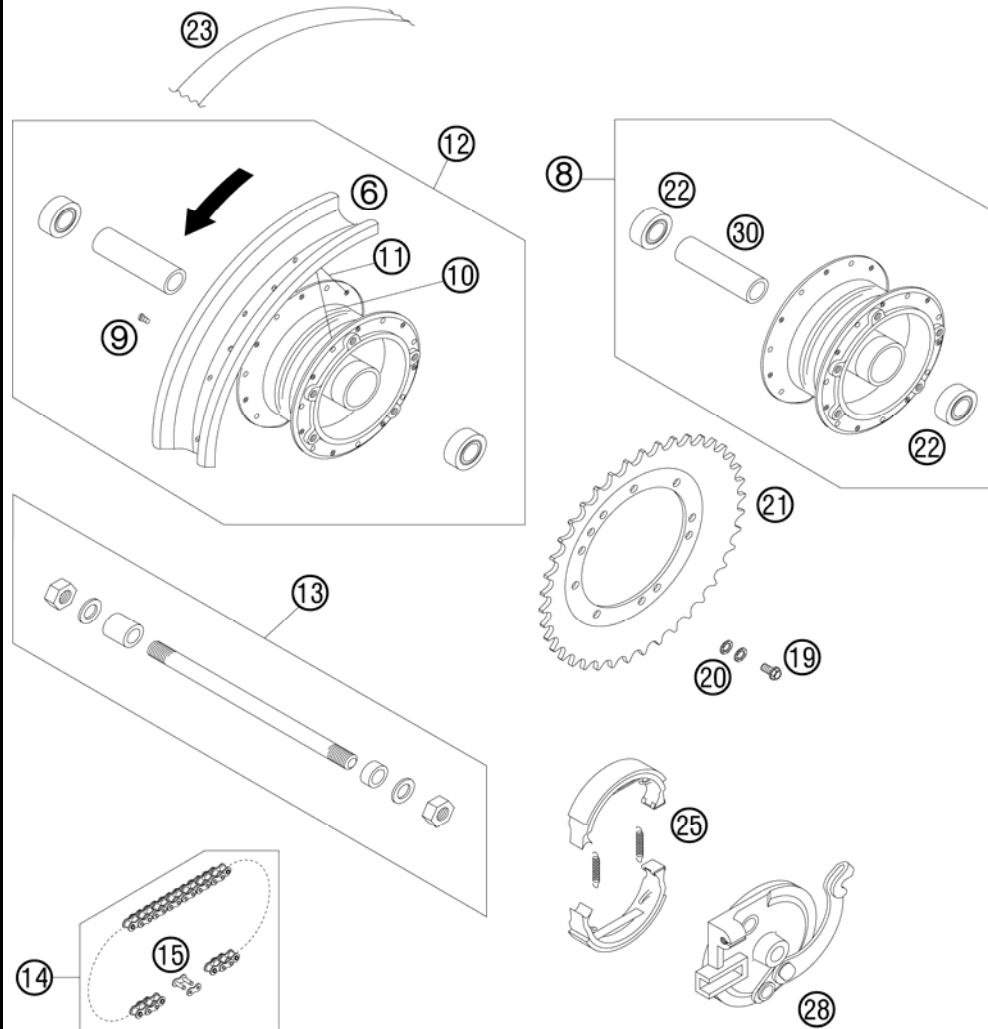

FIG	PART NUMBER	DESCRIPTION	QTY
6	45110070300	RIM REAR 1,6X10" ALU 2007	1
8	45110010244	REAR WHEEL HUB CPL. 2004	1
9	45109072100	SPOKE NIPPLE M 3,97	28
10	45110171072	SPOKE M3,97X72X115° 04	14
11	45110071072	SPOKE M3,97X72X70° 04	14
12	45110001644	REAR WHEEL-SP CPL.1,60X10" ALU	1
13	45010081000	AXLE REAR CPL. L=210MM	1
14	45110265104	CHAIN 1/2X3/16" 104 ROLLS	1
15	45110266000	CONNECTING LINK 1/2X3/16" 90RS	1
19	0025060166	HH COLLAR SCREW M6X16 TX30	5
20	50233041000	PAIR OF WASHERS M 6 NORDLOCK	5
21	45010051044	SPROCKET 44-T	x
21	45010051045	SPROCKET 45-T	x
21	45010051046	SPROCKET 46-T	x
21	45010051048	SPROCKET 48-T	1
22	0625060016	GROOV.BALL BEAR. G001.2RSR C3	2
23	45009073000	RIM BAND 10" 22MM	1
25	45009035000	BRAKE SHOES GARN.	1
28	45010030000	SUPPORTING PLATE CPL. REAR	1
30	45010011000	DISTANCE TUBE REAR	1

084501012 / C084511010

* NEW PART

X AS REQUIRED

HAND BRAKE CYLINDER

50 SX JUNIOR USA 2008

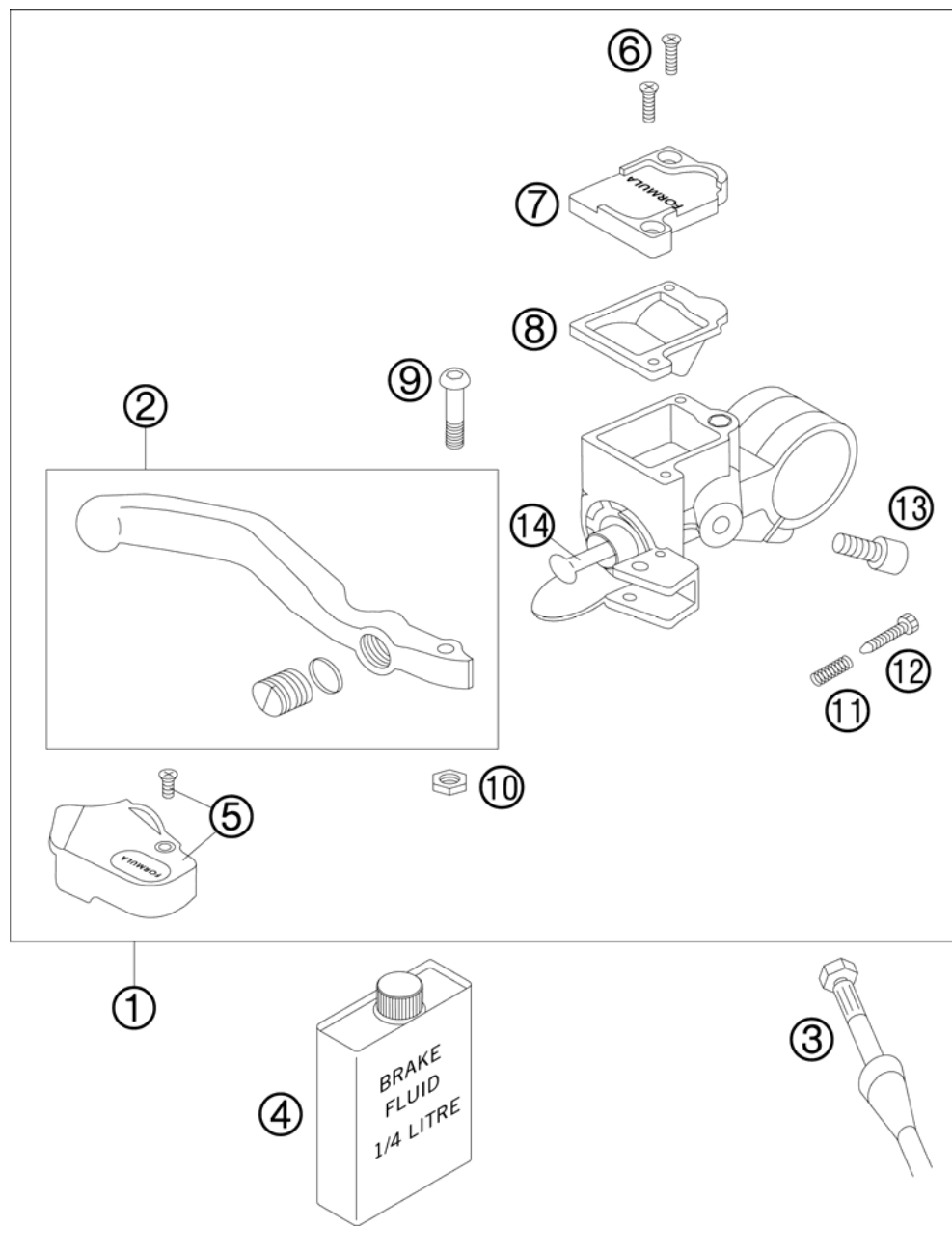

FIG	PART NUMBER	DESCRIPTION	QTY
1	45113101044	HAND BRAKE CYLIND.CPL.50 LC 02	1
2	45113002000	HANDBRAKE LEVER CPL. R/S 02	1
3	45113012000	BRAKE HOSE FR. SX JUN. LC 2002	1
4	00062030000	BRAKE FLUID DOT5.1 0,25L	1
5	45113004000	PROT.CAP HAND BRAKE CYL. 50 LC	1
6	0966030083	OVAL HEAD SCREW DIN0966-M 3X8	2
7	45113003000	HAND BRAKE CYLINDER COVER 04	1
8	45113009000	GASKET HAND BRAKE CYLINDER 04	1
9	45113006000	SPECIAL-AH SCREW M 5X18	1
10	45113013000	NUT M5 DIN 6334	1
11	45113021000	SPRING FOR HAND BRAKE LEVER 04	1
12	45113007000	ADJUSTING SCREW M 3X16 04	1
13	0912050103	AH SCREW DIN0912-M 5X10	1
14	45113008000	REP.KIT PISTON FRONT 50 04	1

084511310 / C084511310

* NEW PART

X AS REQUIRED

REAR BRAKE CONTROL

50 SX JUNIOR USA 2008

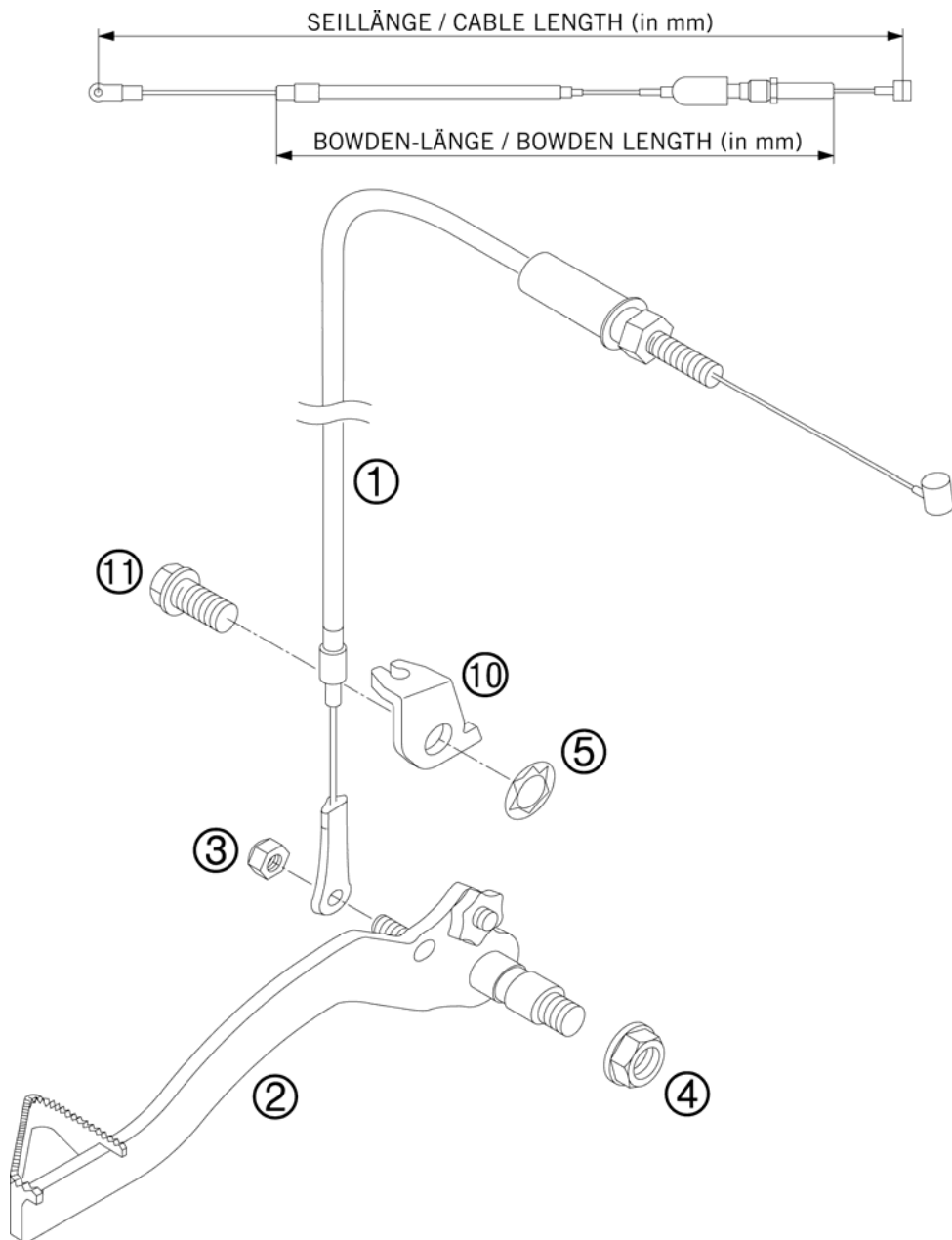

FIG	PART NUMBER	DESCRIPTION	QTY
1	45113070300	FOOT BRAKE CABLE REAR 720/570	1
2	45113050044	FOOT BRAKE LEVER CPL. 2001	1
3	0985050003	SELF LOCKING NUT DIN0985-M 5	1
4	54310086200	SELF LOCKING NUT M8 10.9	1
5	0797080003	TOOTHLOCK WASHER DIN6797-J 8,4	1
10	45113052000	BRAKE THRUST BEARING MINI 2001	1
11	0025080166	HH COLLAR SCREW M8X16 TX40	1

084511332 / C084511332

* NEW PART

X AS REQUIRED

BRAKE CALIPER FRONT

50 SX JUNIOR USA 2008

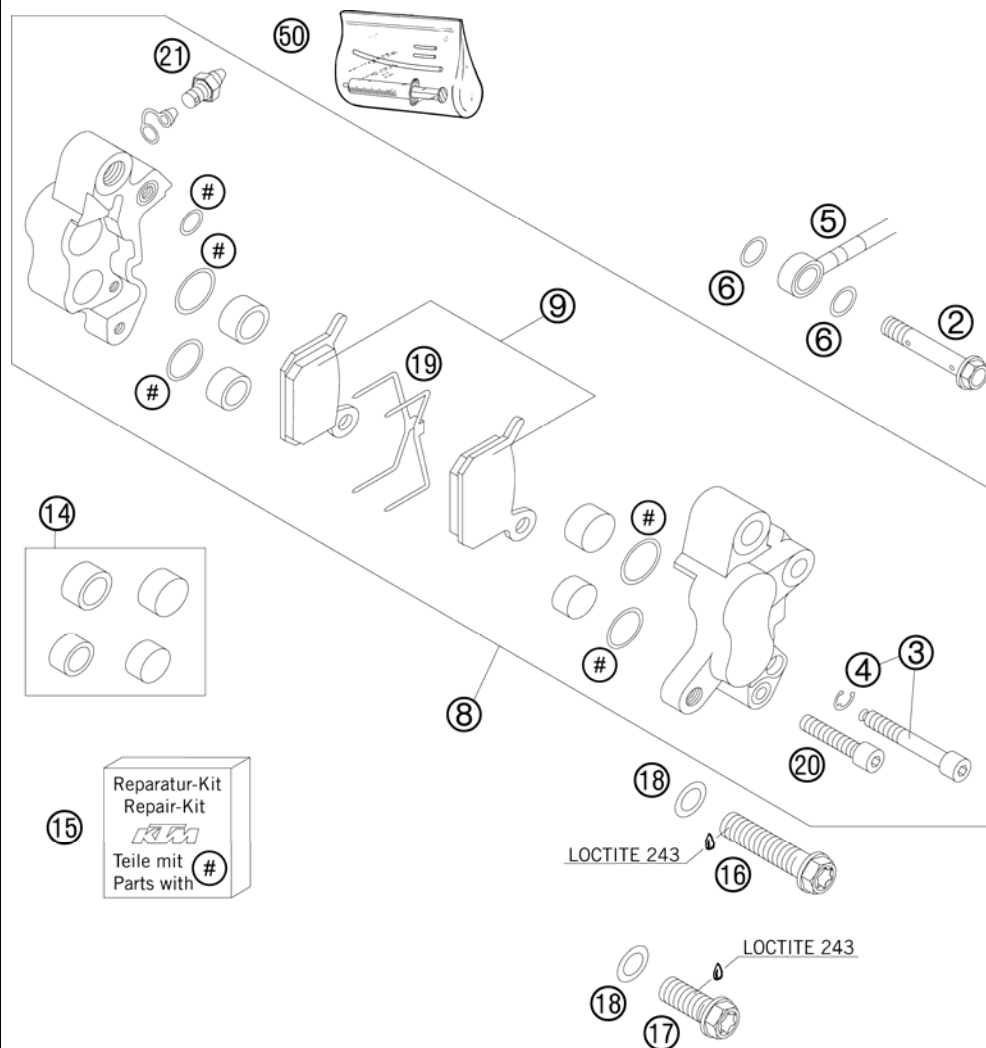

FIG	PART NUMBER	DESCRIPTION	QTY
2	45113025000	HOLLOW SCREW M6X34 50 LC 2002	1
3	45113125000	AH SCREW+CIRCLIP LC 50 02	1
4	0799025000	TAB WASHER DIN6799 RS2,5	1
5	45113012100	BRAKE HOSE FR. SX SEN. LC 2002	1
6	0770080019	O-RING 8,00X1,00 EPDM	2
8	45113015000	BRAKE CALIPER CPL.FR. 50 LC 02	1
9	45113030000	BRAKE PAD SET 50 LC 2002	1
14	45113019050	REPAIR KIT BRAKEPISTON	1
15	45113019000	REP.KIT SEAL RING 50LC 2002	1
16	0025080406	HH COLLAR SCREW M8X40 TX40	1
17	0025080256	HH COLLAR SCREW M8X25 TX40	1
18	0125080003	WASHER DIN0125-A 8,4	2
19	45113018000	RETAINING SPRING 50 LC	1
20	0912050203	AH SCREW DIN0912-M 5X20	1
21	45113020000	BREATHER SCREW 50 2002	1
50	45119050000	BLEEDER INJECTION-SET 50-65	x

084501363 / C084511364

* NEW PART

X AS REQUIRED

①
OHNE ABBILDUNG
WITHOUT ILLUSTRATION

①
TECHNISCHE DOKUMENTATION
TECHNICAL DOCUMENTATION
DOCUMENTACION TECNICA
DOCUMENTATION TECHNIQUE
NOTE TECNICHE

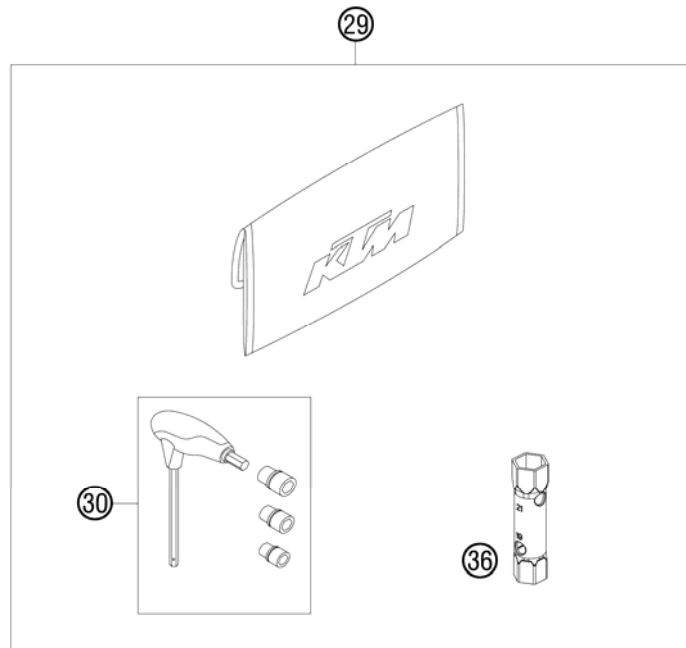
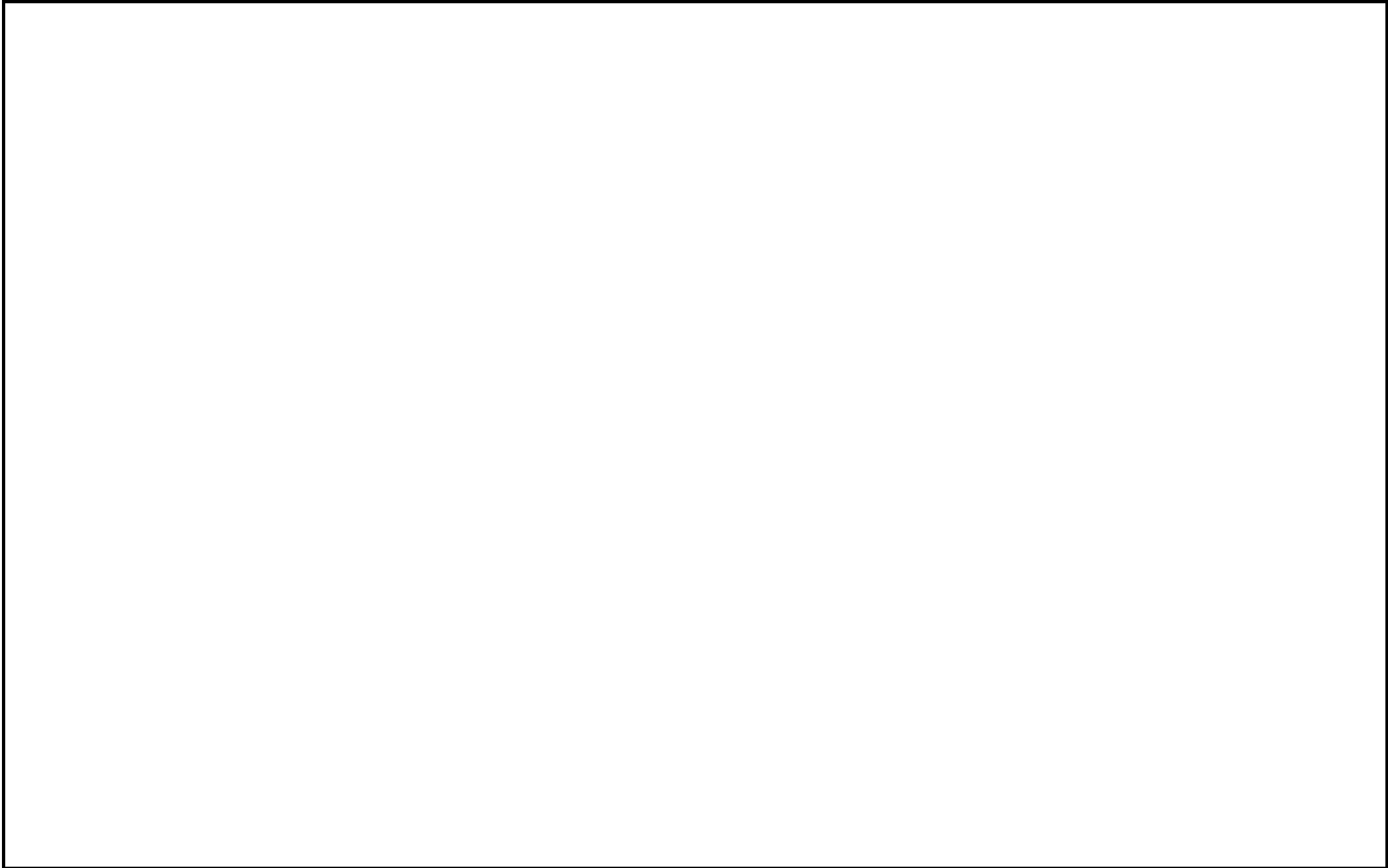

FIG	PART NUMBER	DESCRIPTION	QTY
0	312305	DOCUMENTS BAG 2006	1
0	312313	KTM BALLPOINT ORANGE	1
0	3210039	CUSTOMER WELCOME LETTER	1
0	45131023070	MAIN JET 70 DELLORTO	1
1	3211222	OWN.MAN. 50 SX JUN./50 SX 08	1
1	322000	SAFETY BROCHURES SPORTMINICYC.	1
1	3CF6001H3EN	SPM CHASSIS 50 SX JUNIOR 2008	1
1	3CM080245HEN	SPM ENGINE 50 SX JUNIOR 2008	1
29	45029099000	TOOL SET 50 MINI, 60/65 SX	1
30	60029070200	T-WRENCH WS=6/8/10 TX=45 B&F	1
36	45129072000	SPARK PLUG WRENCH	1

084512010 / C084512011

* NEW PART

X AS REQUIRED



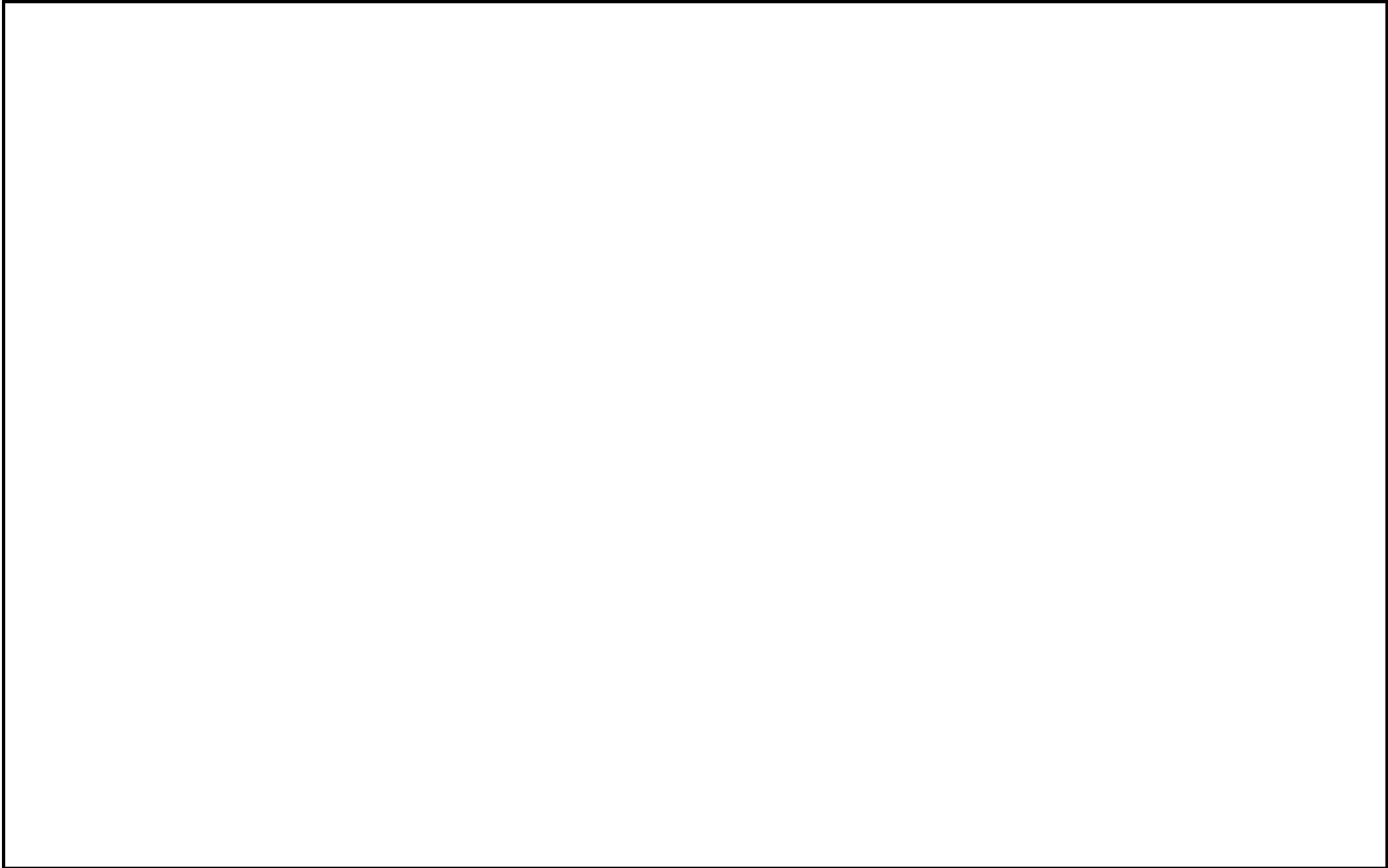



KTM-Sportmotorcycle AG
A-5230 Mattighofen
www.ktm.at

KTM Group Partner



3CF6001H3EN



Art.Nr.: 3CF6001H3EN 4/2007